

AM · FM · TELEVISION

BROADCAST

NEWS

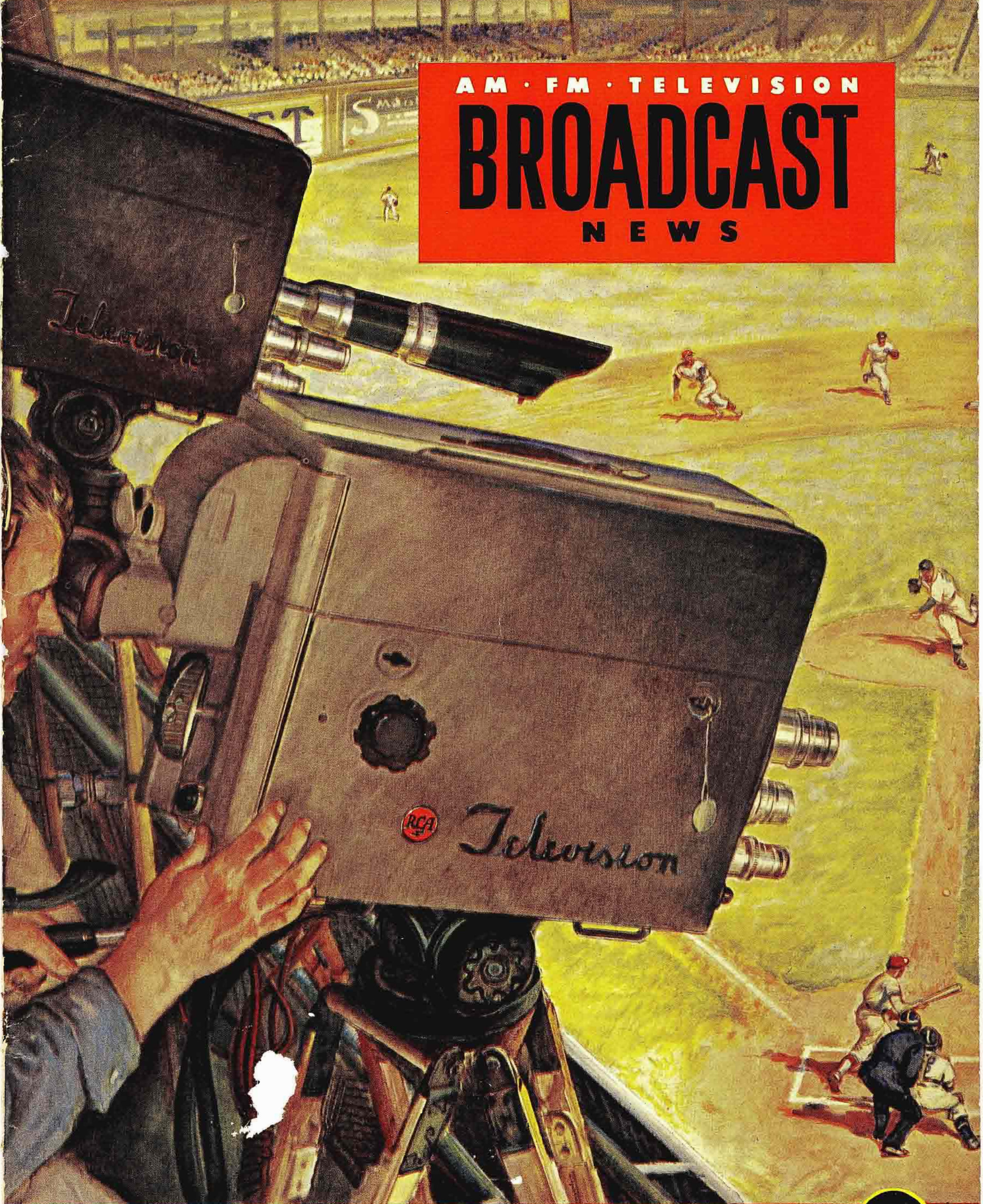

BASEBALL TELEVISION . . . See pg. 8





RCA-5671—The high-power triode with thoriated-tungsten filament

Now... 4-way economy for 50-kw AM transmitters

... with the new RCA-5671

1. FILAMENT POWER. The thoriated-tungsten filament of an RCA-5671 draws 60 per cent less power than a conventional pure-tungsten filament . . . making possible approximate savings of \$1300 a year* in filament power alone!

2. TUBE COST. The RCA-5671 now costs no more than the 9C22 which it replaces. The new price represents a saving of \$800 on a complement of four 5671's for a standard 50-kw transmitter.

3. CONVENIENCE. The RCA-5671 now employs an improved, lighter-weight radiator that reduces the weight of the tube by about 100 pounds . . . or approximately 43

*Based on the operation of four tubes for 6500 hours at 1 cent per kilowatt-hour.

per cent. The new radiator fits the same air jacket as used for the former radiator.

4. LIFE. RCA-5671's have been proved in actual operation. RCA-5671's are still going strong after more than 12,000 hours of actual broadcast service.

To get all the power-tube performance you pay for, buy RCA tubes. They're available from your local RCA Tube Distributor or direct from RCA. For technical information, write RCA, Commercial Engineering, Section 36IP, Harrison, New Jersey.

THE FOUNTAINHEAD OF MODERN TUBE DEVELOPMENT IS RCA.



RADIO CORPORATION of AMERICA

ELECTRON TUBES

HARRISON, N. J.

Broadcast News

AM • FM • TELEVISION

• • •

Published by the

RADIO CORPORATION OF AMERICA

ENGINEERING PRODUCTS DEPARTMENT . . . CAMDEN, NEW JERSEY

NUMBER 56

Subscription Rates

SEPTEMBER, 1949

In continental U. S. A. - \$4.00 for 12 issues

In other countries - - - \$5.00 for 12 issues

JOHN P. TAYLOR, Editor

JUDY J. ALESI, Ass't Editor

W. O. HADLOCK, M. L. GASKILL, E. B. MAY, Associate Editors

Contents

SUPERGAIN TV ANTENNA DEVELOPED BY RCA	4
BASEBALL TELEVISION by JOHN P. TAYLOR	8
WPIX BASEBALL	28
THE "NEW LOOK" AT KTBS	40
KTBS's NEW TRANSMITTER by W. M. WITTY	46
KAKE by HAROLD H. NEWBY	54
KOOS by ROGER L. SPAUGH	55
KSYC by JACK R. WAGNER	56
KXLL by PAT M. GOODOVER	57
KRDO by JOSEPH ROHRER	58
WHHM by WILLIAM MARSH	60
WSRS by BEN H. WHITTAKER	62
WISL by B. T. MARSHALL	64
WLAK by WILLIAM P. LEE	66
WBCK by A. J. GERANIS	68
WBAL-TV by WILLIAM C. BAREHAM	72

Copyright
Radio Corporation of America
RCA Victor Division
Camden, N. J.

PRINTED
IN
U. S. A.

OUR COVER for this issue is unusual, we think, and it came about in a rather unusual way. Ordinarily we start with a kodachrome transparency—either one made by our own Photographic Department, or one sent in to us by some helpful station engineer. This cover, however, started life as an oil painting by the well-known artist Charles DeFeo.

Mr. DeFeo painted it originally for use as a cover for NATION'S BUSINESS, published by the Chamber of Commerce of the United States—and it was in this form that it first came to our attention. Subsequently, through the courtesy of Mr. Lester Douglas, Director of Art and Printing for the Chamber of Commerce, we were able to borrow the original painting long enough to make our cover plates for this issue.

The thing we like about this cover—quite aside from its timeliness—is the very realistic reproduction of our TK-30A Cameras. When we first introduced the TK-30A Camera—less than three years ago—we deliberately set out on a promotion campaign which we hoped would result in the TK-30A becoming the symbol of TV broadcasting—just as the 44BX and 77D Microphones have become the symbol of AM broadcasting. The really wonderful performance of the TK-30A, its wide acceptance, and its almost universal use, have made such recognition almost inevitable. And now Mr. DeFeo—entirely without prompting, and even without our knowledge, has made it official. There's no doubt about it—the TK-30A is the symbol of TV today.

MOST OF THE CREDIT for the fine record of the TK-30A Camera and associated equipment is due to the design engineers in our so-called Television Terminal Equipment Section—and perhaps now is as good a time as any to bestow the orchids which this group deserves.

The Television Terminal Section (of our Broadcast Engineering Department) has designed all of the field, studio, and microwave TV gear which we have produced since the war. The list includes dozens of new equipment units, many of them (like the Sync Generator) extremely complicated.

As the result of many years experience in this business we are more or less resigned to the expectation that all new equipment units will have bugs in them—which will only show up in field use. And based on this experience we would have predicted (we did predict) an awful lot of bugs with all this new TV equipment going into production at once. We are pleased to report that we have seldom been so wrong. There have been bugs, of course, but not many and not bad ones. In fact, the way this equipment has operated is, to us, almost miraculous.

When you can take an equipment containing upwards of a thousand tubes (it takes about 600 minimum to get a signal on the air) and turn it over to a group of station engineers—who, although good AM men, have never operated TV equipment before—and then have it work consistently for them month after month . . . brother, that's good. And then if you can do that in more than fifty stations . . . brother, that's real good!

SMALLER STATIONS come into their own in the series of station articles starting on Page 54. In this series, describing some dozen 250 Watt and 1000 Watt stations, we have placed the emphasis on the choice and arrangement of equipment in stations of these powers. Probably no station installation is perfect—and no claim is made that those shown here are models of perfection. However, they are all good clean layouts and each has some interesting and noteworthy features of its own. Our hope is that station engineers planning new installations in these power categories will be able to pick up many good ideas from a study of "how the other fellow did it."

RCA Equipment in



WJZ-TV. RCA field equipment in action atop a WJZ-TV field truck. WJZ-TV also uses RCA television camera controls, microwave relay equipment, sync generators, studio cameras, video and audio control-room console, complete film facilities, turntables, microphones, Superturnstile antenna, and the 5-kw transmitter Type TT-5A.

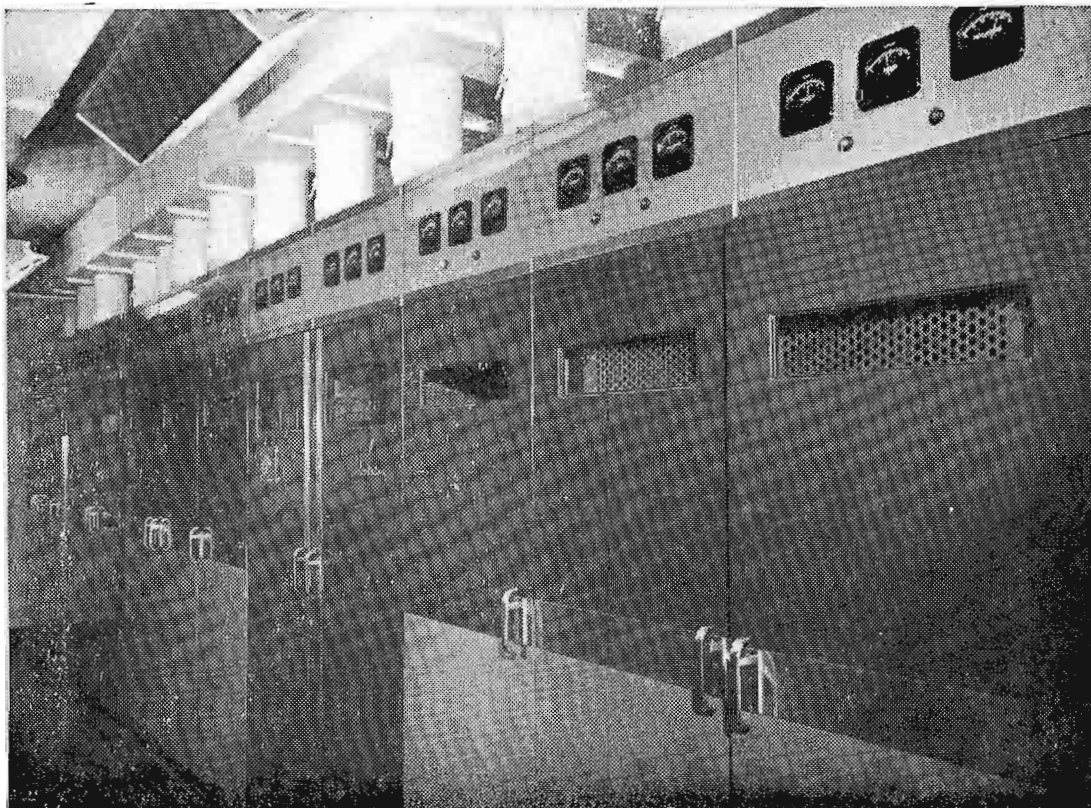

WENR-TV. The RCA 5-kw television transmitter Type TT-5A and RCA 10-kw FM transmitter Type BTF-10B at WENR-TV. This ABC station also includes an RCA Superturnstile antenna, field truck and field camera equipment, studio cameras, video and audio control-room equipment, film projectors, film cameras, turntables, and microphones.

ABC-TV Stations

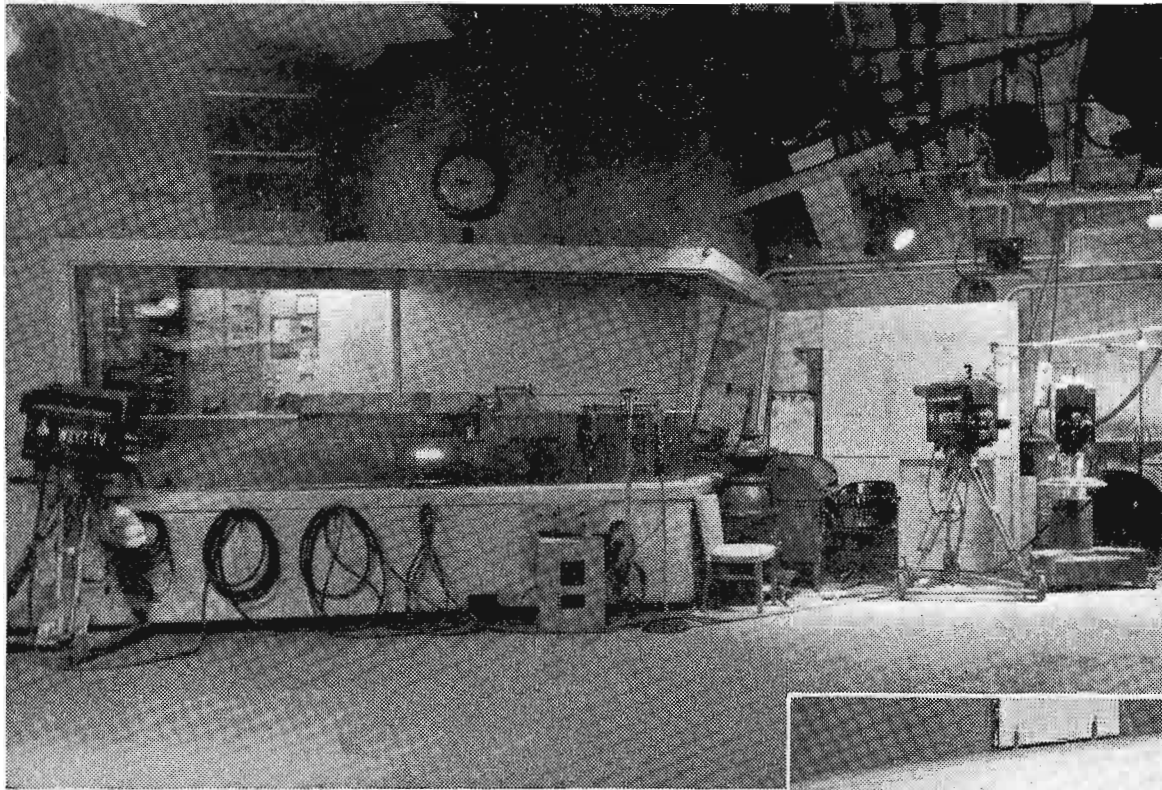

WXYZ-TV. One of the WXYZ-TV studios showing RCA studio cameras and the RCA-equipped control room. WXYZ-TV also uses RCA television field trucks, sync generator, microwave relay equipment, film projectors, slide projectors, film cameras, turntables, microphones, transmitter equipment—including the RCA TT-5A 5-kw transmitter and an RCA Superturnstile antenna.

KECA-TV. KECA-TV's television field truck—like all the other ABC-TV stations—is an RCA "studio on wheels." It is complete with RCA image orthicon cameras, camera tripods, camera control units, on-the-air master monitor, camera switching system, sync generator, microwave relay equipment, power supplies. KECA-TV also uses RCA studio cameras, film equipment, turntables, microphones, and an RCA Superturnstile antenna.

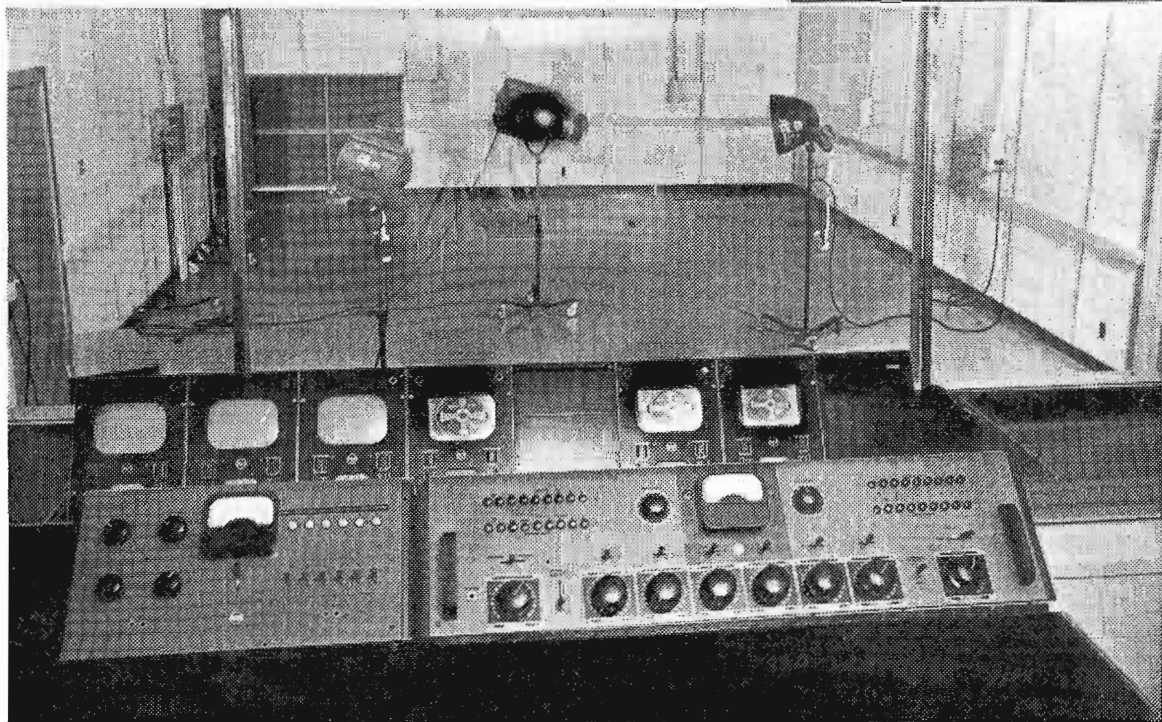

KGO-TV. Video control-room equipment at KGO-TV—as in all the other ABC-TV stations—is completely RCA. KGO-TV also uses RCA field cameras, microwave relay equipment, field truck, sync generator, studio cameras, film projectors, slide projectors, film cameras, turntables, microphones and an RCA Superturnstile antenna.



TELEVISION BROADCAST EQUIPMENT
RADIO CORPORATION of AMERICA
ENGINEERING PRODUCTS DEPARTMENT, CAMDEN, N.J.

In Canada: RCA VICTOR Company Limited, Montreal

"SUPERGAIN" TV ANTENNA DEVELOPED BY RCA

The development of a new type television transmitting antenna, known as the Supergain, opens many new possibilities to TV broadcasters in the way of higher values of gain and greater directivity. With this antenna, it may now be possible for a broadcaster to develop a radiation pattern to fit a metropolitan district and at the same time provide protection to adjacent and co-channel stations.

Developed by the RCA Engineering Products Department, the new television antenna will permit power gains in the order of 10 to 20. Actually, the number of elements can be chosen to obtain any reasonable value of gain. In addition to this, the antenna is capable of handling high input power and delivering output power with enormous ERP. The Supergain is sufficiently broadband to operate over any channel for which it is specifically designed.

The Supergain antenna consists fundamentally of dipoles mounted in front of reflecting screens having wave-length dimensions of one-half wide by five-eighths high placed on the sides of a tower. The screens connect electrically to the tower or to each other at their vertical edges. Sections of this antenna can be added to top sections of straight sided AM and FM towers of conventional design. For the heights required, the conventional type of tower is the most economical construction. This kind of construction can also be made

strong enough to support other antennas, such as Pylons for FM broadcasting and Superturnstiles for other TV stations.

There are many ways in which the dipoles can be connected to obtain directional patterns of different shapes in addition to the more frequently used omnidirectional. In order to prevent the mutual coupling of the dipoles with each other around the tower when connected in some of these different ways, dipole shielding wings have been designed which connect to the edges of the screens. These wings are rectangular in shape. They make an angle of 135° with the screen so as to effect a shield around the ends of the dipole. The wings produce excellent back lobe suppression, so that high ratios of front to back radiation are obtained, and therefore, offer an ideal solution to the protection problem ever present in directional antenna installations.

The Supergain antenna is usually fed by a single transmission line. A notch type diplexer is used at the transmitter. A recent development incorporated in the antenna is a power equalizer that tends to make all dipoles take equal power.

The figures shown are more or less self explanatory, but some of the connection schemes bear additional comment. Figs. 2 and 3 are patterns obtainable when the radiators are arranged for turnstiling. The solid line is for visual pattern and dashed line indicates aural, or vice versa. Figs. 4 and 5 illustrate what can be done if all currents are excited in 0° or 180° phase relation. Still other variations of pattern not shown are available through proper dipole connection.

FIG. 1. Model of the new Supergain TV antenna, shown at left, is the first in the industry to permit gain of twenty and higher. The antenna, consisting of dipoles backed by reflecting screens, can be made to radiate directional or non-directional patterns.

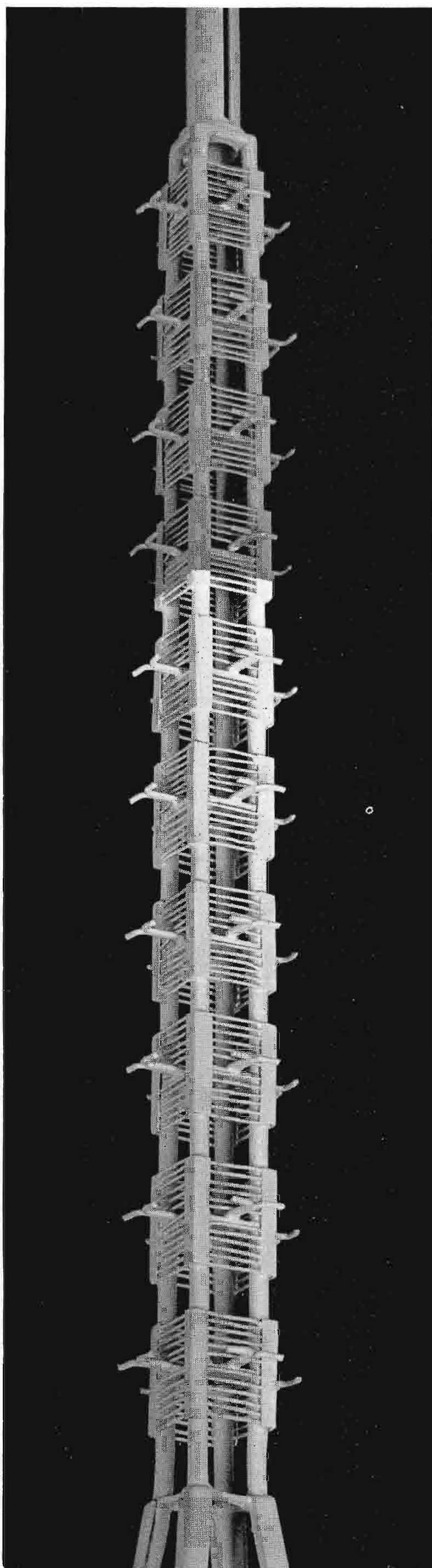
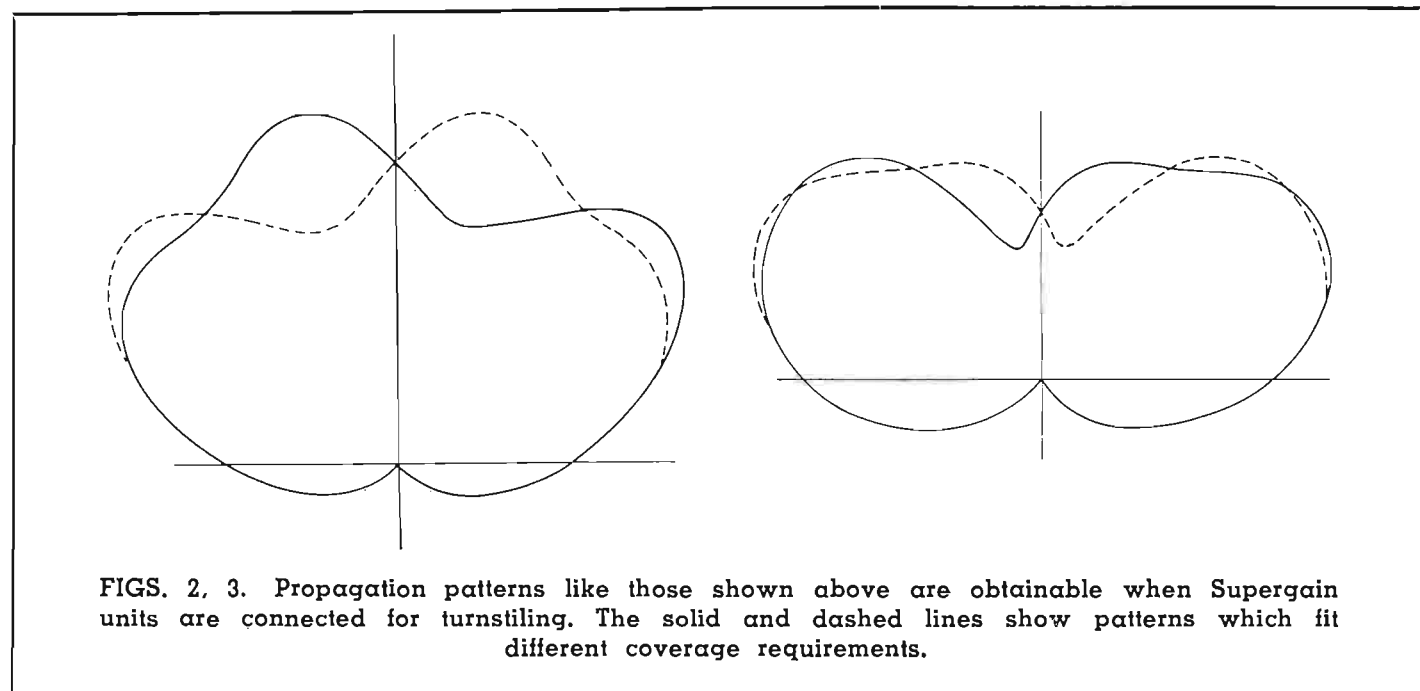

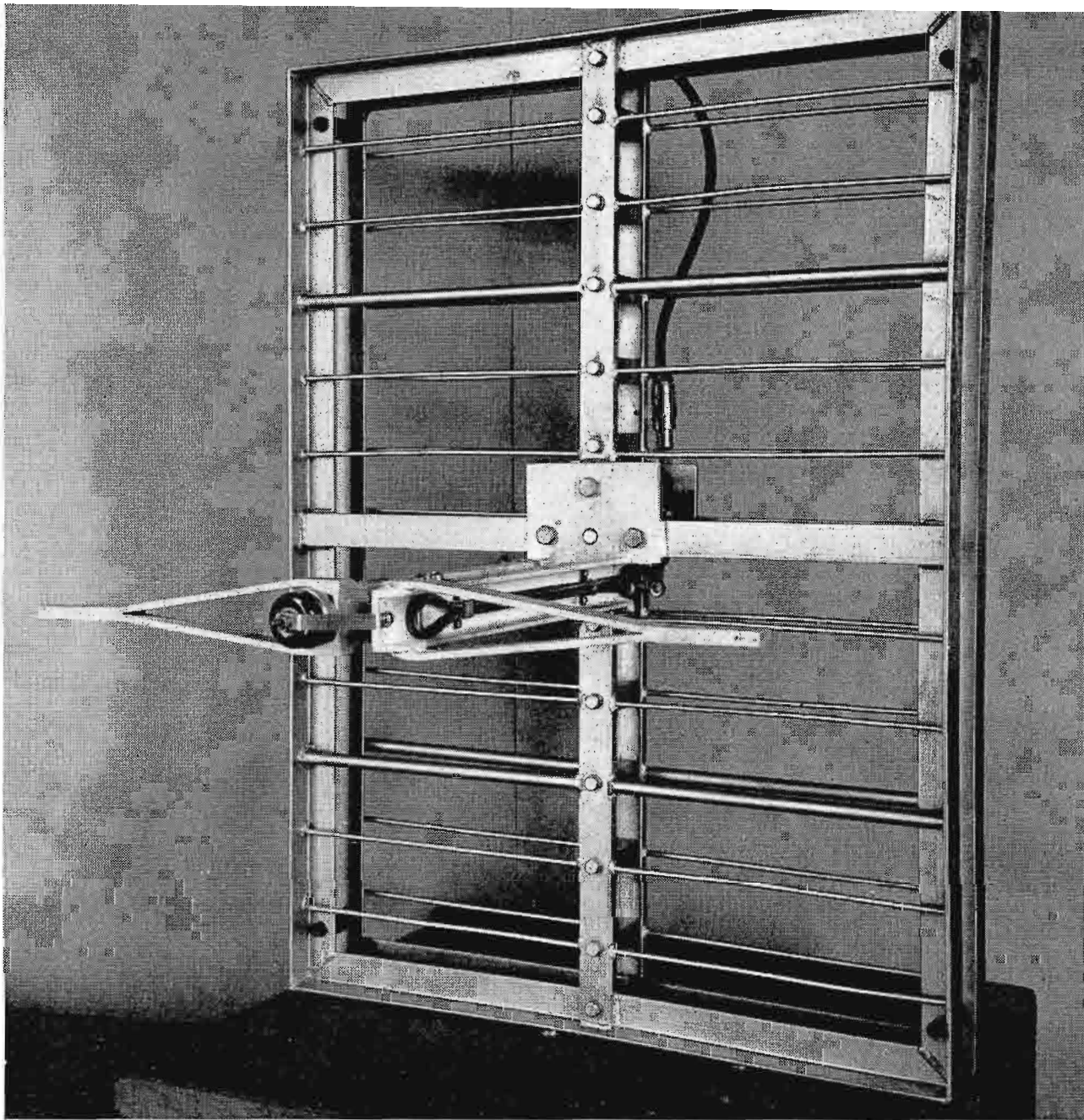

FIG. 6. Photo of Supergain developmental model shows dipole and reflecting screen of one section. Rectangular shielding wings, which are connected to the screens at an angle of 135 degrees, are not shown in this photo.

The impedance characteristics of the Supergain Antenna are such that the antenna could operate over a 25% band width with an 87% impedance match or better, should the necessity arise. No such operation is expected, but there is good insurance in the large band-width index that little change if any in tuning would occur due to icing.

No upper limit on power gain has been found for the Supergain Antenna. A practical limitation of 24 layers has been set as an interim maximum pending further study. The ultimate limit may be reached

due to narrowing of the beam in the vertical plane rather than by structural complications. The radiators are spaced a nominal 0.9 wavelength apart vertically so that a close approximation to a uniform current distribution throughout the height of the antenna is achieved. It is well known that the power gain over a dipole of a uniformly excited antenna whose height is

FIG. 7. The RCA Supergain TV Antenna can be used to support a Pylon and a Superturnstile Antenna as shown in photo of model at right. Using this scheme, two TV stations can share the same antenna tower.

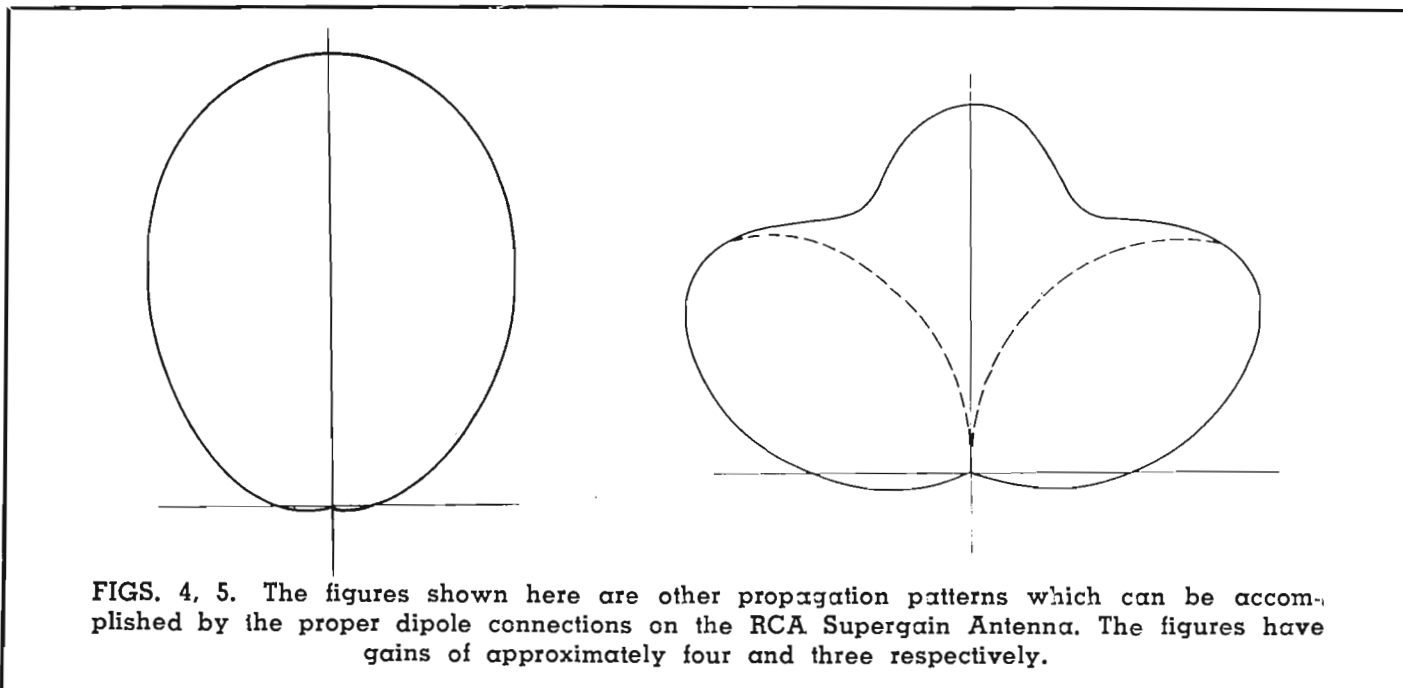
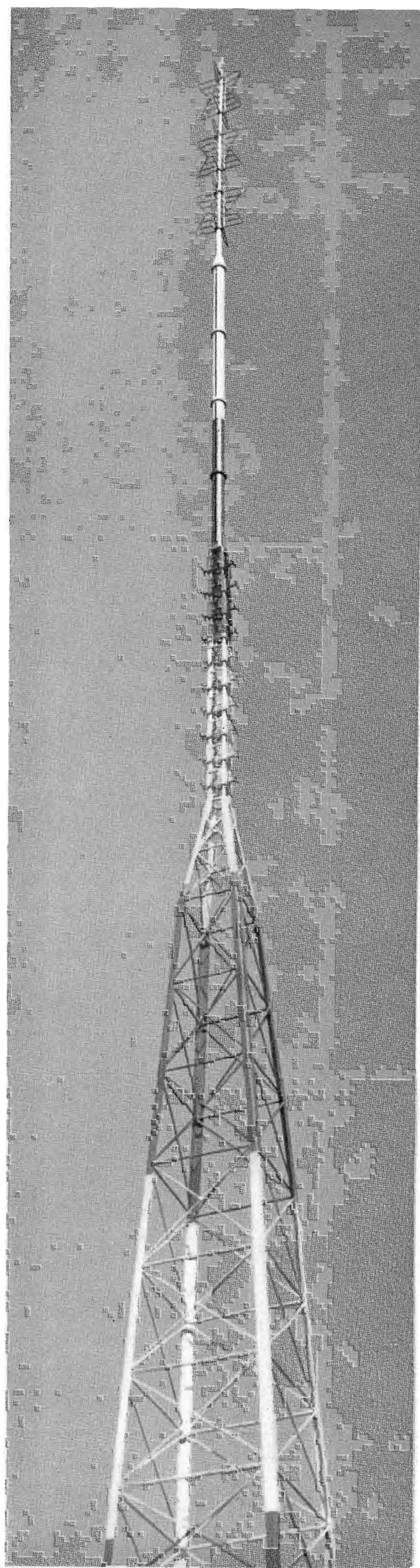

FIGS. 4, 5. The figures shown here are other propagation patterns which can be accomplished by the proper dipole connections on the RCA Supergain Antenna. The figures have gains of approximately four and three respectively.

greater than two or three wavelengths and whose pattern is circular is given accurately by

$$\text{Gain} = 1.22 H, \quad (1)$$

where H is the effective height in wavelengths. Since each bay of the Supergain Antenna, whose dipoles are spaced S wavelengths vertically, closely approximates, in array, an equal section of uniformly excited vertical aperture, (1) becomes

$$\text{Gain} = 1.22 \times S \times n, \quad (2)$$

where n is the number of bays of dipoles. Since S is nominally equal to 0.9 wavelength, the nominal gain of the antenna is given by

$$\text{Gain} = 1.1 n. \quad (3)$$

These values are understood to be average values taken throughout the 360° azimuth angle, and therefore do not include the

plus and minus variations due to the small deviations from circularity naturally inherent in the omni-directional Supergain Antenna. These deviations will be in the order of plus or minus one db.

The gains of the directional patterns are all different, and are greater than the average gain of the omni-directional antenna of the same height by factors ranging from 4.0 in the case of Fig. 4 to 2.85 for Fig. 2. These directional gains are calculated relative to a circle by finding the ratio of the maximum power in the horizontal direction to the average power in the horizontal. This result is multiplied by the gain due to vertical height of a circular antenna to find the final directivity gain of the antenna. Gains are then referred to the location of the main junction box by accounting for the small loss in the branch-

ing lines of the distribution system in the antenna.

It is worthwhile to mention that it is possible to alter the branch feed system of the antenna to permit the beam to be tipped downward a small angle from the horizontal. It has not been thoroughly proved that this is a desirable thing to do in all cases, but there are definite indications that improved performance in some instances may be obtained. This is especially true in locations where the antenna is very high and the area to be reached lies under the beam.

The RCA developed Superturnstile antenna will continue to be standard for television broadcasting for values of gain up to about seven. For power gains higher than this and for special radiation patterns, the Supergain will become increasingly important.



ED MEEHAN

ED MEEHAN REPRESENTATIVE IN DALLAS

Edward (Ed) J. Meehan, Jr., has been named Sales Representative for RCA Broadcast and Television equipment in the Dallas Region, which includes the southeastern part of Texas and a portion of Louisiana. His office is located at 1907-11 McKinney Avenue in Dallas.

Ed joined RCA in 1946 as a Sales Engineer and devoted most of his time to specialized aspects of television station operation. He organized the RCA Television Technical Training program, a series of clinics which provided instruction to more than 500 broadcasters.

Mr. Meehan is a native of Philadelphia, where he was graduated from St. Joseph's College with the Degree of Bachelor of Science. His military service included flying duty with the R.A.F. and the United States Army Air Force, for which he received five combat decorations. He worked on the design of radio countermeasures at the Harvard Radio Research Laboratory. Later, he furthered this development work at the Radiophysics Laboratory at the University of Sydney.

Ed has been active in "Ham" radio for the last fifteen years. His call letters are W3FPW.

REX RAND GOES TO ATLANTA

G. E. (Rex) Rand has been appointed RCA Broadcast Equipment Sales Representative in the Southeastern Region and will serve broadcasters in Eastern Georgia, South Carolina, and Florida. His office address is 522-33 Forsyth Building, Atlanta, Georgia.

A native of London, England, Rex has made his home in the United States since 1946, when he joined the sales group of the RCA Engineering Products Department dealing with broadcast transmitters, audio equipment, and antenna phasing equipment.

Rex is a graduate of St. Andrews University, Scotland, and Oxford University in England with degrees in Electrical Engineering. Following his graduation he participated in British Broadcasting Company and British Communication activities. While serving as an officer with the R.A.F., he received extensive training in radio communications. A large part of his flight course was taken near Miami, Florida, which is now part of his sales territory.

Mr. Rand is an associate member of the IRE and the American Designers Institute. He is also a member of the Solo Flying Club and the Air Force Association.

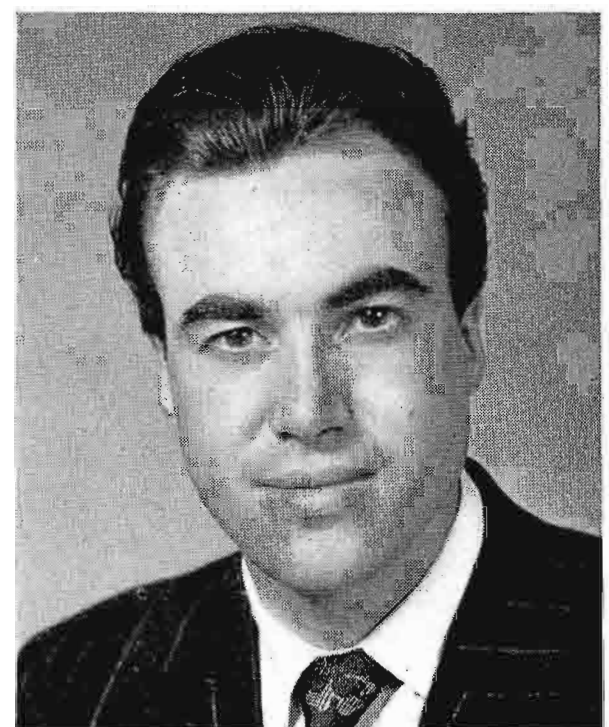

REX RAND

NEAL McNAUGHTEN APPOINTED DIRECTOR OF NAB DEPARTMENT OF ENGINEERING

Neal McNaughten has been appointed director of the National Association of Broadcasters' Engineering Department, the office of NAB President Justin Miller has announced.

Mr. McNaughten succeeds Royal V. Howard, who has resigned to return to private engineering activity.

The new director joined the staff of the National Association of Broadcasters January 1, 1948, as assistant director of the department.

Before coming to NAB, he was with the Federal Communications Commission for seven years. From 1945 to 1948, he was chief of the Allocation Section in the FCC's Engineering Department, Standard Broadcast Division, in which position he administered the Commission's NARBA (North American Regional Broadcasting Agreement) activities.

Born in Pueblo, Colorado, in 1911, Mr. McNaughten entered the broadcast field in 1929 at KGHF, Pueblo. In 1934 he became Chief Engineer at KRGV, Weslaco,

Texas, and remained at that station until his FCC appointment in 1941.

His first FCC assignment was in 1941 to the West Indies, where he assisted in the development of the FCC's radio intelligence operations in that area. In 1942 and 1943 he was Assistant Supervisor of the FCC's Great Lakes monitoring area, in charge of the primary monitoring station at Allegan, Mich. In 1944 he was transferred to Washington as Assistant Chief of the Treaty Section, International Division. He was affiliated with FCC representation on IRAC and the Radio Technical Planning Board, and assisted in the first studies of allocation problems for the Atlantic City International Telecommunications Conference.

Since joining the NAB, Mr. McNaughten has assisted the former director in holding two annual NAB Broadcast Engineering Conferences. He has appeared before FCC in behalf of NAB, served as member and chairman of many subcommittees on preparatory work for the third NARBA Con-



NEAL McNAUGHTEN

ference, and has just recently completed the 675-page fourth edition of the NAB Engineering Handbook.

As vice chairman of NAB's Recording and Reproducing Standards Committee, he has devoted a considerable amount of his time to the development of disk and magnetic standards for the broadcasting industry.

NEW NAB ENGINEERING HANDBOOK CONTAINS WEALTH OF INFORMATION

The 1949 edition of the National Association of Broadcasters' famous *Engineering Handbook* has gone to press, and will be available to broadcast engineers throughout the continent and Latin America about the middle of September according to an announcement made by Neal McNaughten, NAB Engineering Department director.

The handbook was originally scheduled for August 15 publication but was delayed slightly by production difficulties.

Revised and greatly enlarged this year, the handbook has 675 pages, in a new, permanent post binder, capable of expansion to four inches. It contains FCC Rules and Regulations, Standards of Good Engineering Practice, design data, material on television, FM, AM, audio engineering, and a completely catalogued "wealth of information of constant daily usefulness." Section (chapter) headings include: (1) Regulations-Standards, (2) Transmitter, (3) Studio, (4) Field, (5) General Engineering, and (6) Charts-Graphs-Table-Notes.

The section on regulations and standards includes the FCC Standards of Good En-

gineering Practice for Standard, FM and Television Stations. It also includes FCC rules on operators and remote pickup stations, and various other standards, as well as information on broadcast services such as the WWV frequency transmissions.

Each of the sections on transmitter, studio, field and general engineering includes a number of selected articles containing up-to-date information on the most important aspects of the subject, plus digests of engineering notes obtained from the engineering departments of equipment manufacturers, networks and consulting firms. Much of the latter is hitherto unpublished information not generally available elsewhere.

The final section contains a large number of exceedingly useful charts, tables, etc., which have been carefully chosen for their applicability to the field of broadcast engineering. Some of these have been previously published, however; many are new to the 1949 edition.

In selecting and assembling the great wealth of material in the 1949 Handbook, the NAB Engineering Department has

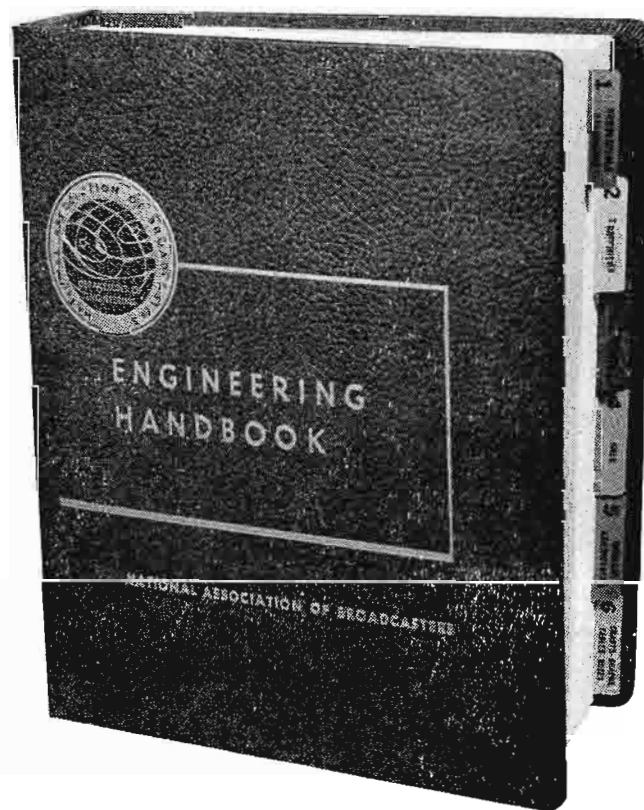

done an outstanding job—one that reflects a real knowledge of the needs of station engineers.

The handbook will be sent free to all NAB members, and will be offered for sale additionally at \$17.50 in a severely limited edition.

In addition to orders for the handbook from United States engineers, the NAB Engineering Department is already receiving orders from stations in other nations of the Americas.

BASEBALL TELEVISION : 1949

AN UP-TO-DATE SURVEY OF EQUIPMENT SETUPS, OPERATING TECHNIQUES, CAMERA SWITCHING, MONITORING, ANNOUNCING AND PRODUCTION OF COMMERCIALS IN 31 STATIONS TELECASTING BASEBALL SCHEDULES IN 1949

by **JOHN P. TAYLOR**

Engineering Products Department

Two years ago we published in *BROADCAST NEWS* a "round-up story" on baseball television.¹ A round-up story, in copywriter's lexicon, is an article which surveys the work being done in a particular field by all of the people working in that field—and attempts to summarize their experience in a sort of status report.

At the time (August 1947) there were only eleven TV stations on-the-air—only nine of which were carrying baseball schedules. It was not very hard, therefore, to get information on what all of them were doing. Summarizing was more difficult—for we found there was much difference of opinion on such subjects as the best positions for cameras, number of cameras, switching sequences, etc. However, we did the best we could with the material, and it must have been of considerable interest for our supply of that issue of *BROADCAST NEWS* has long since been exhausted, and we still receive frequent requests for reprints.

In the two years which have passed since the original article, the number of TV stations on the air has increased to 77, and the number telecasting baseball to 31. Thus the sum total experience (in man-years) of the industry in televising baseball has increased by perhaps tenfold.

Has this added experience answered the questions raised by the earlier survey? Have new gadgets—such as the Zoomar lens—made any marked differences? Has the technique "jelled" to the point where standard procedures can be described? To find out, we decided to make a new and up-to-date survey.

Inasmuch as it was obviously impossible to visit all stations we sent to each a fairly detailed questionnaire and a request for diagrams and photos of their baseball setup. Answers were received from all but a few. These answers—amplified by a number of on-the-scene reports, visits to

several stations, and observations of games as broadcast by stations in the East—form the basis for the article which follows.

This article is arranged as follows. First there is a section, Page 8 to Page 18, which summarizes baseball TV experience to date. Following this there is a section, Page 19 to Page 27, which contains data on camera use and placement for all stations televising baseball this year. (We've done our best to make this complete, but it is possible that we missed one or two.) Included in this section are illustrations of camera setups at all stations from whom photos were received. Finally, there is a section—really a complete story in itself—giving a detailed description of WPIX's baseball operation.

We picked WPIX for the windup—first, because the New York Daily News station is making something of a name for itself as a sports station; second, because they rely largely on the use of a Zoomar lens—and we wanted to show graphically how the use of the Zoomar affects the operation (especially the camera switching). Readers who have a file of *BROADCAST NEWS* will be able to do this very effectively by comparing the WPIX camera switching sequences (Page 36) with the similar sequences for WPTZ which were included in the earlier article.

Scope of the Discussion

Our theory is that *BROADCAST NEWS* performs its job best when it is of the most usefulness to its engineer readers. This means that its pages are ordinarily limited to matters of planning, installation, operation and maintenance of broadcast equipment. It may, therefore, surprise some of our readers to find that we have included in this article such matters as camera switching and commercials—which are usually prerogatives of the production department. The answer is that in TV the engineer has to plan carefully all remotes, for a TV remote is a very complex operation—much more so than a standard broadcast remote. In order to make his decision on what equipment to use, and where to locate it, the engineer must have a precise knowledge of how it is going to be used. This means he must be interested

in and familiar with the whole operation—and the following discussion is based on the assumption that he is.

The paragraph subjects of the discussion are arranged in the order they would normally be taken up in planning a baseball installation. However, it should be noted that this article is a review rather than a primer. Considerable knowledge of the subject by the reader is assumed. Those approaching the subject for the first time will fair best if they will read through the whole presentation quickly, then go back to study the details—rather than trying to master each detail on the first reading.

General Arrangement

The general arrangement of technical facilities for a TV baseball pickup is pretty well standardized. The diagram of Fig. 1 which shows WLW-T's setup at Crosley Field is typical. Cameras and cameramen are located at vantage spots in the stands. Coax cables run from the cameras to the camera control equipment, which is ordinarily located in a mobile unit parked just outside the park. A program director at this point gives his instructions on camera pointing to the cameramen (by intercom) and on camera switching directly to a technical supervisor who "pushes the buttons."

From the mobile unit video signals are fed to the main transmitter location by microwave relay—the transmitter parabola ordinarily being mounted on the roof of the grandstand or on one of the park lighting towers, and the receiver parabola on the main antenna tower. The only variations from this standard setup are as follows: (1) a few stations place the control equipment in a room under the stands, (2) some stations send the microwave signal to the master control room location rather than the transmitter, and (3) one station uses Telco coax between the park and master control.

Despite this agreement on general arrangement, however, there are many different ideas on such details as number of cameras, locations of cameras, choice of lenses, camera switching sequences, etc. These are discussed at length in the paragraphs that follow.

¹ "Camera Placement and Switching for Baseball Broadcasting," by John P. Taylor, *BROADCAST NEWS*, Vol. No. 46, September 1947.

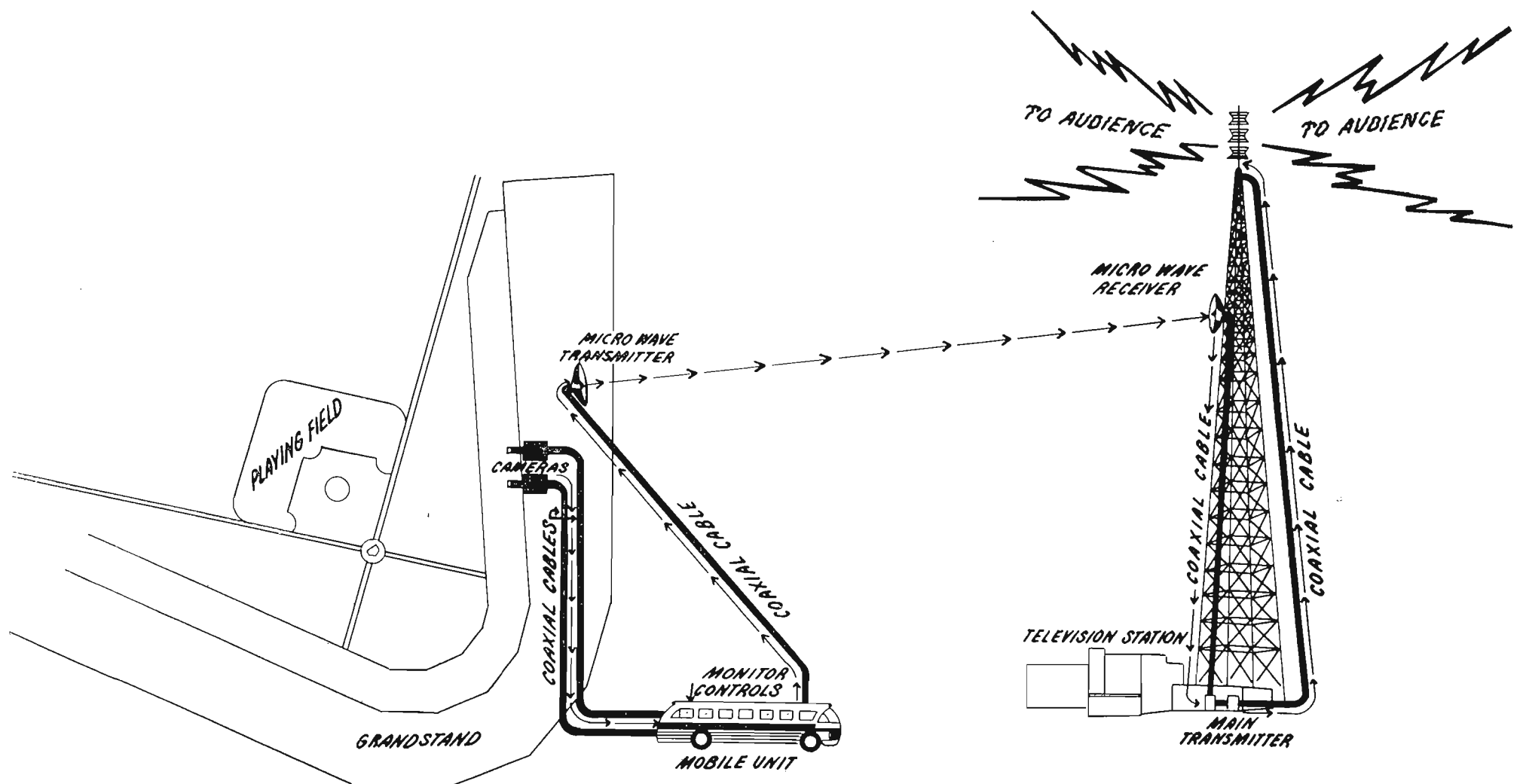

FIG. 1. Standard arrangement of facilities for TV baseball pickups. Cameras are located at best viewing spots in stands. From these positions coax cables feed video signals to control position located in mobile unit usually parked behind stands. Video signal selected for transmission is sent by microwave relay unit (mounted on top of grandstand) to either the main transmitter (as shown above) or to the studio master control location. Diagram above shows WLW-T's setup at Crosley Field, Cincinnati. WLW-T has since added a third camera which is located just behind homeplate and uses a Zoomar lens.

Number of Cameras

Sixteen of the stations televising baseball use three cameras, the other fifteen use two. Economics has much to do with this decision. Of the fifteen stations telecasting major league games ten use three cameras, while five use two cameras. This indicates that when the money is available three cameras are the choice. In fact, of the five stations doing major league ball with two cameras, three are accounted for by the Philadelphia stations (WPTZ, WCAU-TV and WFIL-TV). The WPTZ crew makes the pickup for all three stations. This crew is probably the most experienced in the country (they've done 154 games a year for a number of years). Their cameramen are adept at doping the plays out ahead of time and their directors call the shots with machine-gun precision. Thus they do with two cameras what less experienced crews do with three.

There is no question that three cameras make the director's job easier. This is especially so with runners on base. For instance, with a man on 1st the third camera can be instructed to "stay with the runner." Then, if a double play develops the director has available a closeup at 2nd without taking his No. 1 away from its normal job of following the ball or his No. 2 from its usual closeup of 1st base. This contrasts with the two-camera setup

where the director must either be satisfied with a long shot at 2nd (with his No. 1 Camera) or else instruct his No. 2 Camera to follow the runner, in which case he loses his closeup at 1st (unless No. 1 can make an exceedingly fast switch). With more than one runner on base the advantage of the third camera is even more striking. (The discussion of switching sequences on Page 16 will make this more clear.)

There are two other minor advantages to the three-camera setup. One is that the third camera may often be placed at a different location and thereby provide a favorable picture of some part of the park (such as dugout, stands, bullpen, etc.) which is out of view of the other two cameras. A second is the insurance it gives against possible failure in No. 1 or No. 2 Cameras, which would otherwise require continuance of the game on one camera (a very dull procedure). It is probably this last, as much as any, that prompts most of the big city stations to use three cameras.

Despite these obvious advantages of the third camera, it is not an open-and-shut case. Use of the extra camera ties up expensive equipment and it requires at least one additional man (the No. 3 cameraman), probably a second (an extra video operator) and possibly a third (a relief man on double headers). This considerable

extra cost must be measured against the possible advantages. The fact that WPTZ, with two cameras, does a job which some have called the best in the business shows that "two-camera" directors need not have an inferiority complex.

Location of Camera No. 1

Once the number of cameras has been decided on the next step in planning a baseball pickup is to decide on the location of the cameras. In many, if not most, cases the restrictions imposed by the construction of the stands, the size of the field, the direction of the sun or the inevitable limitations of space, time and sometimes money, will make it impossible for the engineer to obtain the locations that would provide the best coverage. However, even in the most difficult situations it will be of some help to be able to state definitely the comparable advantages and disadvantages of the possible locations. The engineer who can predict results with conviction is much more likely to get what he wants than the one who sprinkles his recommendation with ifs and maybes.

The past two years has seen no startling innovations in placing of cameras—and no great change in thinking on the subject. However, the greater amount of experience makes it possible to formulate the principles of camera placement with greater



FIG. 2. THE CASE OF THE FIVE BASEBALLS—OR WHY IT IS SO HARD TO GET A GOOD PHOTOGRAPH FROM THE MONITOR SCREEN. The picture above was taken at an exposure of $1/12$ second. During this time the cathode ray beam traced five non-interlaced fields on the kinescope screen—hence, five pictures of the ball. Similarly there are five baserunners coming into view at left. At first glance there appears to be only one picture each of the stationary figures of the umpire and first baseman. This of course, is an illusion—there are actually five pictures of each of these men, too. In this case, however, the pictures almost coincide—but not quite, because these men also moved a little. As a result the outlines are blurred. And that is what occurs on nearly all kinescope pictures of action scenes. Of course, you can use a shorter exposure—but even at $1/25$ th you get two fields. The eye, of course, sees it differently. Instead of five separate pictures it sees a moving picture—with the apparent detail of one of the single pictures. This difference should be kept in mind when looking at “pictures from the kinescope,” shown on following pages.

certainty—and to state the reasons more clearly.

It is, for instance, now an accepted principle that the No. 1 camera should be located to give the best “standard” or “cover” shot (i.e., the shot which is used as the pitcher winds up and throws, and which is usually on the screen from the time the batter comes up until he hits the ball). Two years ago we suggested that, inasmuch as the camera “sits” on this shot better than half the time, it was only common sense to make the decision on the

location of the No. 1 camera chiefly on the basis of which location would give the best standard (or “cover”) shot. The original suggestion was based on the experience of a very few station directors and hence was put forth rather tentatively. However, in the light of the much greater experience now available we can state unequivocally that the first principle in camera location is “*put the No. 1 Camera where it will give the best cover shot.*”

Where should No. 1 be to give the best camera shot? Most directors say “*directly*

behind homeplate, and not too high.” Their reasoning is fairly simple. They feel that most viewers want to see the plate umpire, catcher, batter and pitcher, during most of the time. While some baseball addicts might like a big closeup view of the ball breaking across the plate, and the batter taking a cut at it—the average viewer is less confused and better able to follow the game if he sees the ball continuously. In fact, the idea of letting the viewer “*see the ball all the time*” might be stated as the second fundamental principle.

FOUR VARIATIONS OF THE "STANDARD" OR "COVER" SHOT

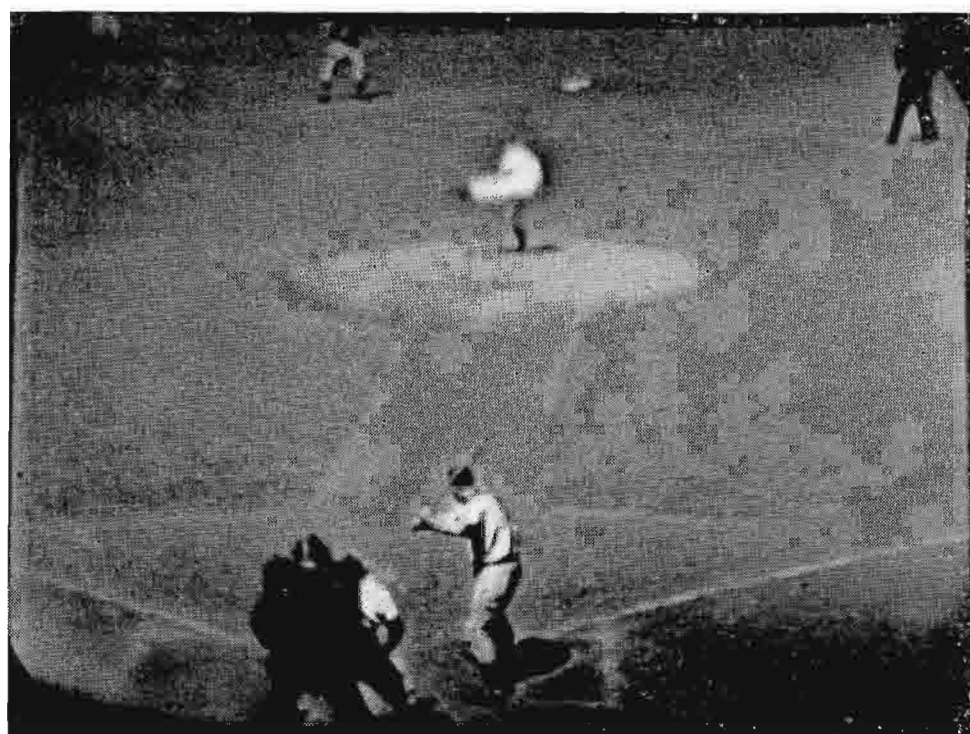

FIG. 3. WPTZ COVER SHOT made with a 135mm lens on a camera 20 feet high, 50 feet behind homeplate.

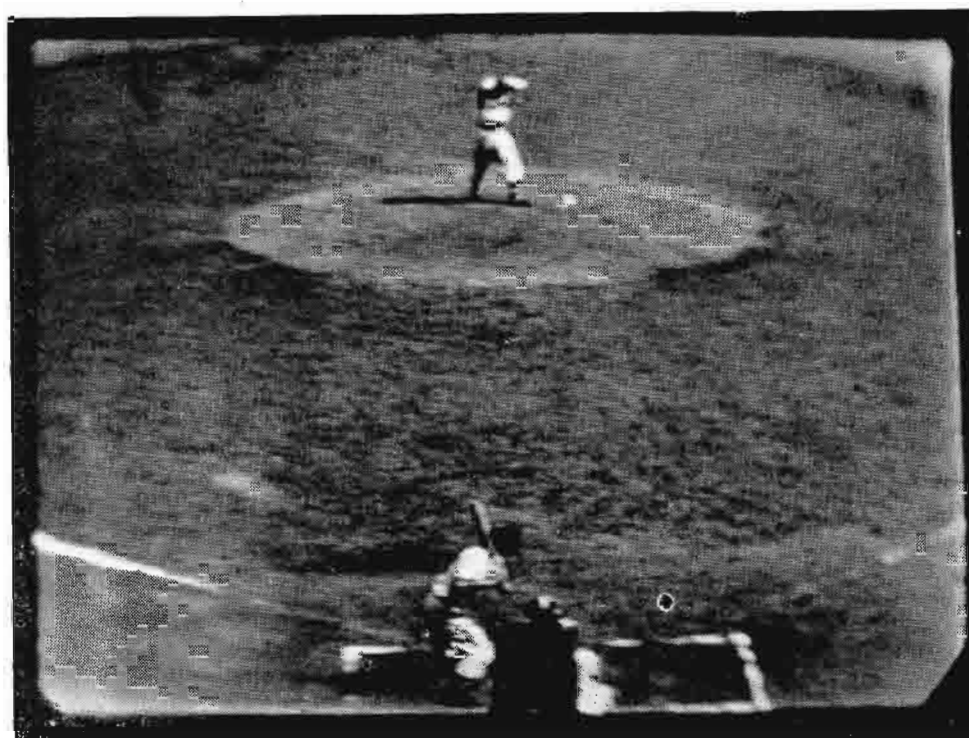

FIG. 4. WPIX COVER SHOT made with a Zoomar lens on a camera 40 feet high, 84 feet behind homeplate.



FIG. 5. WTTG COVER SHOT made with a 4" lens on a camera 27 feet high, 75 feet behind (slightly to right of) homeplate.



FIG. 6. KSD-TV COVER SHOT made with a 135mm lens on a camera 35 feet high, 85 feet from plate along 1st base line.

It is possible to get a picture of the umpire-catcher-batter-pitcher area from almost any location in the stands. However, from any position except that directly behind homeplate a fairly wide angle lens (usually 50mm) is required—and when such a lens is used the figures “look like ants,” as one director puts it. On the other hand a camera behind homeplate sees all four figures nearly in line and hence a lens of relatively narrow angle (usually a 135mm) may be used, providing the camera is not so high that the vertical angle becomes the limiting factor (Figs. 3, 4, 5).

There is another important advantage in the behind-homeplate position. This is the fact that it usually results in less panning of the main action camera. To illustrate, a camera back of third base in fol-

lowing a ball hit to the outfield—left field, let us say—will have to pan through an angle of something like 135°. A camera behind homeplate can follow the ball to any point in the field without panning an angle of more than 30° from the batter-pitcher line. Swinging the camera through the wide angle is confusing at the best—at its worst it's dizzy. Either because of these now well-recognized facts—or by the trial and error method—most directors have decided on the homeplate position. Of the 31 stations scheduling baseball, 24 have the No. 1 camera behind the plate, and at least half of the remainder indicated that they would have it there if they could.

Despite the preponderant choice of the homeplate position it is only fair to note

that there are some dissenters. One of these is Capt. Bill Eddy, former manager of WBKB, who with Phil Wrigley made an extended study of the subject in 1946. This led to the well-publicized setup used by WBKB at Wrigley Field. As originally installed all the cameras in this setup were along the 3rd base line, one being at ground level near the dugout, one in the stands back of third base, and the third in the far left field stands near the foul line. The biggest advantage claimed for this system (as compared to having the No. 1 Camera behind homeplate) is that it results in most of the action developing “into the camera” rather than away from it. Eddy and Wrigley picked this idea up from a study of movie techniques. There is no question that action developing into

FOUR VARIATIONS OF THE No. 2 CAMERA SHOT



FIG. 7. WPTZ NO. 2 SHOT made with an 8½" lens on a camera 65 feet high, 50 feet behind (slightly to right of) homeplate.



FIG. 8. WPIX NO. 2 SHOT made with an 8½" lens on a camera 40 feet high, 102 feet from plate on 1st base side.



FIG. 9. WTTG NO. 2 SHOT made with an 8" lens on a camera 27 feet high, 75 feet behind (slightly to right of) homeplate.

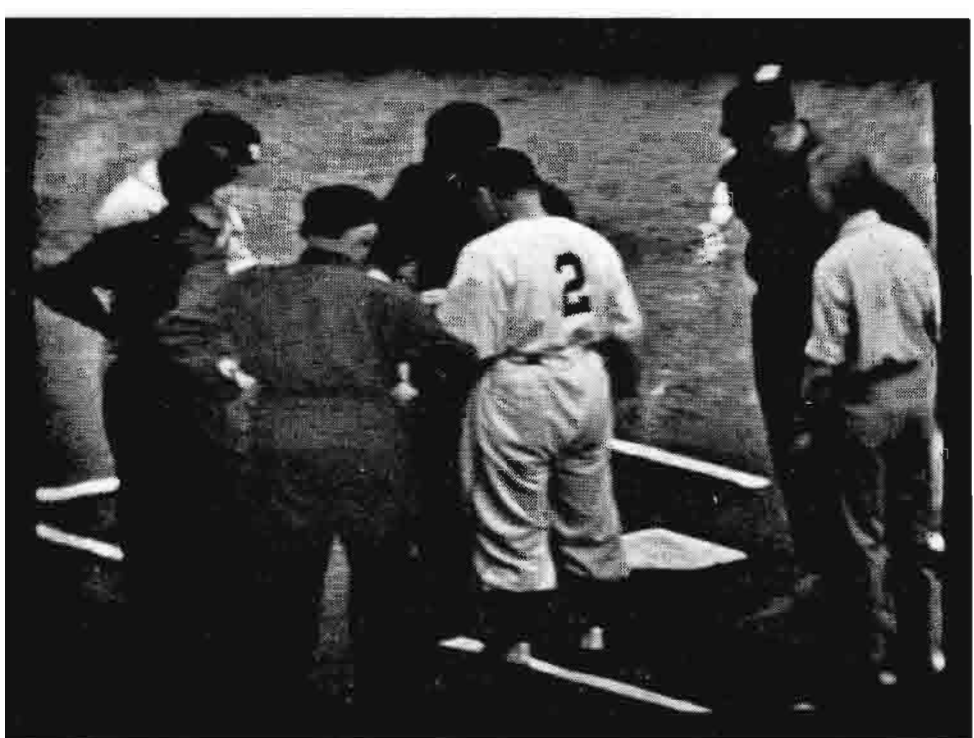

FIG. 10. WPIX NO. 2 SHOT made with a 17" lens on a camera 40 feet high, 102 feet from plate on 1st base side.

—i.e., moving closer and closer to the camera—provides a more dramatic effect. In the case of the WBKB setup this is heightened by placing one camera in a pit near the dugout so that the camera (which is mounted on an hydraulic pedestal for quick change of height), can actually look up at the players. Very dramatic shots at 3rd base and homeplate are possible. Second base shots are also good. Their answer to the wide-angle panning ordinarily required by a base-line camera covering overall action is the left field camera which, with a Zoomar lens can "cover" all infield and most outfield plays with a relatively narrow pan.

Despite its theoretical advantages the WBKB setup did not receive too favorable response from the critics and during

the past season the left field camera was moved up beside the No. 2 Camera behind 3rd base.

Several of the stations which use 1st base line positions for all cameras do so because the one-tier stands do not provide a behind homeplate position of the right height—the stands are too low, the roof too high. (This influence of height on choice of camera locations is discussed separately in a following paragraph.) Under these circumstances the director, recognizing his problem, operates a little differently. Rather than have "figures that look like ants" he uses a shot showing only umpire-catcher and batter as his cover shot. In order to get more feeling of the action he may show a closeup of the pitcher during windup and delivery—then switch to his

cover shot while the ball is on its way to the plate. Similarly, to avoid too rapid panning he will switch to his second or third camera on the play rather than following the ball all the way with one.

Location of Cameras No. 2 and No. 3

Location of the second camera, and the third camera if used, is much less critical; and, as could be guessed, there is less uniformity of thinking regarding the best location.

The easiest procedure—from the viewpoint of installation and operation—is to locate Camera No. 2 alongside of Camera No. 1. Proponents of this course can site three definite advantages to support their case. First, the game is presented "as a

TYPICAL "COLOR" SHOTS WITH No. 2 OR No. 3 CAMERA



FIG. 11. WPIX NO. 3 SHOT of visitors' dugout made with a 17" lens on a camera 40 feet high, 102 feet from plate on 1st base side.

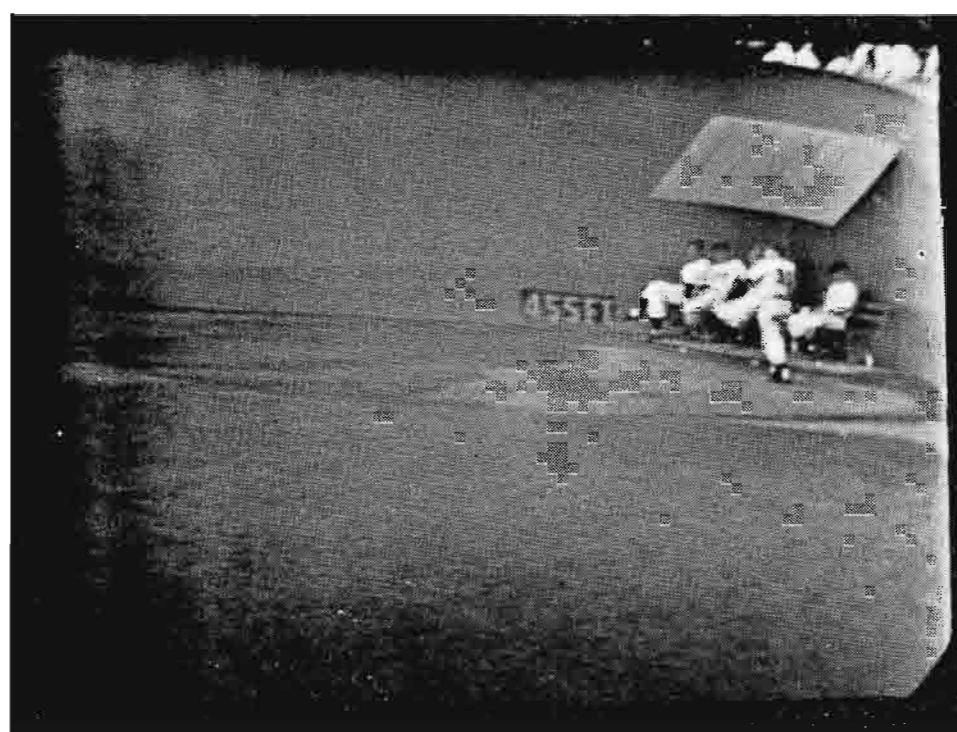

FIG. 12. WPIX NO. 3 SHOT of bullpen in far right field made with 17" lens on a camera 40 feet high, 102 feet from plate on 1st base side.

spectator in the stands would see it"—i.e., from one position. Second, in case of failure in Camera No. 1 the No. 2 Camera can take over the "cover" shot and the audience will not realize the difference. Third, camera switching—because it is not accompanied by a marked change of viewing angle—is less confusing to the viewer. These are all good arguments, although there are some obvious rebuttals. For instance, why should TV be limited in mobility just because the spectator is. Again, cameras don't often break down—and if they do, it's always possible to operate fairly well from a different position (after all, some stations do it all the time). And, finally, careful orientation before switching will prevent confusion.

The disadvantages of locating No. 2 with No. 1 are: first, that if No. 1 is as low as it should be, then it doesn't give the best view of the outfield (because its angle is too low) and, second, that it does not provide the break in monotony which a different position for No. 2 will tend to give.

Suppose it is decided to locate No. 2 at some different location. Where should it be? If No. 1 is at the ideal spot—say about 20 feet high, behind the plate—then there are several alternatives. One of the most attractive (where stands permit) is to have the No. 2 also behind the plate—but high up, at least 50 feet or more. This gives a good view of the outfield, provides some change in scene, and generally does not confuse the viewer. The WPTZ setup (Page 20) is of this type—and it is certainly one of the best.

If more change of view is desired—or if the high-low setup is not practical—then the No. 2 Camera can be located at any height, from medium to high, along either the 1st base or 3rd base line. It must be reasonably high to get the desired view of the outfield. The 1st base side has the advantage of more action (at close range). The 3rd base side presents the more dramatic effect of action "developing into the camera"—but it's dull in one of those close games where few runners get beyond second. The direction the sun shines may be determining—obviously the cameras should not look right into it.

In three-camera setups the No. 3 Camera is usually—but not always—located either with No. 1 or No. 2. Advantage of locating it with No. 1 is that it provides a spare camera ready to take over the "cover" shot in case of failure on No. 1. Advantage of locating it with No. 2 is that usually the latter position is higher (and hence usually better) for the infield and outfield closeups and "color" shots for which No. 3 is used almost exclusively. In the case where No. 1 and No. 2 are on the 1st base line there is an advantage in having No. 3 on the 3rd base side. This makes it possible to get a front view of a left-handed batter (No. 1 and No. 2 will be looking at his back).

No reference has been made in this discussion to the effect the use of the Zoomar lens might have on camera location. As far as we can see, it has no appreciable effect. Stations using Zoomars seem to follow the same pattern of camera locations as those without. And, of course, this is

almost a necessity as long as stations change from Zoomar daytimes to turret lenses nighttime.

Height of Camera Location

The experience of a number of new stations, which have gone on the air in the past two years, indicates that insufficient thought was given in the early days to the importance of camera height. These stations, following the dictum of getting a position behind the plate, placed their cameras in the only available spots. In smaller (usually one-tiered) parks this was either at the front of the lower tier—which was so low that people walked in front of the camera—or on the roof of the grandstand. The latter position, which on first thought seems ideal, usually has turned out to be a disappointment. The reason is apparent when we recall that the reason for choosing the behind the plate position was to get the umpire-catcher-batter-pitcher quartet approximately in line, so that a narrow angle lens could be used. This idea works fine for heights up to 20 or 25 feet. As we go higher (and grandstand roofs are often 50 to 75 feet high) the scheme defeats itself for we soon find ourselves with a wide *vertical* angle. The problem is accentuated by the fact that the 4-3 aspect ratio makes the vertical field of view 25 per cent less than the horizontal. Because of this, several stations which confidently expected to use a 135mm lens for a "cover" shot from their behind-the-plate on-the-roof position soon found that they had to go to a 90mm or even a 50mm to get the pitcher in the picture. Result, those "ants" again.

FIELD OF VIEW WITH SIX DIFFERENT LENS SIZES

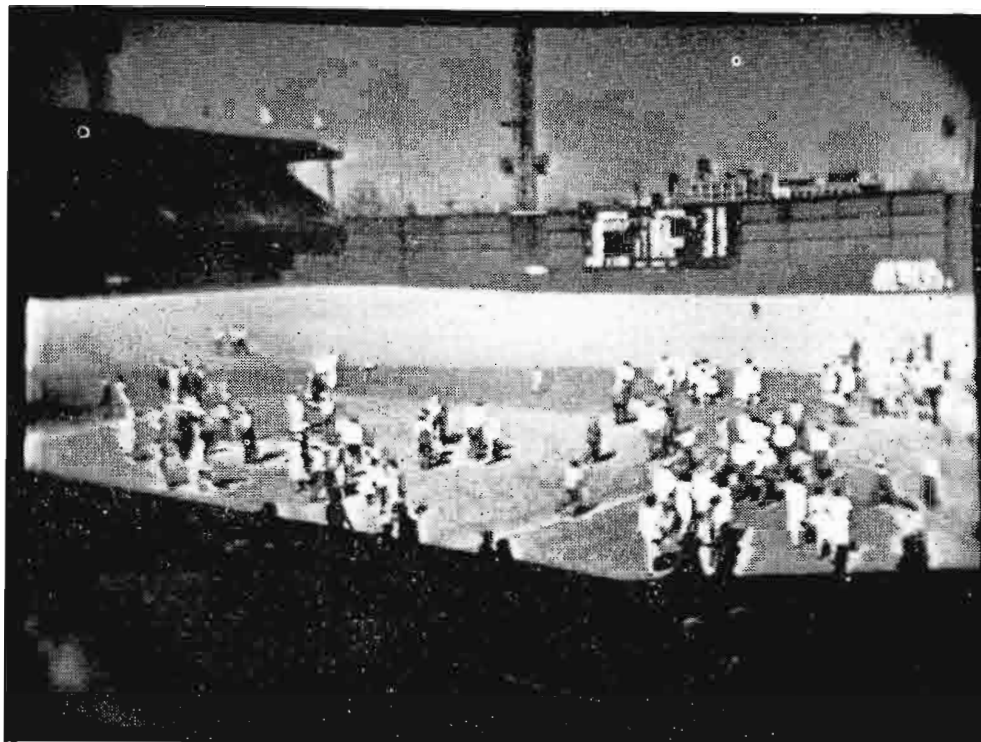

FIG. 13. 50mm LENS on camera 20 feet high, 50 feet behind plate.



FIG. 14. 90mm LENS on camera 20 feet high, 50 feet behind plate.

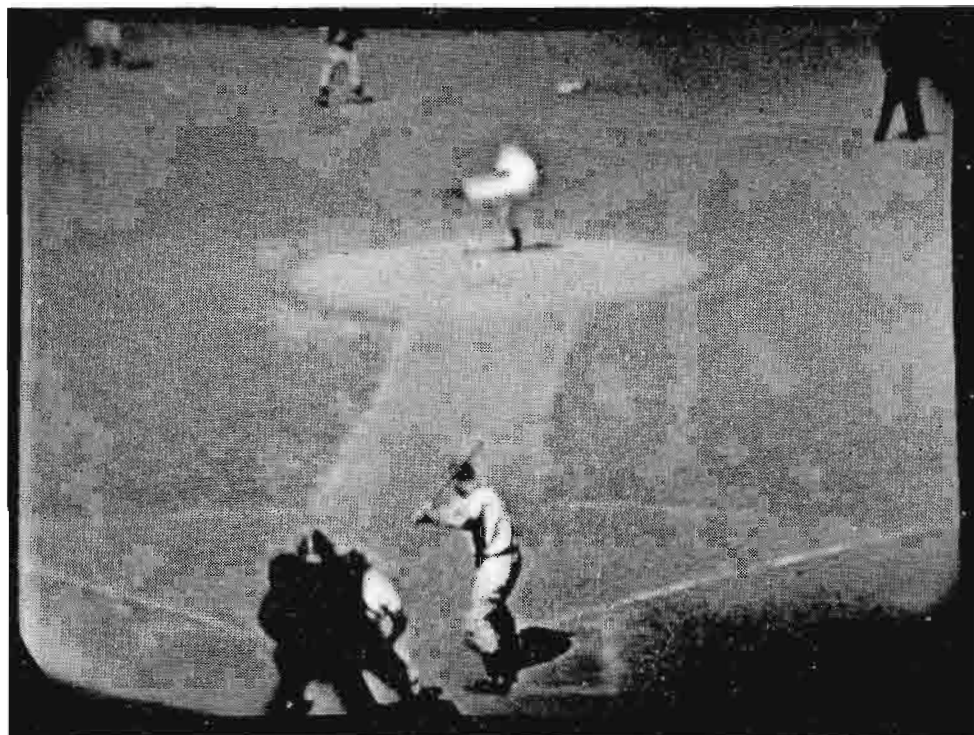

FIG. 15. 135mm LENS on camera 20 feet high, 50 feet behind plate.

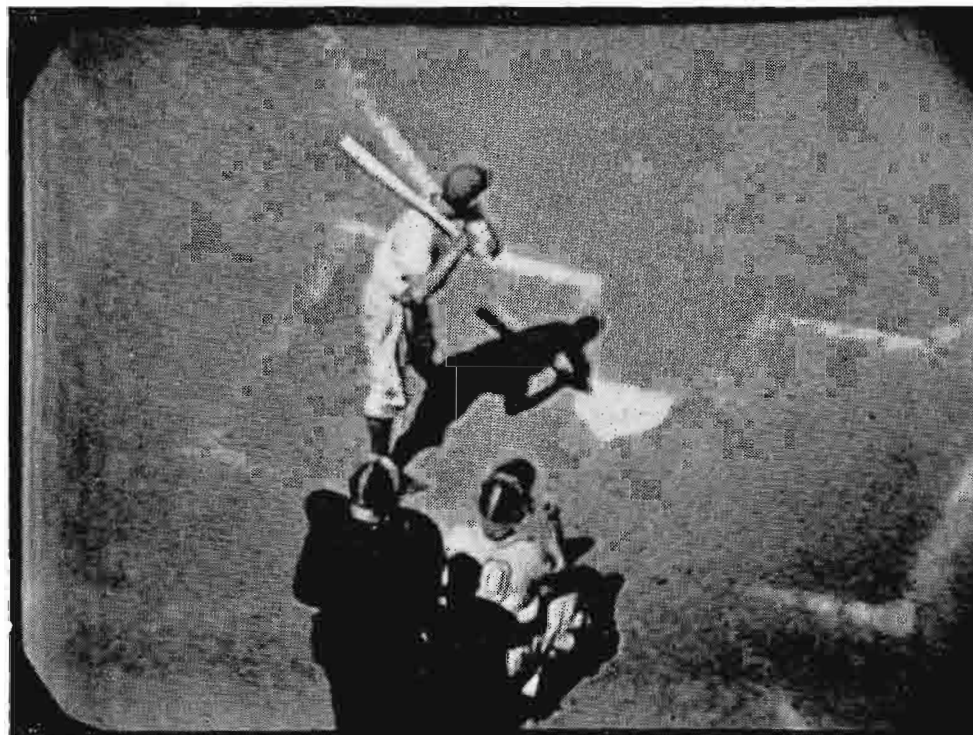

FIG. 16. 8½" LENS on camera 65 feet high, 50 feet behind plate.

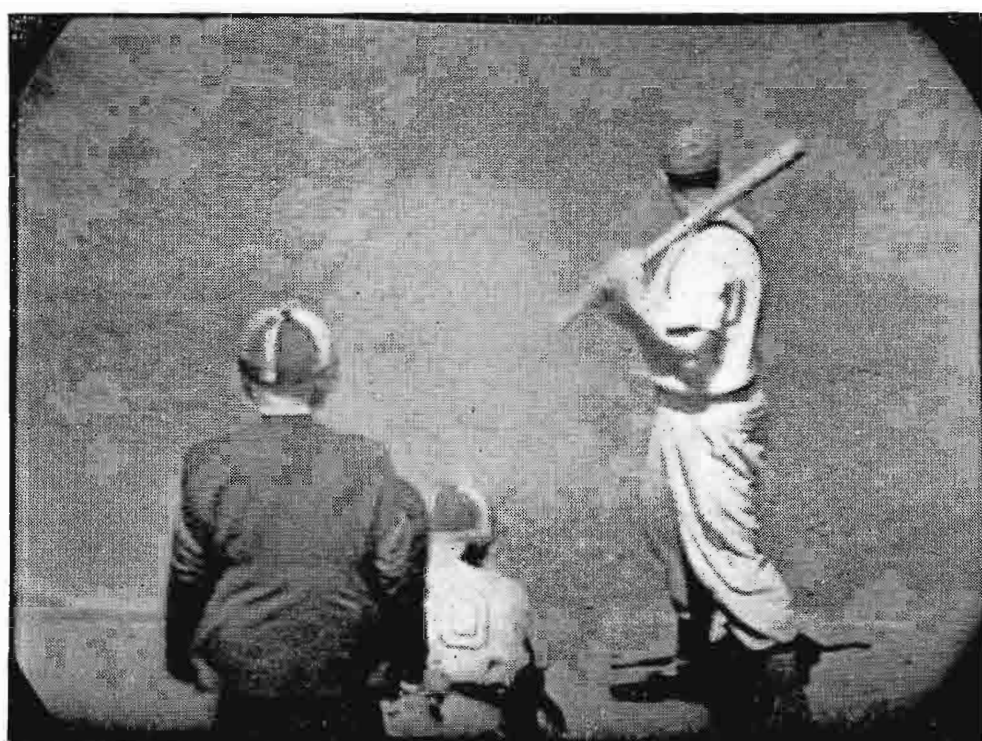

FIG. 17. 13½" LENS on camera 20 feet high, 50 feet behind plate.

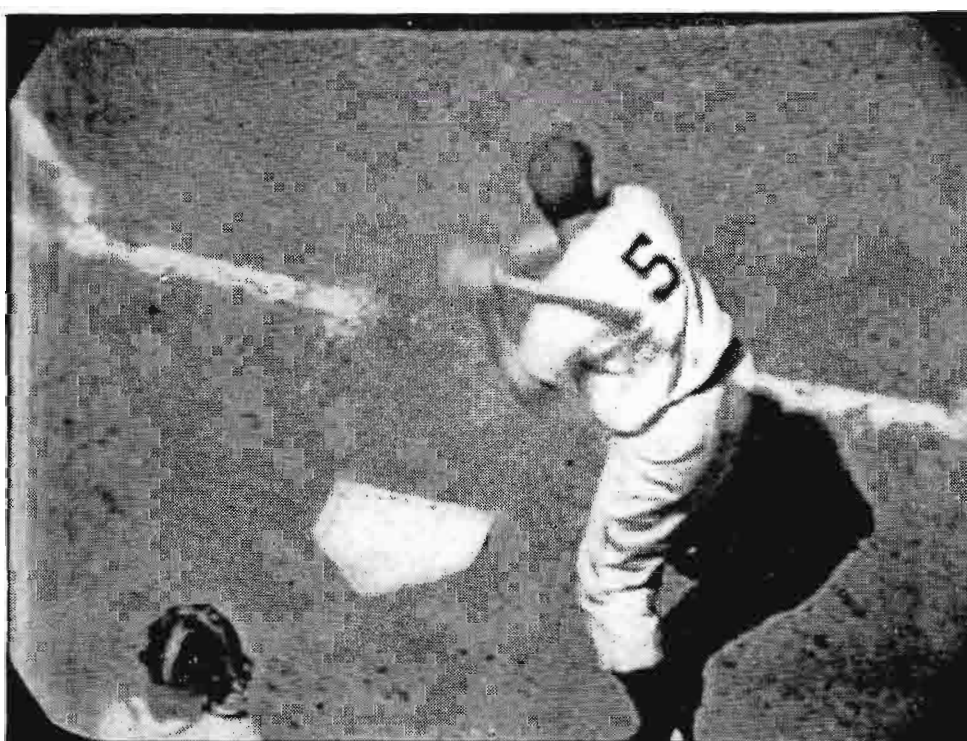

FIG. 18. 17" LENS on camera 65 feet high, 50 feet behind plate.

The problem of getting a location at the right height is not an easy one. In the pages which follow a dozen or more camera setups are shown. It will be immediately evident that most are above or below the ideal height. In a one-tiered stand the only good solution is to build a booth at the rear of the stand—like KGO's (Page 22) or to hang the cameraman in a crow's nest—like WEW's (Page 26). In a two-tiered park the front of the second tier may do—but usually even it is too high. The best solution is to hang a camera cage below the front of the second tier—as WPTZ has done at Shibe Park (Page 20).

In any event, it will be well for the new TV station engineer to bear in mind that the one lament heard most often from baseball TV directors is that "our cameras are too high for ideal operation."

Lenses

Six lens sizes (50mm, 90mm, 135mm, 8½", 13½", 17") are used regularly in baseball television. Where camera locations allow, the 135mm is the overwhelming choice for the standard or cover shot (Fig. 15). The 90mm is the usual choice for the alternate cover shot (Fig. 14) used with a man on base (usually it shows the area from 2nd base to homeplate). The 50mm (Fig. 13) is used (in most cases) only for opening and closing shots of the field, crowd, etc. The 8½" (Fig. 16) is used for medium or group closeups—i.e., the umpire, catcher and batter; or the 1st baseman, a base runner and the coach at 1st. The 13½" and 17" (Figs. 17, 18) are used mostly for individual closeups, dug-out shots, crowd shots in the far stands, etc. Lenses larger than 17" are seldom used for two reasons. First, they are hard to pan without shaking; and second, their long barrels show in the view of shorter lenses on the same turret.

Most stations get along with some combination of the above six lenses. A few have had to obtain special in-between sizes to meet particular conditions—i.e., where the lens they would like to use is not quite wide enough, the next size too wide. Which of the two, or three, cameras will get which lenses depends on so many factors that it's impossible to generalize. To some extent it depends on the feeling of the director. Fortunately, lenses are easily interchanged so that the final choice does not have to be made until after the cameras are installed.

The six pictures on the opposite page show the field of view with the six sizes of lenses. These pictures, made from the

monitor screen (of WPTZ transmissions) show the view from two different camera locations (noted in captions). It is important for the neophyte to note that the camera location makes a great difference in the size of the field obtained with any particular lens size. In planning a new installation it is not safe to simply copy the lens sizes used in some other park. Instead, two scale drawings (one an elevation and one a plan) of the park should be made and the proposed camera locations accurately plotted. Then from each camera location the angle which the various lenses will give should be tested. A series of triangles cut from cardboard, with the correct angle for each lens, can be used for the purpose. The horizontal and vertical angles for the six standard lenses are:

Lens	Horizontal Angle	Vertical Angle
50mm	34°	25.5°
90mm	19°	14°
135mm	13°	10°
8½"	8°	6°
13½"	5°	3.7°
17"	4°	3°

If this system of pre-plotting angles is followed many disappointments can be avoided.

The Zoomar Question

At least nine stations (WAVE-TV, WBAP-TV, WBKB, WCOP-TV, WLW-D, WLW-T, WPIX, WTMJ-TV, KGO-TV) are using Zoomar lenses for baseball telecasting. It's not a majority, but is a large enough vote to make desirable a consideration of Zoomar possibilities.

The adjustable feature of the Zoomar lens makes it possible, when using this lens, to have a field view of any size from that of a 13" lens to that of a 90mm lens, approximately. Thus a camera with this lens can do anything a camera equipped with the four standard lenses (90mm, 135mm, 8½", 13") can do. A graphic illustration of this is afforded by a comparison of the pictures on Page 14 with those on Page 32. But the Zoomar has the additional advantage that it can change smoothly and almost instantaneously from one field angle to another. This means that the director can have a wide angle for his cover shot, change to a medium angle as he follows the ball on a hit, and then change to a narrow angle for a closeup of the catch—all without switching cameras. The exponents of minimum camera switching find this just to the doctor's order. By eliminating, or reducing, the switching involved it not only reduces viewer confusion, but

also makes the cameraman's and director's job much easier. The monitor screen pictures of switching sequences on Pages 36 to 38 illustrate this.

Balanced against the Zoomar's advantages are a number of disadvantages. The Zoomar is expensive itself—and it ties up one camera because it cannot be mounted on a standard turret, but rather requires a special attachment. It has more aberration than standard lenses—so that there is some loss of detail, particularly around the edges. And, finally, its light transmission factor is relatively low, so that most stations find they cannot use it for night games. (Although the new camera tubes may overcome this.)

After watching the Zoomar in action our feeling is that it is definitely a help in making a smooth presentation—and that the less experienced the crew, the more help it will be. However, there is still insufficient experience or evidence on which to base a definite prediction of the eventual extent of its use.

Control Facilities

At the start, most stations treat their baseball pickups as just another remote. Thus they run their mobile unit out to the park, pull their cables in, set up their cameras, work the game, dismantle everything and return to the studio. Doing this every day is a job—as they soon find out. Pulling the cables is ordinarily the worst part—so the evolution of a more or less permanent setup usually begins when someone gets the bright idea of buying some spare cables, so that those used at the ball park can be left in place for the season. Next comes permanent installation of audio lines and microphone positions, followed by announcer's monitoring facilities and so on. The final culmination is the achievement of a permanent control room position in, or under, the stands. Some half dozen stations—including the three in New York and the Philadelphia trio (one setup) have such an arrangement (Fig. 21). Where the station has enough equipment to leave most of it in place (at least during the home stand of the local team) this saves untold man-hours otherwise spent in hefting equipment around, testing out lines, etc.

Most stations, however, do not have such a luxury of equipment. And the feeling seems to be that if equipment must be taken back and forth each day—then it is better to have the control position in the mobile unit (Fig. 20), so that at least the camera controls, monitor, etc., do not have to be hoisted back and forth. Per-

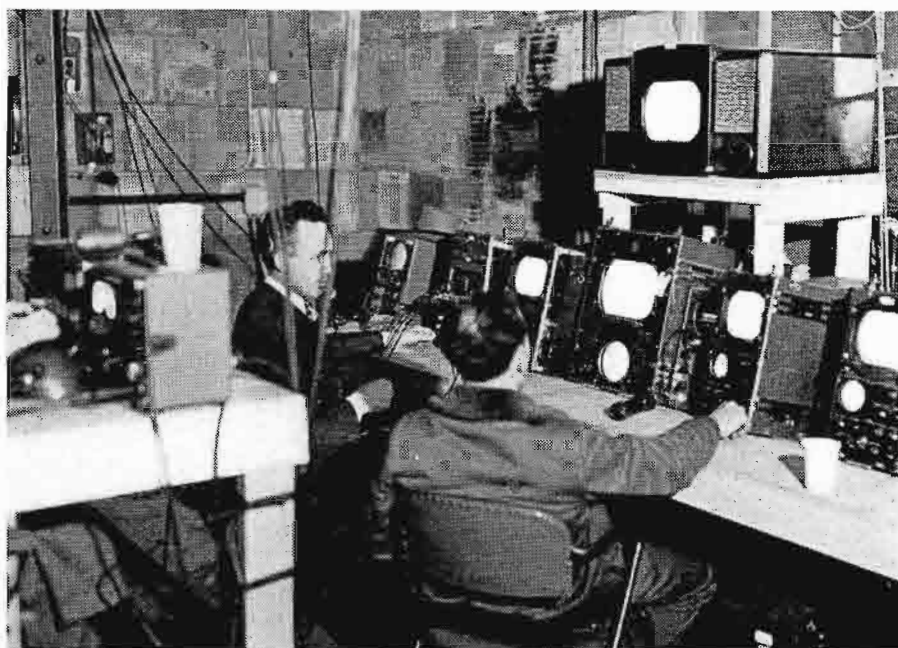
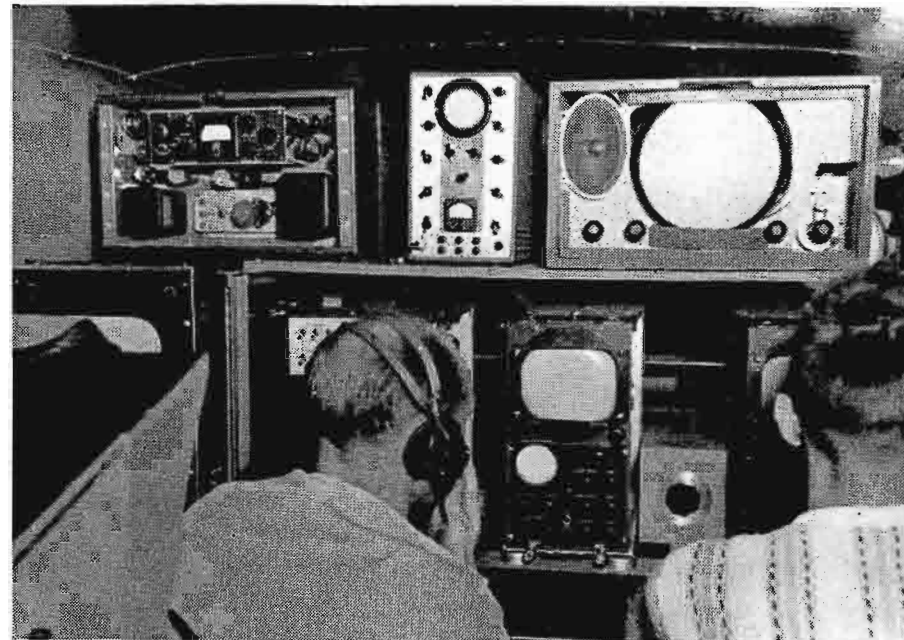

CAMERA CONTROL POSITIONS

FIG. 19 (above, left). RCA camera control and monitoring equipment is used by great majority of stations televising baseball. Three units at left are camera control units (one for each camera), next unit is camera switching unit. Large unit at right is master monitor.

FIG. 20 (above, right). KING-TV (formerly KRSC-TV), like most stations telecasting baseball, has its control equipment mounted in mobile unit. Small box on lower shelf is Selsyn controlling focus on camera (see Fig. 23, Page 18).

FIG. 21 (left). A number of the larger stations have semi-permanent control rooms located in the stands—like this one of WCBS-TV at Ebbetts Field, Brooklyn.

manent video cables and audio lines may still be used, so that the heavy work to be done every day is limited to carrying the cameras to their positions and making connections. Most of the stations operate this way today—with the mobile unit located anywhere from 75 feet to 500 feet from the cameras.

Camera Switching

It would be going too far to say that there is today complete agreement among directors on camera switching sequences for standard plays. However, directors are fairly well agreed on the principles of good camera switching—and such differences in technique as do occur are largely due to limitations imposed by less-than-perfect camera locations.

The guiding principle which has gradually emerged might be stated as “keep the camera on the ball.” There are exceptions, of course, but in general it has been found that the viewer can follow the game much easier if he can see the ball (or at least knows definitely where it is) all the time, and does not have to depend on the announcer to tell him where it is going. Thus, on a base hit (whether infield or

outfield), either the whole play must be covered by one camera or else the direction the ball is going (and to what fielder) must be clearly shown before switch is made to another camera for a closeup of the catch. This is called “keeping the viewer oriented.” The need for orientation, plus the fact that the interest is nearly always where the ball is (there are a few exceptions), greatly limits the director’s choice of shots.

The commonest play in baseball is a grounder to the infield. The camera coverage of such a play has been pretty well routinized. Charted, it goes like Chart No. 1.

In two-camera setups (not using Zoomar) little variation of this routine is practical. The opening shot may be with an $8\frac{1}{2}$ ” lens (thus showing catcher, and umpire, as well as batter), an occasional closeup of the pitcher may be thrown in (it takes good switching), or the final picture may be a closer view with a $13\frac{1}{2}$ ” or 17” lens. These, however, are very minor variations of the general routine.

When three cameras are used, an extra switch may be employed to show a closeup

of the fielder. The chart then reads like Chart No. 2.

The advantage of this extra shot is that it shows the shortstop closeup. Baseball addicts like it. Less dyed-in-the-wool fans, however, are apt to become confused by the very rapid switching (three cameras in three seconds, approximately) required. Generally, only a few stations use it.

When a Zoomar lens is employed, another variation occurs. Charted, it looks like Chart No. 3.

This sequence has the advantage of the previous one (i.e., closeup of shortstop) without the disadvantage of the rapid camera switch. In fact, the director can, and often does, use the Zoomar all the way—including the final closeup at 1st. By so doing he eliminates all switching during play. However, on plays from deep short or 3rd, the cameraman has to make too fast a pan with the throw. Hence, this latter variation is generally used only on short throws—from pitcher or 2nd baseman to 1st, short to 2nd, etc.

Despite the small differences in the three switching sequences outlined above, it is

apparent that they all follow the same pattern. They all open with a "cover" shot showing the pitcher-batter-catcher-umpire area, they all "follow-the-ball," and they all end with a closeup. A major variation in this sequence occurs when, because of a lack of a camera location behind home-plate, or for other reasons, the standard "cover" shot does not include both pitcher and batter (see Fig. 6). In this case the sequence opens with the same closeup of the batter taking his place at the plate—but then switches to a medium closeup of the pitcher winding up and throwing. While the ball is on its way to the plate switch is made to the other camera for a medium shot of the batter swinging. If he hits the ball, the sequence goes on from there in the standard order. The continual switching, from pitcher to batter and back again, on every throw is distracting. On the other hand, to "sit" on the batter leaves the viewer in suspense as the pitcher goes through his usual routine. Either way, it's not the ideal setup.

The second most common play in baseball is a fly ball to the outfield. Here the camera handling is even more fixed than on an infield play. Almost always it goes like Chart No. 4.

About the only variations on this sequence are in last shot—i.e., following the ball back in. Some do it with the No. 2 Camera. If three cameras are used, the third may be brought in at this point. If a Zoomar lens is used, it is customary to zoom in with it for a medium closeup of the outfielder catching the ball—rather than switching to No. 2 Camera.

So much for the camera handling when there are no baserunners. If there are runners on base when the batter comes up, the situation becomes more complicated—and the switching less routine. However, it must be remembered that most plays happen so fast that the director does not, as a rule, have time to tell his cameras where to go. Rather, he has to depend either on their judgment or on preset instructions. For instance, in the commonest situation—that of a man on 1st—Camera No. 2 usually is pre-instructed to "follow the runner." Thus, he is ready to provide a closeup of a play at 2nd—either on a steal or an infield hit. In this case, No. 1 follows the ball only until the infielder throws it to 2nd (if he does), after which No. 1 switches to 1st for a closeup of the second part of a possible double play. When only two cameras are used, such preset routines are absolutely necessary if the whole play is to be covered. With three cameras, it obviously is easier. In this case, No. 1 and No. 2 operate exactly as if there

CHART NO. 1

Infield Play (No Baserunners) with Two Cameras

Action	Camera	Lens	Viewer Sees
Batter walking up to plate	#2	17"	Closeup of batter
Pitcher delivers	#1	135mm	Pitcher-batter-catcher-umpire
Batter hits grounder toward shortstop	#1	135mm	Center of infield as camera pans with ball
Shortstop makes catch, throws to 1st	#1	135mm	Center of infield as camera continues to "follow-the-ball"
1st baseman catches ball, runner crosses bag	#2	8½"	1st base area in a medium closeup

CHART NO. 2

Infield Play (No Baserunners) with Three Cameras

Action	Camera	Lens	Viewer Sees
Batter walking up to plate	#2	13½"	Closeup of batter
Pitcher delivers	#1	135mm	Pitcher-batter-catcher-umpire
Batter hits grounder toward shortstop	#1	135mm	Center of infield as camera pans with ball
Shortstop makes catch, throws to 1st	#3	8½"	Medium closeup of shortstop making play
1st baseman catches ball, runner crosses bag	#2	13½"	Closeup of 1st base area

CHART NO. 3

Infield Play (No Baserunners) with Zoomar Lens

Action	Camera	Lens	Viewer Sees
Batter walking up to plate	#2	17"	Closeup of batter
Pitcher delivers	#1	Zoomar—Out (wide angle)	Pitcher-batter-catcher-umpire
Batter hits grounder toward shortstop	#1	Zoomar—Medium (medium angle)	Medium closeup of infield as camera pans with ball
Shortstop makes catch, throws to 1st	#1	Zoomar—In (narrow angle)	Closeup of shortstop
1st baseman catches ball, runner crosses bag	#2	13½"	Closeup of 1st base area

CHART NO. 4

Outfield Play (No Baserunners) with Two Cameras

Action	Camera	Lens	Viewer Sees
Batter walking up to plate	#2	17"	Closeup of batter
Pitcher delivers	#1	135mm	Pitcher-batter-catcher-umpire
Batter hits to leftfield	#1	135mm	General leftfield direction as camera "follows the ball"
Leftfielder makes catch and throws in	#2	17"	Closeup of leftfielder
Ball returned to infield	#1	135mm	Infield area ending with standard "cover" shot



FIG. 22 (left, above). One arrangement for originating commercials at the park is illustrated by this WPTZ setup at Shibe Park, Philadelphia. Charts, arranged for easy turning, are mounted on an easel near the No. 2 Camera, which can be focused on this as announcer sitting at table reads continuity. Note monitor mounted on table does not obstruct announcer's view of field.

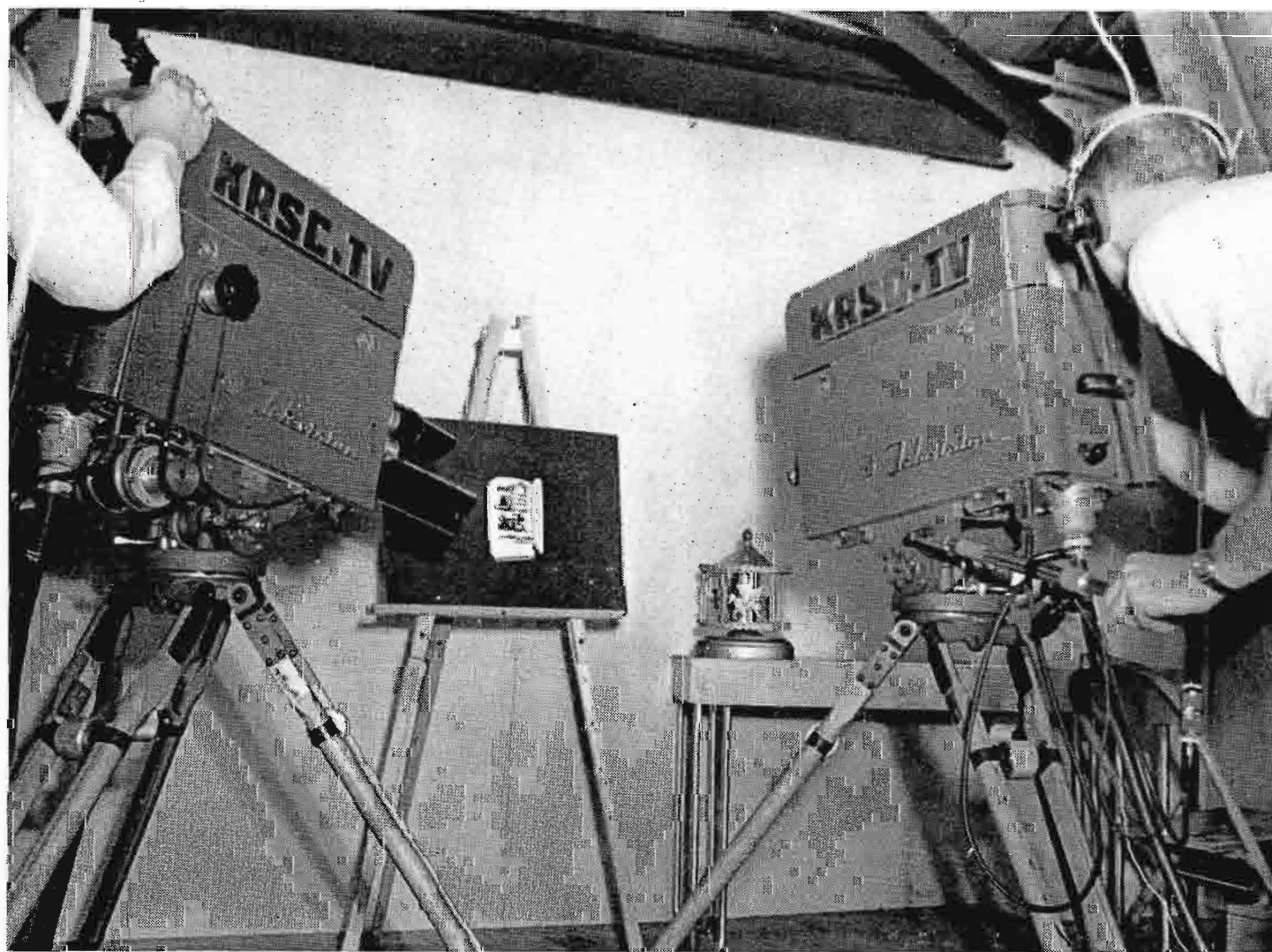

FIG. 23 (left, below). KING-TV (formerly KRSC-TV) produces commercials in the rear of its booth, as shown here—cameras simply swinging around 180° from their normal position. Note Selsyn unit, on left-hand camera, for controlling camera focus (from control position).

means he must provide a setup which will allow the film studio facilities, and the facilities of at least one live studio, to be used for commercial breaks during the game.

Unfortunately, the necessity of switching back to the studio for commercials increases personnel problems and ties up facilities which may be needed for rehearsals. Also, it introduces cueing requirements which decrease flexibility. As a result many stations have tried out various stratagems designed to make it possible to produce interesting commercials at the park. The simplest arrangement—until recently it was rather widely used—is an easel chart placed near one of the cameras (Fig. 22). During breaks between innings the camera is focused on the chart material which may be printed matter, photographs, cartoons, a scoreboard with sponsor's identification, or what have you. A more subtle method is the one used by WPIX and illustrated on Page 39. A huge Chesterfield sign in centerfield is played up—and the announcer shown smoking a Chesterfield (we hope). In order to make this really effective Chesterfield persuaded the Giants to remove all other signs from the park.

KING-TV (formerly KRSC-TV) uses an ingenious arrangement for presenting their product "live." Their camera booth was built special and was made large and very deep. In the space behind the cameras (Fig. 23) there is a table for an announcer, room for product displays, small backdrops, etc. Between innings they simply swing their cameras around and they're set for any kind of commercial the sponsor desires. WCBS-TV carries this idea one step further. They have an actual studio in a room next to the Press Club Room. Their No. 4 Camera is located in this studio. The camera control unit for this camera is located with the others in the adjacent control room (Fig. 21). The "live" commercial for Schaefer's Beer, which is produced here, is one of the best. This and the animated jingles (film strip) for Balantine's Ale (WABD, WPTZ, et al.) will hold their own with any TV commercials.

were no runner—while No. 3 sets up for the play at 2nd.

The really difficult moment of decision for the director is the situation which occurs when there is a long safe hit to the outfield with runners on base. The question is whether to follow the ball or the runners, especially if the latter are likely to score. This is the "exception" mentioned above. Most directors, having shown the viewer where the ball is going, will switch to the most advanced runner. However, if the switch is too quick there is a long moment of suspense while the viewer, watching the runner heading for the plate, waits for the ball to again come in view.

Commercials

Until quite recently the commercials on nearly all TV sports programs were rather ineffectively handled. Slides or charts were the usual medium—and it seems strange how long it took the commercial people to wake up to the fact that the best slides have a deadness which is especially noticeable when interjected between the action-packed stanzas of a good sports event.

Anyway, day finally dawned and our survey indicates most stations are now using films and "live" product spots—if not in place of slides, at least in addition to them. This is a development the planning engineer must keep in mind—for it

WBKB CHICAGO

Games: Chicago Cubs (National League).

From: Wrigley Field, Chicago.

Cameras: Three RCA TK-30A.

Cameras Located: No. 1 at ground level next to Cubs dugout (70 feet from plate). No. 2 and No. 3 together midway between homeplate and outfield wall and about 30 feet high.

WBZ-TV BOSTON

Games: Braves, Red Sox (National, American Leagues).

From: Braves Field, Fenway Park, Boston.

Cameras: Two RCA TK-30A.

Cameras Located: No. 1 in booth below press box, about 100 feet from plate and 40 feet high. No. 2, also in booth, on first base side of homeplate.

KSTP-TV ST. PAUL

Games: Minneapolis (American Association).

From: Nicollet Park, Minneapolis.

Cameras: Three RCA TK-30A.

Cameras Located: No. 1 and No. 2 on grandstand roof opposite 1st base. No. 3 (unattended) looks through small hole in fence behind catcher at shoulder level.

WLW-C COLUMBUS

Games: Columbus Red Birds (American Association).

From: Columbus.

Cameras: Three RCA TK-30A.

Cameras Located: No. 1 on roof of grandstand, 60 feet from plate, 40 feet high and 40 feet toward 3rd base. No. 2 in upper tier opposite 1st base (30 feet high, 125 feet from 1st base).

WLW-D DAYTON

Games: Dayton Indians (Central League).

From: Hudson Field, Dayton.

Cameras: Two RCA TK-30A.

Cameras Located: No. 1 directly behind homeplate on grandstand roof (60 feet away from home, 40 feet high). No. 2 also on roof about 30 feet to right of No. 1.

WGN-TV CHICAGO

Games: White Sox (American League).

From: Comisky Park, Chicago.

Cameras: Three RCA TK-30A.

Cameras Located: No. 1 and No. 2 behind homeplate, medium height. No. 1 in first row box next to the 1st base dugout.

WCAU-TV PHILADELPHIA

Games: Athletics, Phillies (American, National Leagues).

From: Shibe Park, Philadelphia.

Cameras: Two RCA TK-30A.

Cameras Located: WFIL-TV, WCAU-TV and WPTZ rotate Philadelphia games. WPTZ crew makes all pickups—see Page 20 for camera locations.

WFIL-TV PHILADELPHIA

Games: Athletics, Phillies (American, National Leagues).

From: Shibe Park, Philadelphia.

Cameras: Two RCA TK-30A.

Cameras Located: WCAU-TV, WFIL-TV and WPTZ rotate Philadelphia games. WPTZ crew makes all pickups—see Page 20 for camera locations.

WTCN-TV MINNEAPOLIS

Games: St. Paul Saints (American Association).

From: Lexington Park, St. Paul.

Cameras: Two RCA TK-30A.

Cameras Located: No. 1 and No. 2 located on the roof of the grandstand at Lexington Park.

WSPD-TV TOLEDO

Games: Toledo (American Association).

From: Toledo, Ohio.

Cameras: Two RCA TK-30A.

Cameras Located: No. 1 and No. 2 along 1st base line, medium height.

WPTZ PHILADELPHIA

Games: Athletics, Phillies (American, National Leagues).

From: Shibe Park, Philadelphia.

Cameras: Two RCA TK-30A.

Cameras Located: No. 1 behind homeplate about 20 feet high. No. 2 slightly to right of homeplate about 80 feet high.

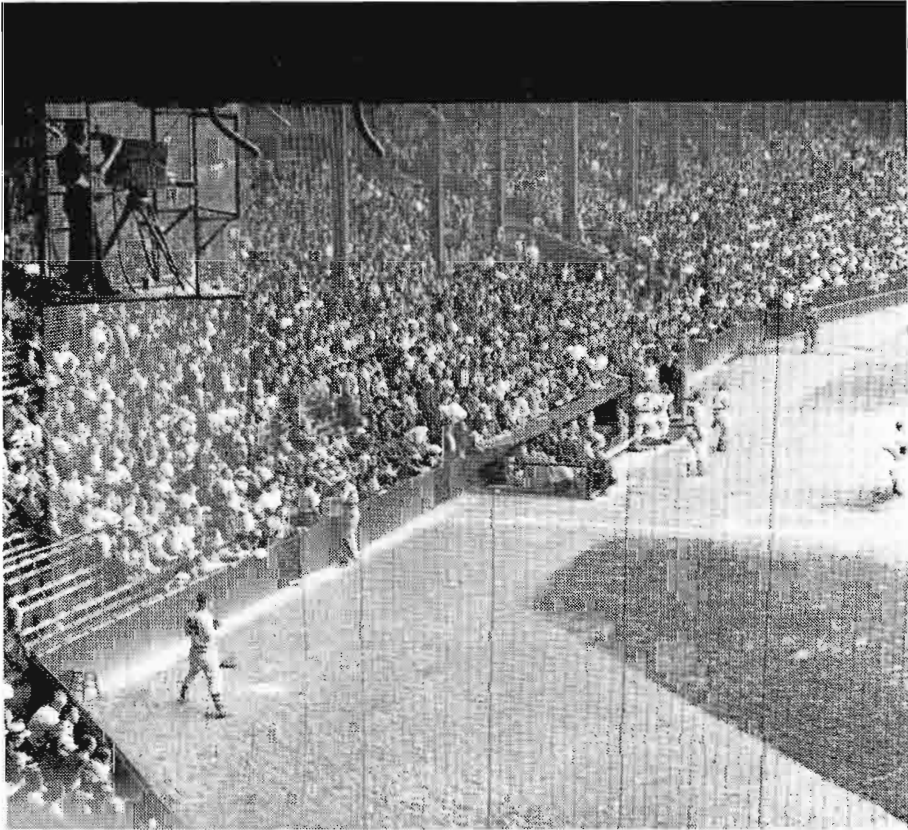

WPTZ's No. 1 Camera, in cage (plexi-glass front) hung beneath second tier directly behind homeplate, provides ideal "cover" shot (see picture on Page 11).



WPTZ's No. 2 Camera in press box behind plate (very slightly to right) provides good view of outfield, picture of announcer, and chart easel (see Page 18).

WCBS-TV NEW YORK

Games: Brooklyn Dodgers (National League).

From: Ebbets Field, Brooklyn.

Cameras: Four RCA TK-30A.

Cameras Located: No. 1 and No. 2 behind plate, 25 feet high, 60 feet away from plate. No. 3 on 3rd base side, 25 feet high, 70 feet away from plate. No. 4 (for commercials) in studio adjacent to Press Room.

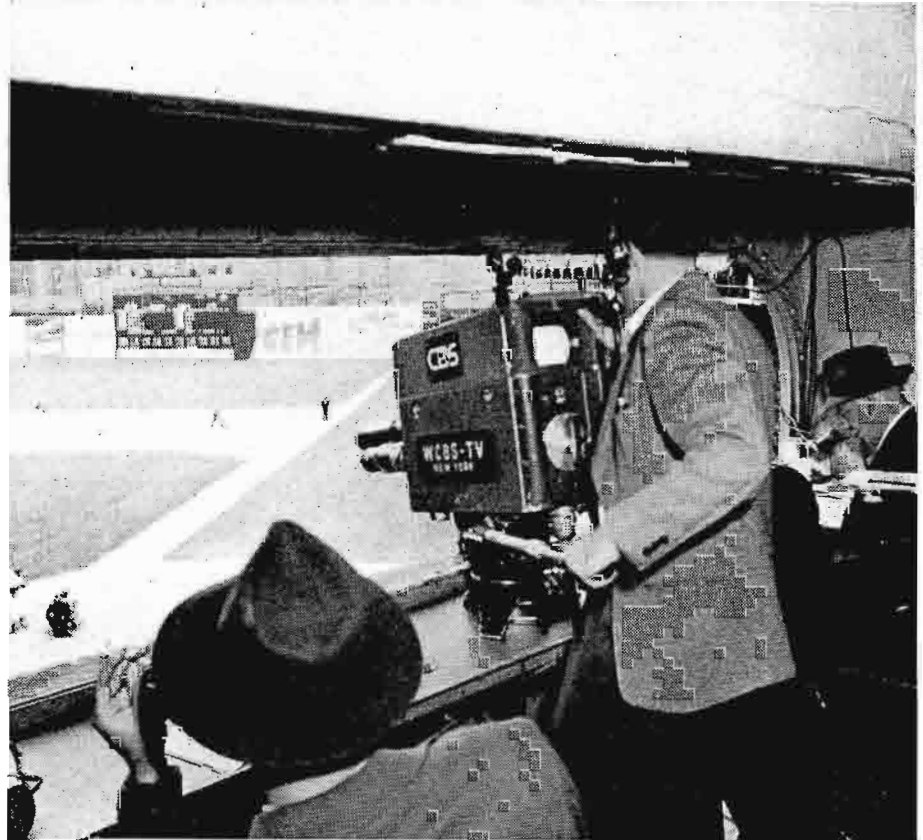

WCBS-TV's No. 1 and No. 2 Cameras are ideally located in booth directly behind homeplate. Position is low enough for good "cover" shot with relatively small-size lens.

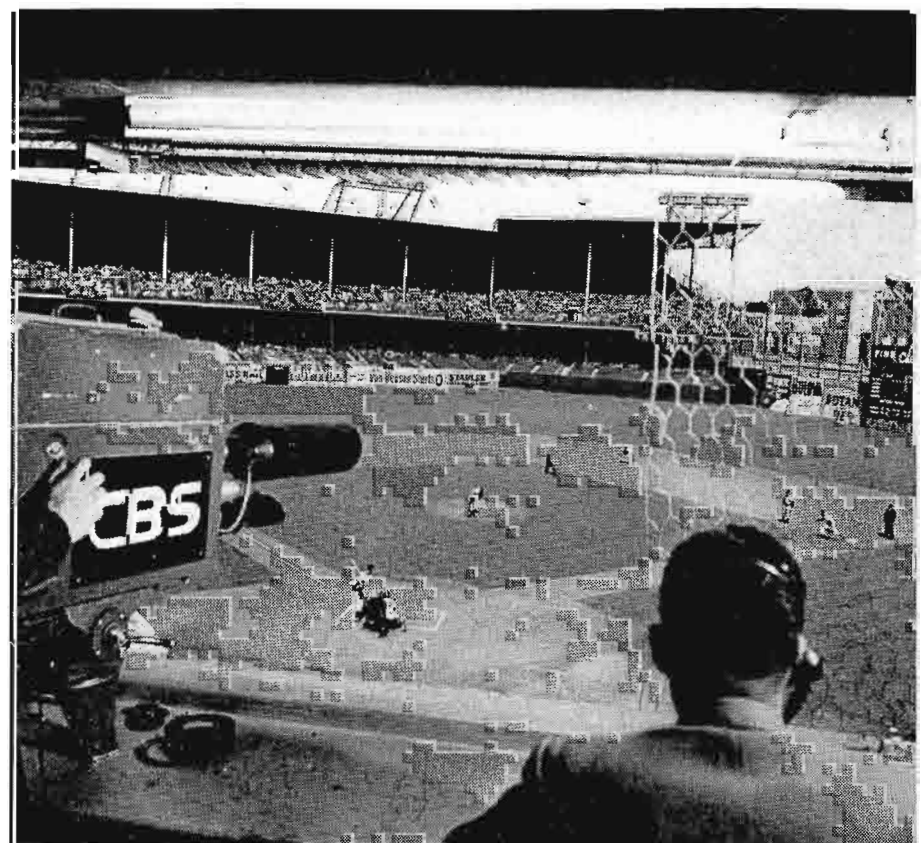

WCBS-TV's No. 3 Camera in similar booth to left of No. 1 and approximately in line with 1st base and homeplate. Used for out-field plays, closeup at plate, etc.

WABD NEW YORK

Games: Yankees (American League).

From: Yankee Stadium, New York.

Cameras: Three Dumont Mark II.

Cameras Located: No. 1 in cage hanging from top balcony, directly behind homeplate, 60 feet high, 60 feet from plate. No. 2 and No. 3 about 40 feet high, 70 feet from homeplate, and 10 to 15 feet toward 1st base.

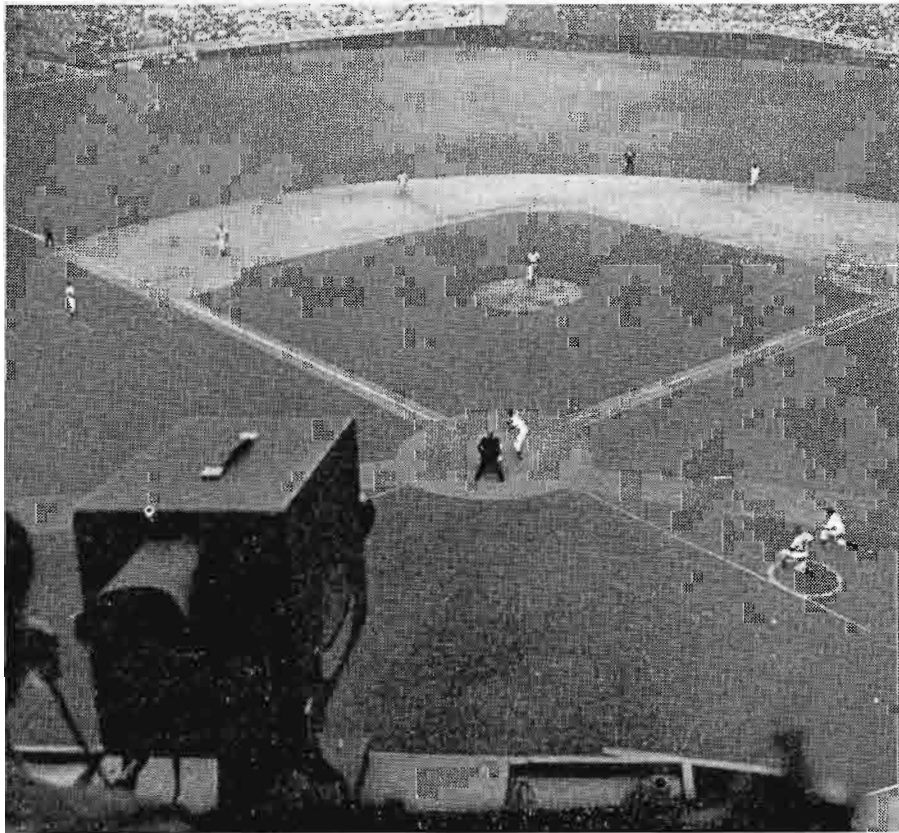

WABD's No. 1 Camera in 60 feet high cage hung from top balcony. Gives good picture of outfield and makes it possible to pick up announcer (simultaneous radio and TV) reading commercial.



WABD's No. 2 and No. 3 Cameras are 40 feet high just a little to right of pitcher-batter line. Locating all three cameras at same horizontal helps orientation on fast camera switches.

WTTG WASHINGTON

Games: Senators (American League).

From: Griffith Stadium, Washington.

Cameras: Three Dumont Mark II.

Cameras Located: No. 1 in box suspended from first tier opposite 1st base, 102 feet from homeplate and 29 feet high. No. 2 and No. 3 in box suspended from first tier behind homeplate, 75 feet from plate and 27 feet high.

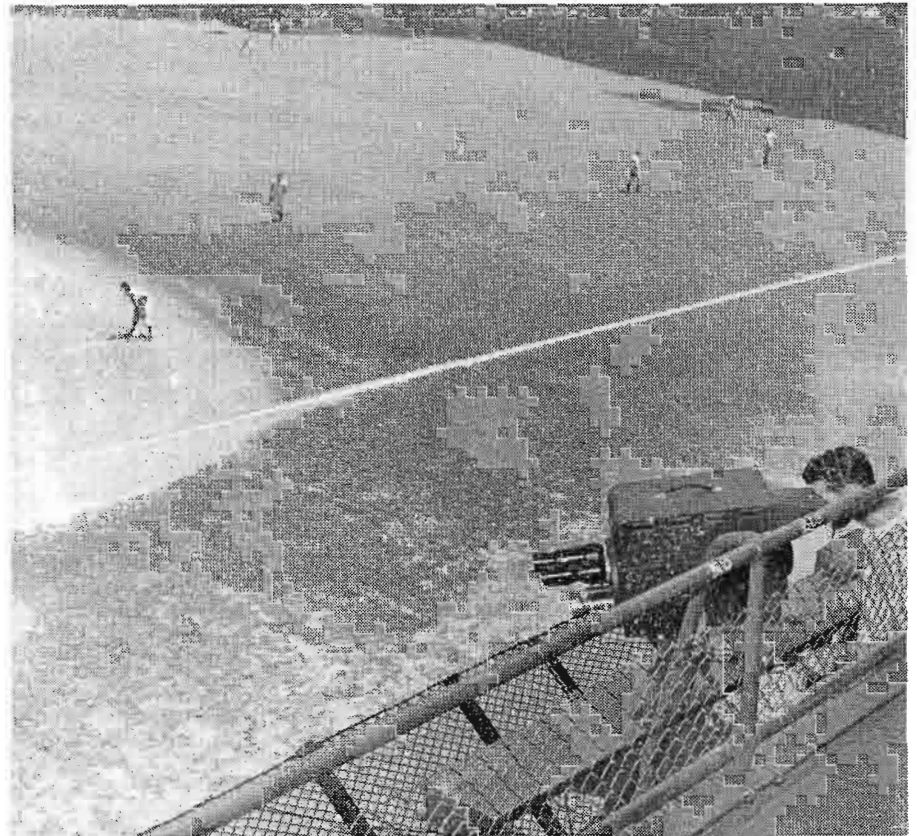

WTTG's No. 1 Camera in box suspended from first tier opposite 1st base provides very good coverage on 1st base and outfield shots, closeups of 1st baseman, pitcher, etc.

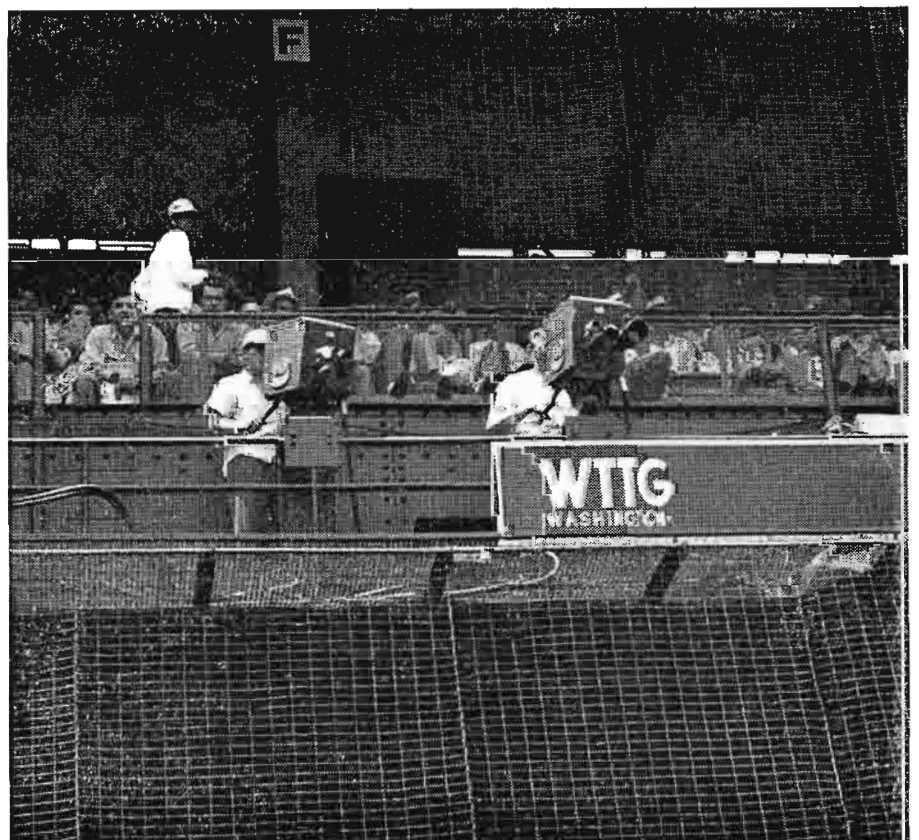

WTTG's No. 2 and No. 3 Cameras are ideally located directly behind homeplate in box suspended from the first tier. This position assures ideal cover shot (see picture on Page 11).

KSD-TV ST. LOUIS

Games: Cardinals, Browns (National and American Leagues).

From: Sportsman's Park, St. Louis.

Cameras: Two RCA TK-30A.

Cameras Located: Both No. 1 and No. 2 in box below upper tier on 1st base side, about 35 feet high and 85 feet from plate.

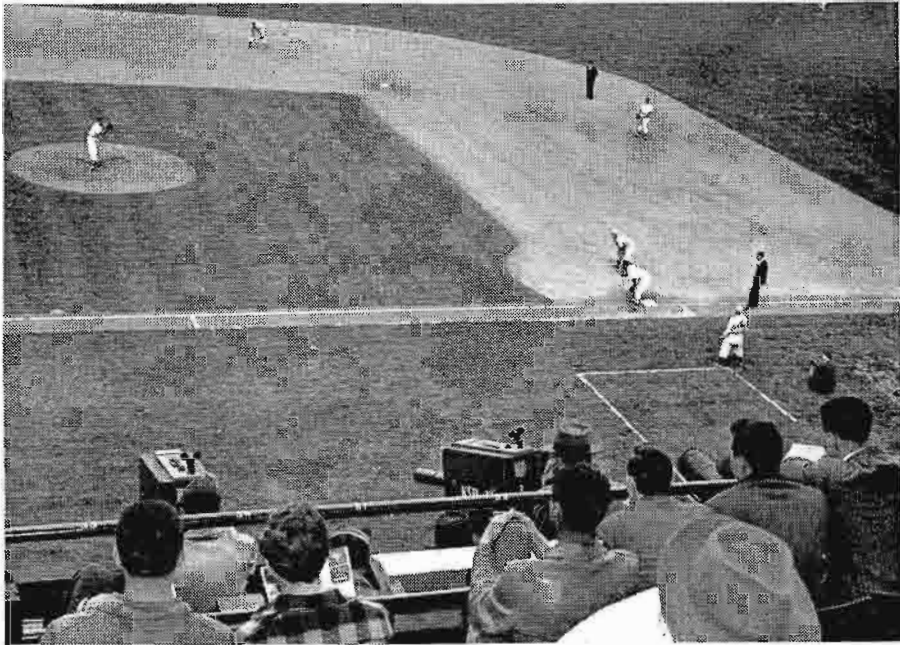

KSD-TV's two cameras are located along the 1st base line about midway between homeplate and 1st base "as nearly as possible in the most sought after seats in the park."



This shows how the special booth was built out from the second tier to provide KSD-TV with its vantage point. All cables and audio facilities are installed permanently to facilitate setup.

WWJ-TV DETROIT

Games: Detroit Tigers (American League).

From: Briggs Stadium, Detroit.

Cameras: Three RCA TK-30A.

Cameras Located: No. 1 directly behind homeplate in 2nd deck (55 feet high). No. 2 in room hung below 2nd deck about 50 feet toward 1st base. No. 3 in similar room 50 feet toward 3rd base.

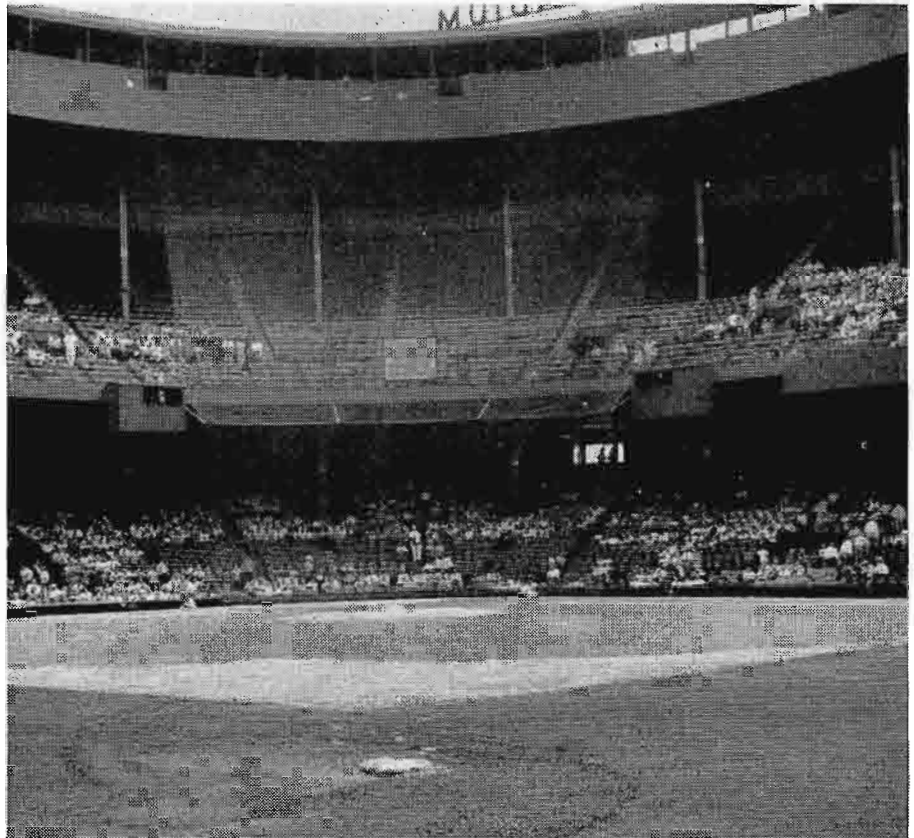

WWJ-TV's three camera locations can be seen in this picture. No. 1 is in the plexi-glass front booth in center of second tier. No. 2 and No. 3 are in booths which are hung below second tier about 50 feet to left and right, respectively, of center booth.



This is the view from the behind-the-plate booth at Briggs Stadium. Two cameras are shown, but in present operation only No. 1 Camera is located at this point.

WAVE-TV LOUISVILLE

Games: Louisville Colonels (American Association).

From: Parkway Field, Louisville.

Cameras: Two RCA TK-30A.

Cameras Located: No. 1 in press box 35 feet high, 40 feet from plate and 15 feet to right of homeplate line. No. 2 same height, but on 1st base side looking down 3rd base line.

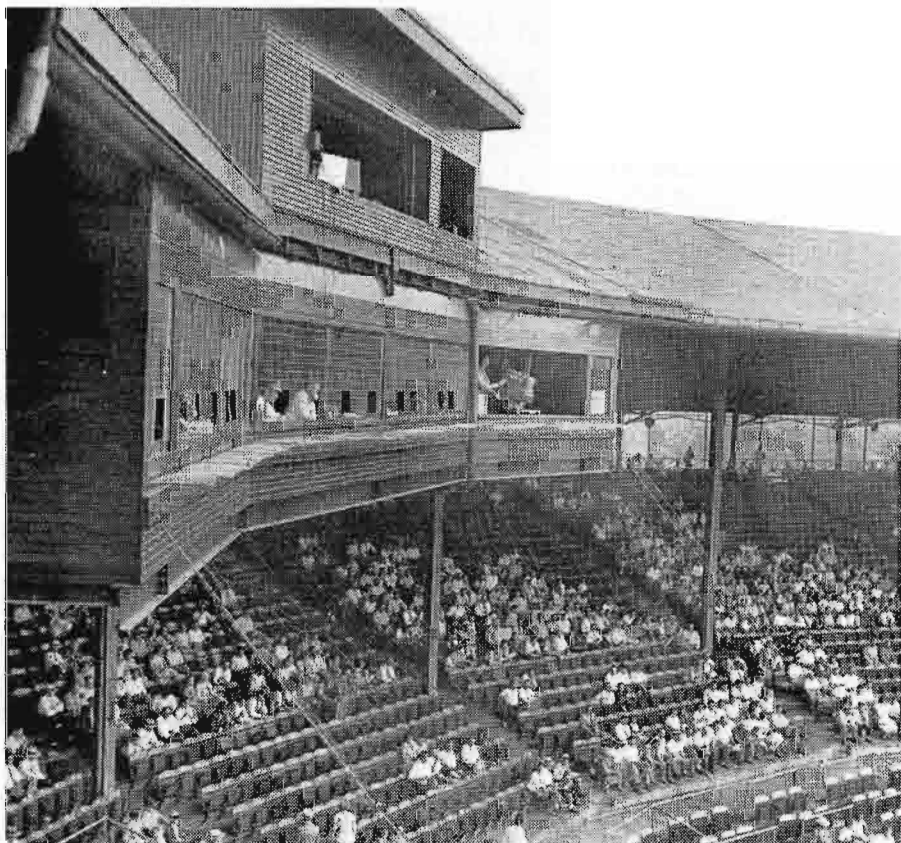

WAVE-TV's No. 1 Camera is located in 35 feet high press box shown here. Originally it was in booth on top of stand, but vertical angle proved too great for good "cover" shot.



WAVE-TV's No. 2 Camera is located on a special platform (left center in this picture) at same height as No. 1. A special 7" lens is used on No. 2 for closeups at night and a Zoomar for daytime use.

WLW-T CINCINNATI

Games: Cincinnati Reds (National League).

From: Crosley Field, Cincinnati.

Cameras: Three RCA TK-30A.

Cameras Located: No. 1 in upper grandstand behind homeplate and about 75 feet away. No. 2 and No. 3 together in a box midway between homeplate and 1st and about 40 feet high.

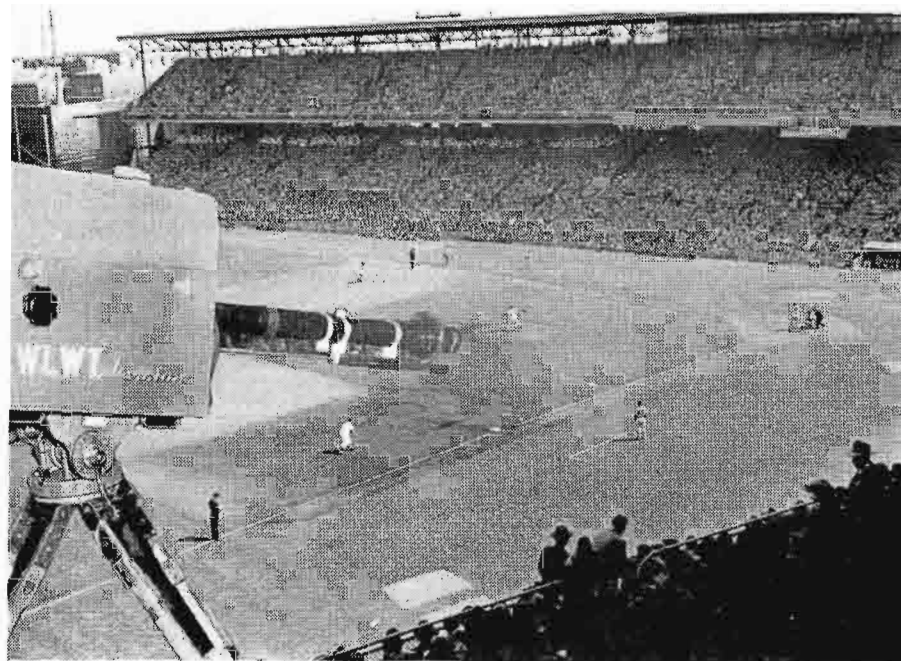

This is a composite (paste-up) picture. Actually WLW-T's No. 1 Camera with its Zoomar lens (daytime) is located in the upper grandstand directly behind homeplate.



WLW-T's No. 2 and No. 3 Cameras are set up in a box hung below the second tier—about midway between homeplate and 1st base. Camera No. 2 is used for closeups—and to "follow the batter." No. 3 for color shots.

KGO-TV SAN FRANCISCO

Games: Oakland Oaks (Pacific Coast League).

From: Oakland Ball Park, San Francisco.

Cameras: Three RCA TK-30A.

Cameras Located: No. 1 behind homeplate about 175 feet away. No. 2 and No. 3 between plate and 1st base, about two-thirds of distance to 1st base.

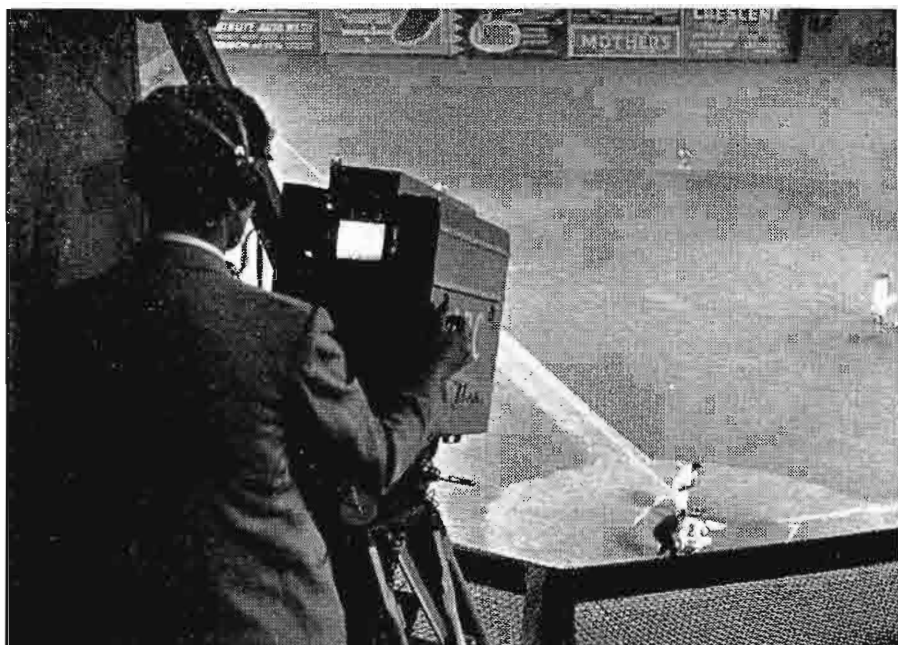

KGO-TV's No. 1 Camera, in a booth high behind homeplate, covers pitched ball—mound to plate—and follows the ball on a hit to show direction before switch to No. 2 or No. 3 to show catch.



KGO-TV's No. 2 and No. 3 Cameras are mounted in these specially-built booths along 1st base line. No. 2 covers infield play, No. 3 (using Zoomar lens daytimes) the outfield play.

KING-TV (Formerly KRSC-TV) SEATTLE

Games: Seattle Rainers (Pacific Coast League).

From: Sick's Stadium, Seattle.

Cameras: Two RCA TK-30A.

Cameras Located: Both cameras located in special booth under roof of grandstand, directly behind and approximately 85 feet from plate.



KING-TV's two cameras are located in a specially-built booth directly under the roof of the grandstand—about 85 feet from homeplate. (Another picture of this booth is shown on Page 18).

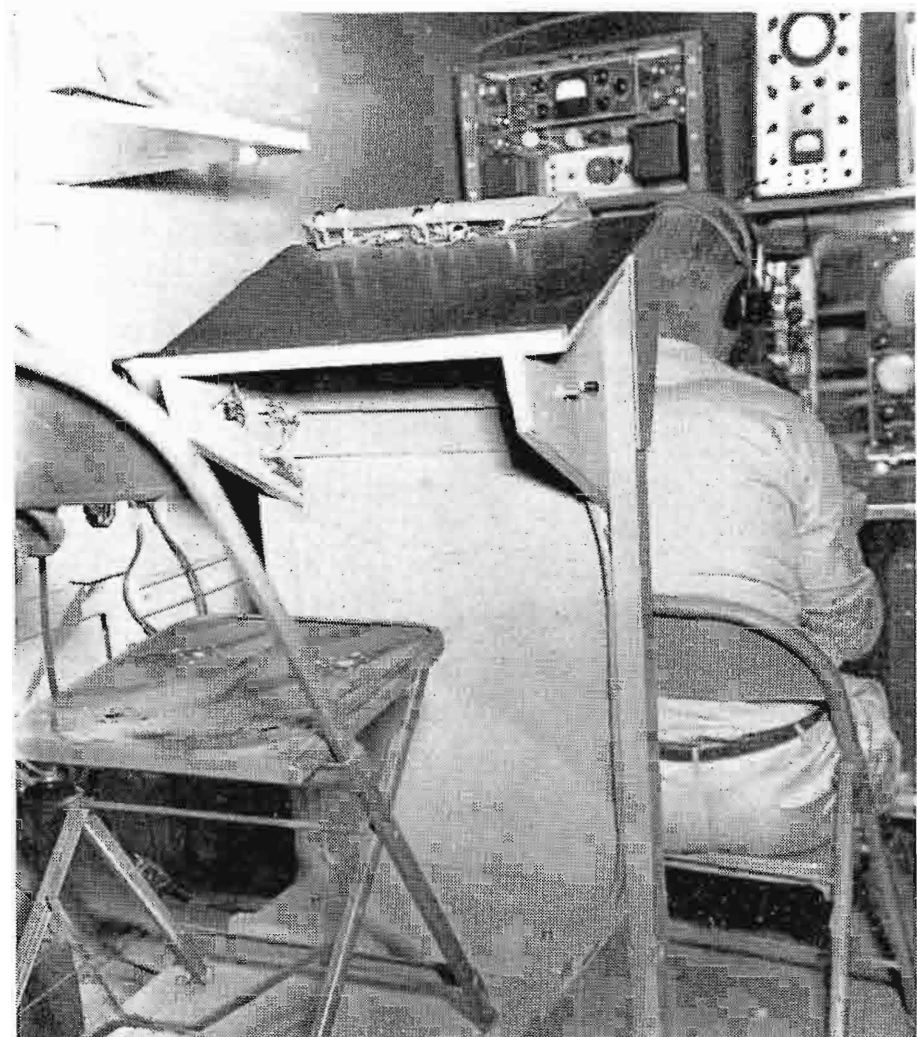

Unusual feature of the KING-TV mobile unit is a "producer's podium" (above) located directly behind camera control position. Note two buttons on floor of podium used for switching cameras. (Look Ma, no hands!)

WATV NEWARK

Games: Newark, Jersey City (International League).

From: Newark, Jersey City.

Cameras: Two RCA TK-30A.

Cameras Located: Both No. 1 and No. 2 on roof of grandstand, 75 feet high. No. 1 behind homeplate, No. 2 in line with 3rd base.



WATV's two cameras are located on the roof of the grandstand at Roosevelt Stadium, as shown above. Position, which is 75 feet high, gives unusually good view of the whole field.



WATV, like nearly all stations telecasting baseball, uses RCA Microwave equipment to relay video signal to studio or transmitter. In many cases roof of grandstand provides necessary height for transmitting parabola.

WTMJ-TV MILWAUKEE

Games: Milwaukee Brewers (American Association).

From: Borchert Field, Milwaukee.

Cameras: Two RCA TK-30A.

Cameras Located: No. 1 in roof booth directly behind homeplate, 35 feet high, 60 feet from plate. No. 2 same height, approximately 36 feet toward 1st base.

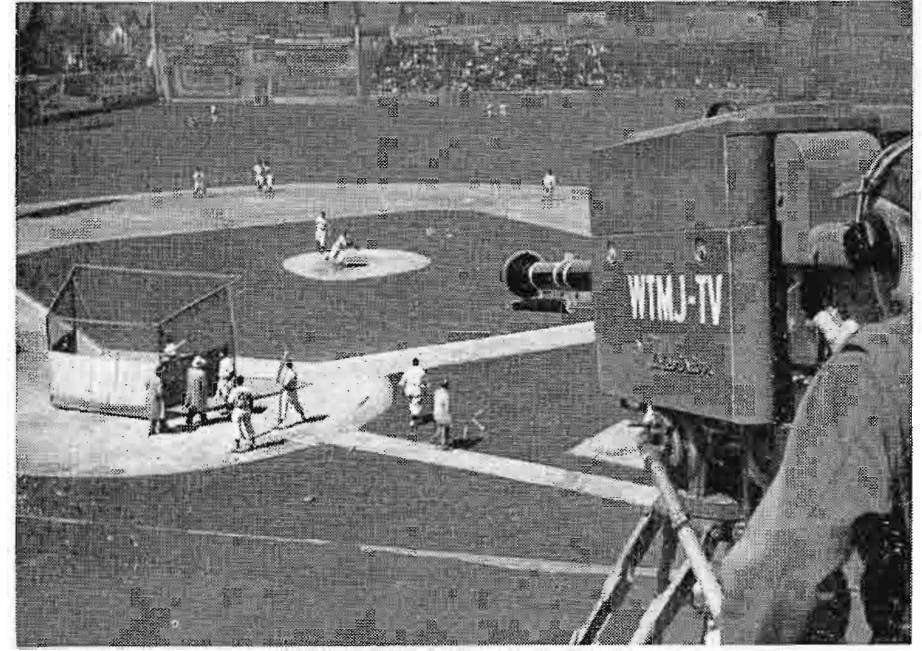

WTMJ-TV's No. 2 Camera, on roof of grandstand toward 1st base, uses a Zoomar daytimes (telephoto, night) to cover advanced runner on infield plays and to follow the ball on outfield plays.



WTMJ-TV's No. 1 Camera, in the plexi-glass enclosed booth on the roof of the grandstand, uses a wide-angle lens to cover ball on infield plays, advanced runner on outfield plays. Announcer is also located in this booth.

WEWS CLEVELAND

Games: Cleveland Indians (American League).

From: Municipal Stadium, Cleveland.

Cameras: Three Dumont.

Cameras Located: No. 1 behind homeplate about 100 feet away (and 20 feet high). No. 2 toward 1st base in upper stand, about 40 feet high. No. 3 opposite first base about 20 feet high.

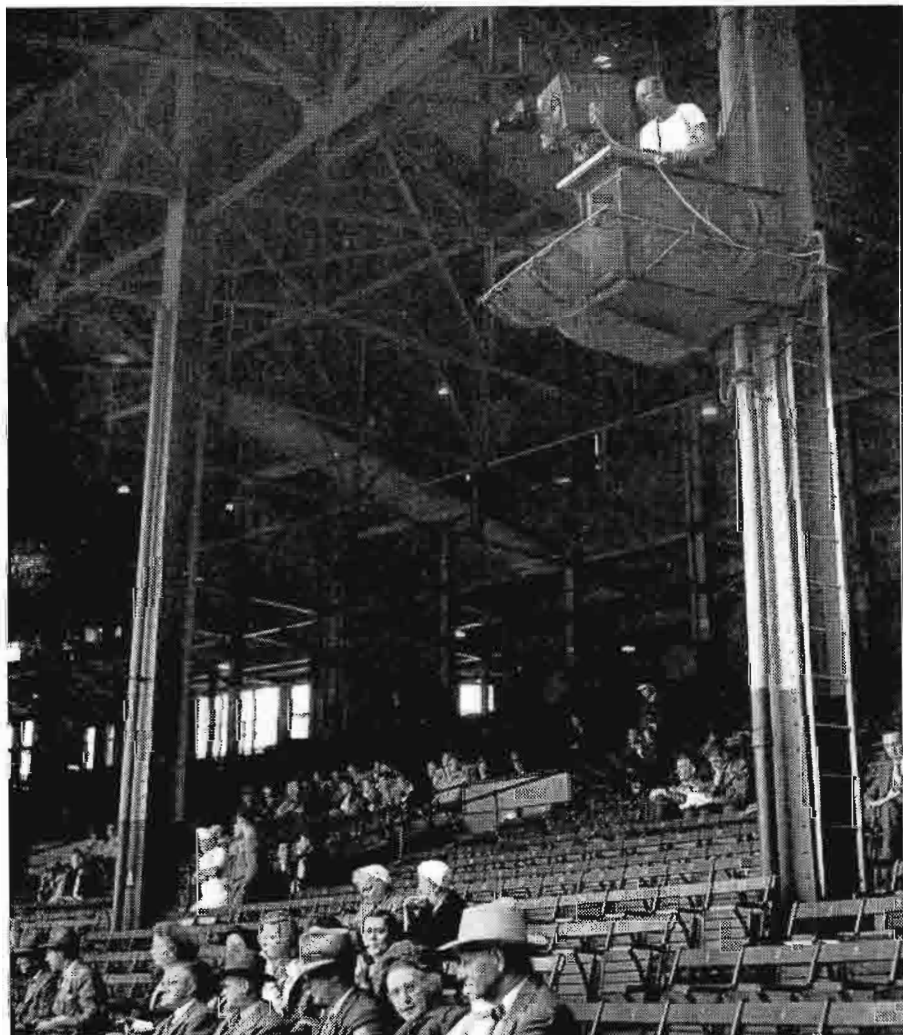

WEW's camera setup is unusual. No. 1 Camera (shown above) is located in a "crows nest" directly behind homeplate and about 20 feet high, which gives an ideal cover shot. No. 2 is in the second tier toward 1st base. No. 3 is mounted like No. 1 in the lower stands opposite 1st base. Latter is used with 25" lens for dugout interviews—thereby saving the work of moving a camera down to the field for this purpose. WEWS telecasts have been much acclaimed by reviewers.

WBAP-TV FT. WORTH

Games: Ft. Worth Cats (Texas League).

From: La Grave Field, Ft. Worth.

Cameras: Two RCA TK-30A.

Cameras Located: Both No. 1 and No. 2 on platform 25 feet high, slightly to right behind homeplate.



WBAP-TV's two cameras are located on a special platform, which is a good thing, for on May 14 a disastrous fire burned out the stands at the Cats' field, the flames coming within a foot of the camera platform. Picture above shows scene on following day. In rebuilding the stands the platform, shown opposite 3rd base, was moved to a position behind homeplate. WBAP-TV, like a number of others, uses a Zoomar on one camera for day games.

WCPO-TV CINCINNATI

Games: Cincinnati Reds (National League).

From: Crosley Field, Cincinnati.

Cameras: Two RCA TK-30A.

Cameras Located: No. 1 in upper grandstand behind homeplate and about 75 feet away. No. 2 on the rail at field level.

WTJV

Games: Miami Beach Flamingos (Florida-International League).

From: Flamingo Park, Miami Beach.

Cameras: Three Dumont 124-B.

Cameras Located: No. 1 atop 3rd base dugout, 8 feet high, 60 feet from homeplate. No. 2 and No. 3 on top of grandstand, 40 feet high, 20 feet left of homeplate.

WDSU-TV NEW ORLEANS

Games: American Legion Teams (Amateur).

From: Muny Park, New Orleans.

Cameras: Two RCA TK-30A.

Cameras Located: No. 1 behind plate, 12 feet high, 15 feet from plate (small park). No. 2 on top of grandstand above No. 1, about 20 feet high.



WDSU-TV telecasts American Legion League games (pro league not available) from Muny Park, which is relatively small. In order to get a good cover shot the camera had to be very low (12 feet above ground). The view from this location is shown above. It has the disadvantages of very low locations—but nobody can say it isn't an "umpire's eye view." Camera No. 2 (not shown) is on the roof of the stand (20 feet high) provides a better view of the outfield.

KLAC-TV LOS ANGELES

Games: Hollywood Stars, Los Angeles (Pacific Coast League).

From: Wrigley Field, Gilmore Field.

Cameras: Three RCA TK-30A.

Cameras Located: No. 1 behind plate, 5 feet high. No. 2 and No. 3 directly behind 1st base. (1st tier at Gilmore Field, 2nd tier at Wrigley Field.)



KLAC-TV's No. 1 Camera position is shown above. Here again the location is very low—only 5 feet off the ground. This has the disadvantage that players occasionally walk in front of it—but it gives an unusually dramatic picture of pitcher's delivery. It is even claimed that you can see the ball break on a curve. KLAC-TV's No. 2 Camera is higher—in the first tier at Hollywood, and in the second tier at Los Angeles. This is used for outfield shots.

KFMB-TV SAN DIEGO

Games: San Diego (Pacific Coast League).

From: San Diego.

Cameras: Two Dumont TA-124-B.

Cameras Located: No. 1 in box seats, 75 feet behind and slightly to right of homeplate. No. 2 on roof of grandstand opposite 1st base.

WNAC-TV BOSTON

Games: Red Sox, Braves (American, National Leagues).

From: Fenway Park, Braves Field, Boston.

Cameras: Three G.E.

Cameras Located: No. 1 behind homeplate in upper tier 50 feet high and 75 feet from homeplate. No. 2 to the right of homeplate. No. 3 opposite 1st base.

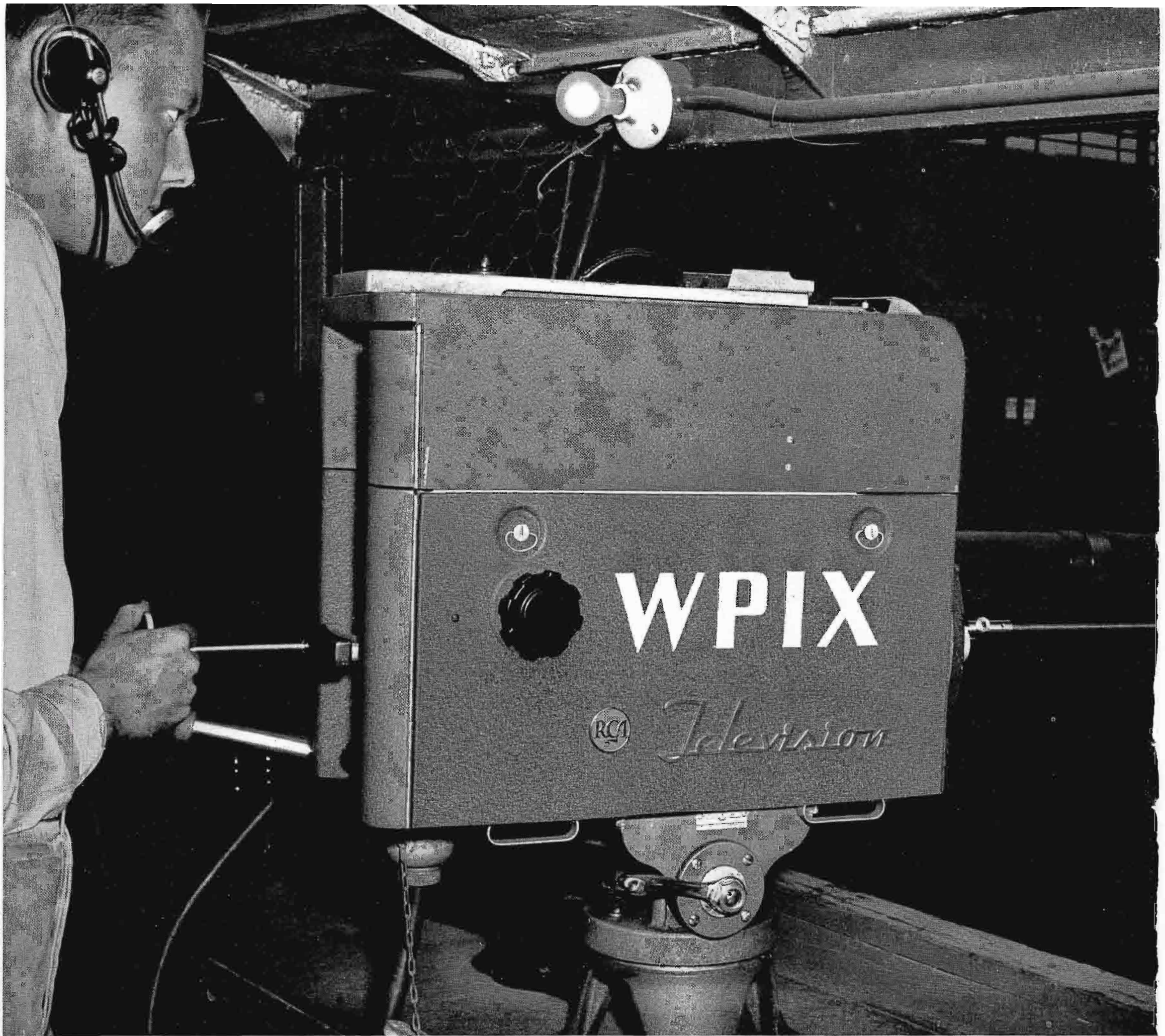

WPIX Baseball

HOW NEW YORK'S NO. 1 SPORTS STATION SETS UP ITS EQUIPMENT AND CONDUCTS OPERATIONS AT THE POLO GROUNDS — WITH PHOTOS FROM THE MONITOR SCREEN SHOWING FIELD OF VIEW WITH VARIOUS CAMERAS, EFFECT OF ZOOMAR LENS, AND TYPICAL CAMERA SWITCHING SEQUENCES

WPIX, the television station of the New York Daily News, has made a name for itself as the No. 1 sports station of New York. With boxing and wrestling from local arenas, trotting races from Roosevelt Raceway and telecasts of all the home games of the New York Giants from the Polo Grounds, it probably pre-

sents more hours of top sports for the local fans than any other TV station.

WPIX's sports reputation, however, does not rest solely on the number of sports telecasts it presents. Its production and engineering staffs have gone all-out to make the quality and interest of WPIX sportcasts second to none.

In their telecasts of the Giants' games WPIX-men use a complete three-camera chain of RCA's latest TV field equipment with the only Zoomar lens used in New York for baseball pickups. A parabolic microphone is used for pickups of sounds around homeplate. This is mounted on the front of the camera booth (see Page 30).

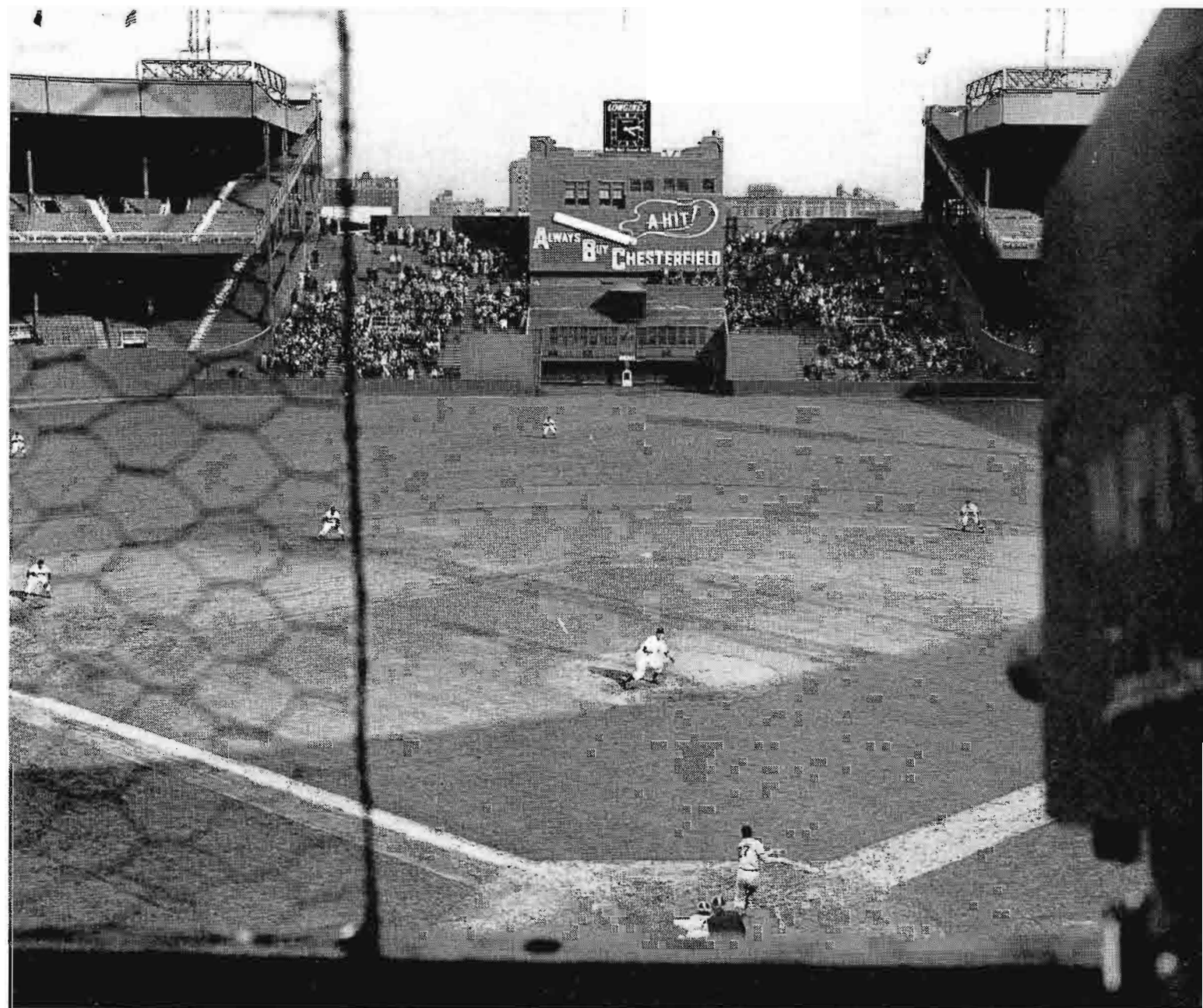
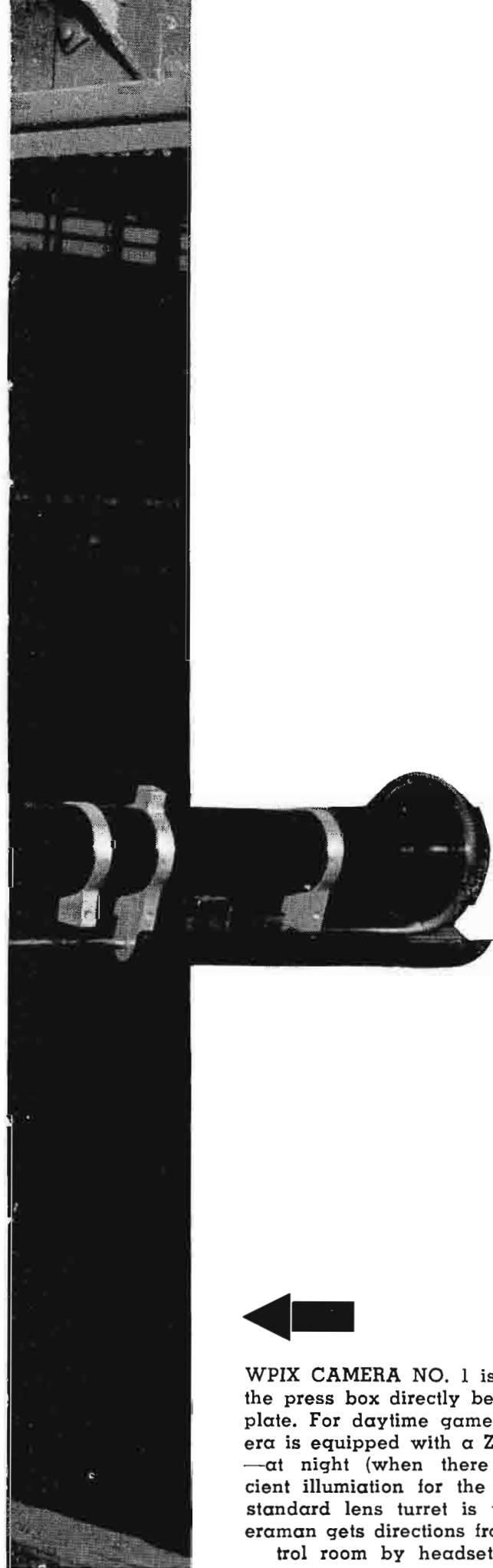

CAMERA NO. 1's VIEW, shown here, is one every fan dreams of. Not the least of the view is the Chesterfield sign in center field. The Giants' games are sponsored on WPIX by Chesterfield and this is the only sign in the park. With this setup commercials are a cinch (see Page 39).



WPIX CAMERA NO. 1 is located in the press box directly behind homeplate. For daytime games this camera is equipped with a Zoomar lens—at night (when there is insufficient illumination for the Zoomar) a standard lens turret is used. Cameraman gets directions from the control room by headset phone.

WPIX's three cameras are located in the press box at the Polo Grounds. Camera No. 1 (above) is directly behind homeplate. The view of the field from this position is also shown above. Camera No. 2 and Camera No. 3 are on the 1st base side about in line with the extension of the 3rd base foul line and directly over the Giants' dugout. These cameras, as well as the view from this position, are shown on the following page.

For daytime games Camera No. 1 is used with a Zoomar lens. The major part of the game is covered by zooming with this camera—thereby eliminating the constant switching and panning required with

turret lenses. The advantage of this is that it has the effect of presenting the game, as closely as possible, as it would look to someone at the ball park—i.e., from a single fixed position.

It is possible to present the complete play with the single Zoomar-equipped camera (see illustration Page 33). However, WPIX finds that variety and interest are added by occasional closeups and color shots. Moreover, when there are several runners on base and close plays may occur at more than one point, it is desirable to have one camera to "follow the ball," another to "follow the leading baserunner," etc. WPIX uses Cameras No. 2 and No. 3 primarily for these secondary shots. However, on occasion the director may use these cameras to cover the general play and his Zoomar for "color."

In the pages that follow, a picture story of the WPIX operation is presented. On Pages 28 to 31 are photographs of the camera positions and equipment setups. On Pages 32 to 39 are pictures made from the monitor screen, which illustrate the possibilities of the system and the general

procedure followed by WPIX. For instance, on Page 32 are monitor-screen photos which show the field of view with the Zoomar lens in various positions. On pages 36 to 38 are photos of typical camera switching sequences used by WPIX.

It should be noted that the shots selected for use were picked because of subject matter, width of field shown, camera angle, etc.—rather than for quality of reproduction. Photographing the kinescope screen, particularly with rapid action, is difficult at best. If the monitor is out of focus or the camera moves the least little bit, the original picture is fuzzy. In addition, when engravings are made for printing the engraver uses a 120-line screen to obtain his halftones. This screen, mixing with that on the original, causes great loss of detail—especially in small-size reproduction. In many cases it was necessary to use some photos of inferior quality in order to illustrate a particular switching sequence. Thus the reader, in looking at these pictures, should bear in mind that they illustrate only what shots WPIX uses—not how good they are.

WPIX'S CAMERA SETUP GIVES THE DIRECTOR A WIDE CHOICE OF SHOTS

WPIX CAMERA NO. 1 (see preceding page) is located in the press box directly behind homeplate—a position from which it commands a fine view of the whole field, or any part of the field, with minimum policy.

WPIX CAMERAS NO. 2 AND NO. 3 (right) are also located in the press box, but some distance to the right (toward 1st base) of the No. 1 camera position. They are approximately in line with the extension of the left field foul line, and directly over the Giants' dugout, which makes possible swell shots of Giants' players going on and off the field. In this view engineers are adjusting parabolic microphone which picks up sounds at homeplate.

CAMERAS NO. 2 AND NO. 3 VIEW (below) as seen through the optical viewfinder on the RCA TK-30A cameras looks like this. Rings seen when looking through viewfinder help operator keep play in view on fast pans. Scoreboard is situated so that it can be easily picked up from this camera location. Large size replicas of Chesterfield package at either end of scoreboard are painless commercials.

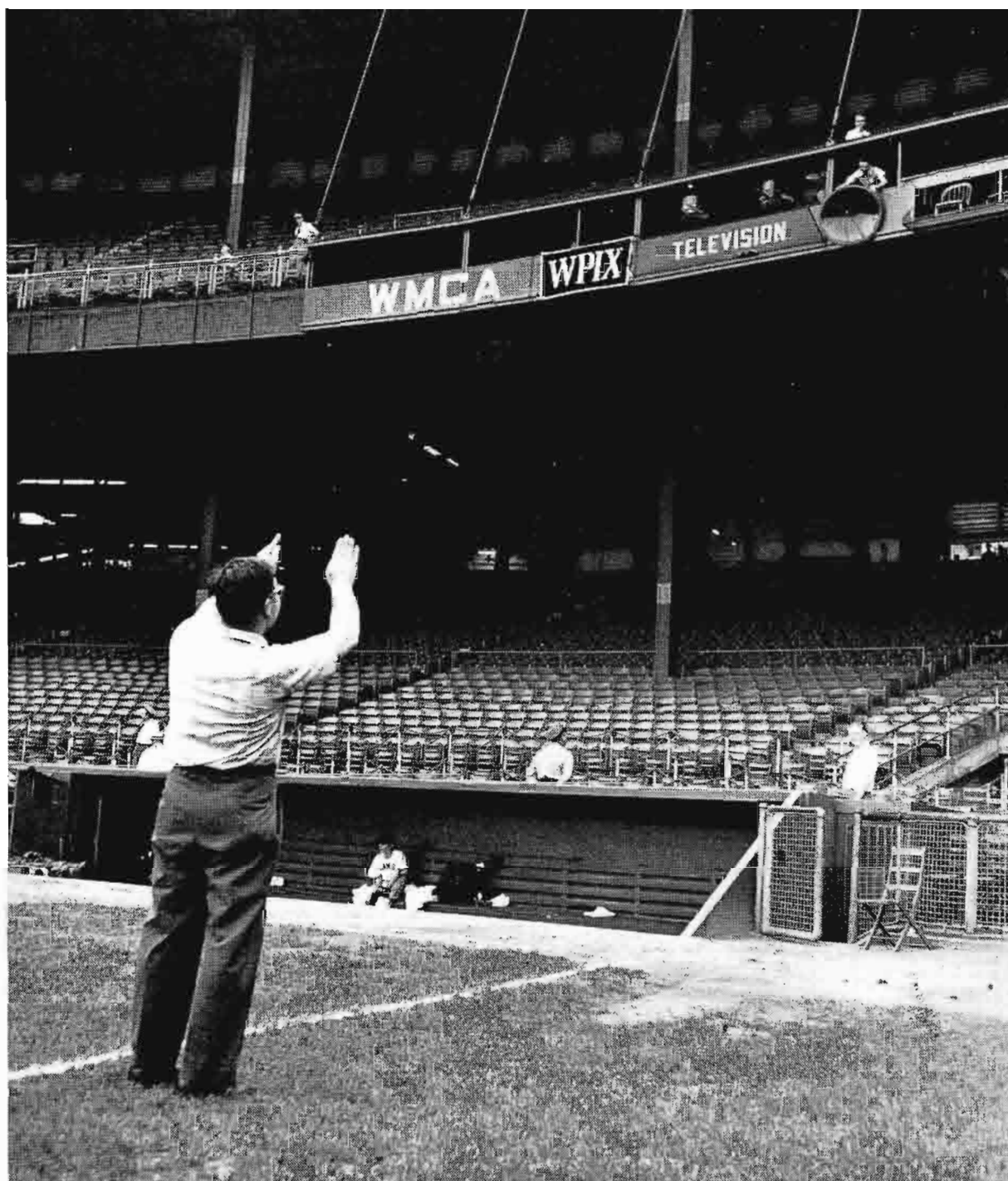

HE SELECTS ONE OF THREE CAMERA PICTURES FOR TRANSMISSION

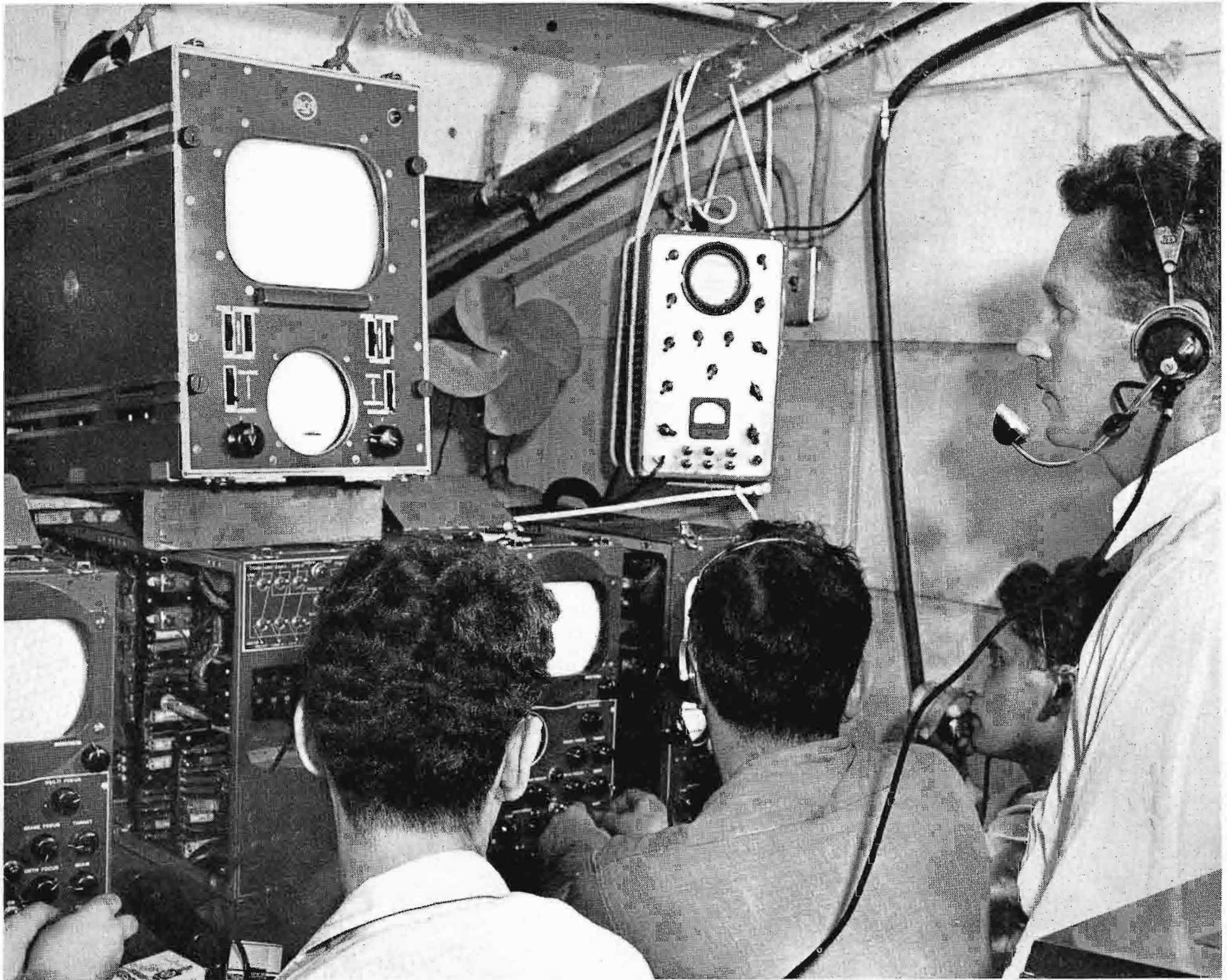

WPIX CONTROL FACILITIES are located in a room far below the stands of the Polo Grounds. In this room, a corner of which is shown above, is all of the audio and video monitoring and switching equipment used by WPIX in its baseball telecasts. A cable leads from each camera to a camera control unit located in this room (bottom row of equipment units in picture above). Each of these camera control units contains controls for adjusting the quality and brightness of the picture picked up by the camera with which it is associated. In addition each contains a kinescope on which appears the picture picked up by that camera. Video operators sitting in front of these camera control units keep each camera adjusted for the best possible picture. Meantime Director Jack Murphy (standing at right), WPIX's Senior Remotes Director, tells cameramen (by means of headset phone) where to aim cameras.



DIRECTOR MURPHY SEES three pictures like these (one from each camera) on the three camera control units. Selecting the one he wants to send over the air he gives his instructions to the operator in front of him, who pushes a button to place the proper camera on the air. The picture actually going out is shown at all times on the large monitor (top level of picture above). When action is slow, the director has it fairly easy—but on fast plays involving several base runners he must make split-second decisions, and they've got to be right every time.

WIDE RANGE OF WPIX'S ZOOMAR-EQUIPPED CAMERA MAKES THE DIRECTOR'S JOB EASIER

Director Jack Murphy's job of "calling the shots" is simplified by the fact that his No. 1 Camera with its Zoomar lens can quickly "zoom" from a wide angle view, showing a large part of the field, to a closeup (narrow angle) view, showing the batter at homeplate nearly full screen height. As the illustrations on this page demonstrate, he can have a picture equal to that of any of the four standard-size lenses (90mm, 135mm, 8½", 13") or any size in between. Thus he does not have to switch from one camera to another in order to change from his cover shot to a closeup.



1 With WPIX's Zoomar full "in" the field of view is approximately equal in size to that obtained with a 13" lens in a standard turret-type camera.



2 Opening the Zoomar a bit provides this view. Width of field at the batter's box is about 12 feet—approximately the same as that of a standard 8½" lens.



3 Opening the Zoomar still farther provides this view, which is about midway between that of 8½" and 135mm lenses. Zoomar has advantage of continuous range.

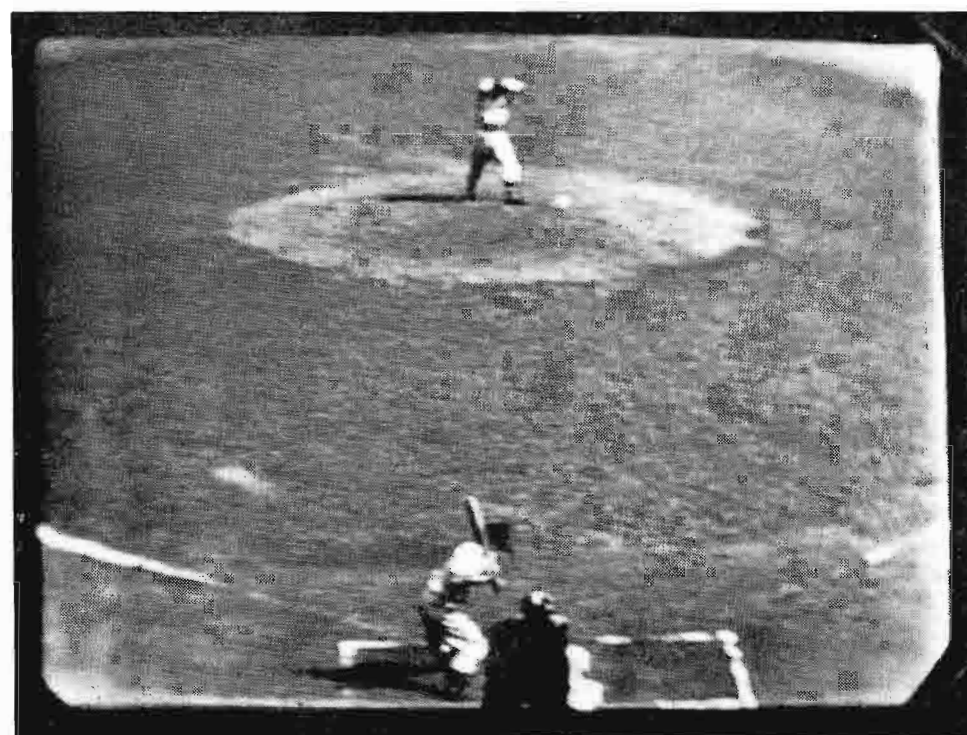

4 This is WPIX's "cover" shot, obtained with Zoomar nearly full out. It shows umpire, catcher, batter and pitcher full length—field of view equals that of 135mm lens.



5 With a man on 2nd base this shot, obtained with Zoomar full out, is used. It corresponds roughly to the field of view obtained with a 90mm lens.

IF HE WISHES HE CAN DO A WHOLE SWITCHING SEQUENCE WITH THE ZOOMAR CAMERA ALONE

The flexibility of the Zoomar—and its ability to take the place of all the regularly-used standard lenses is such that Director Murphy, if he so elects, can run a whole sequence with the Zoomar camera only—as shown by the series of pictures at the right and below. By so doing he makes unnecessary the split-second switches which not infrequently show the outfielder *after* he has caught the ball. If, for variety, he elects to use the Zoomar for “color” shots he can get dramatic effects like those depicted on Pages 35 and 36. The action of the Zoomar in first showing a wide field of view, then gradually *and smoothly* bringing up one part of that field for closer scrutiny, is like the action of the eye itself. It thus makes the depiction of the game more “natural” and thereby less confusing to the viewer.



1 Sequence opens with batter taking his place at the plate. This is a medium-close shot with a Zoomar lens (camera in upper press box directly behind homeplate).



2 As pitcher gets set, cameraman zooms out to wide angle position. This is the “standard” or “cover” shot used during the whole time the batter is at plate.

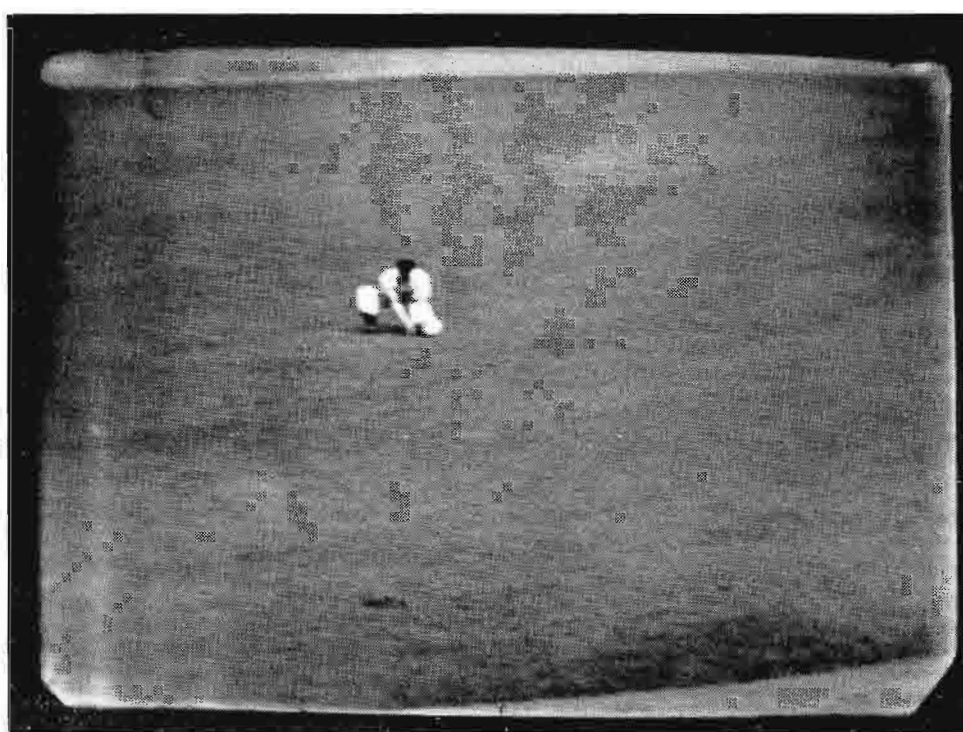

3 If the batter hits the ball the Zoomar cameraman “follows the ball,” narrowing his field as he goes. On an infield play with the Zoomar full closed he gets a semi-closeup of the infielder.



4 If the ball is a grounder and there is a play to first, the Zoomar cameraman continues to “follow the ball” and gets a shot like this at first base.



5 If the hit is to the outfield the Zoomar cameraman follows the ball out gradually zooming in on the outfielder running after the ball.

WHAT THE VIEWER SEES AS THE CAMERAMAN

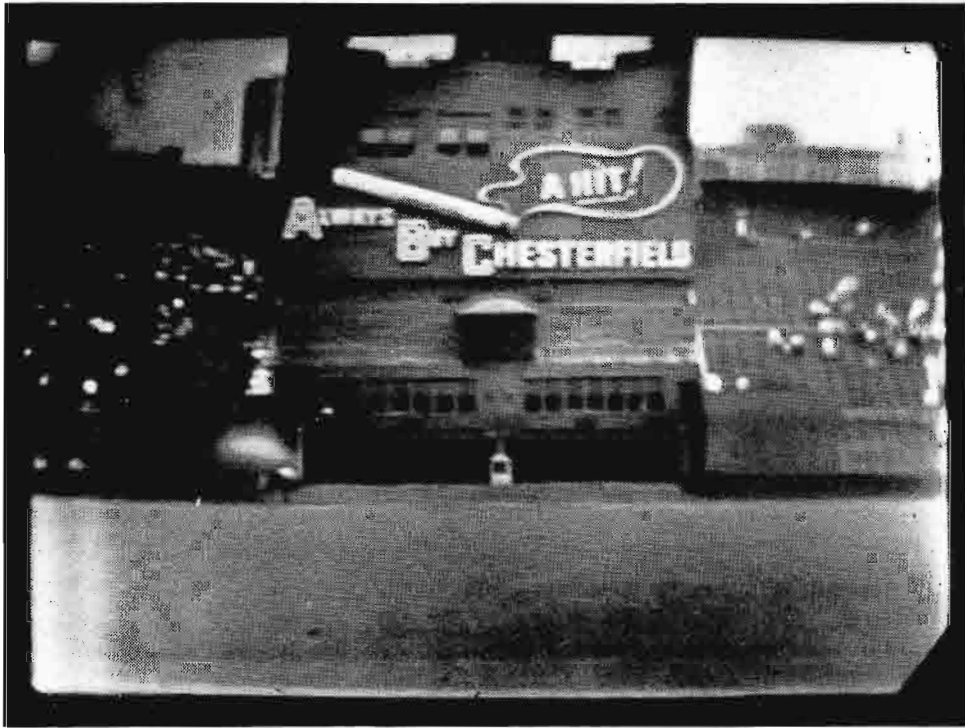

Chesterfield Sign (Zoomar, full out).

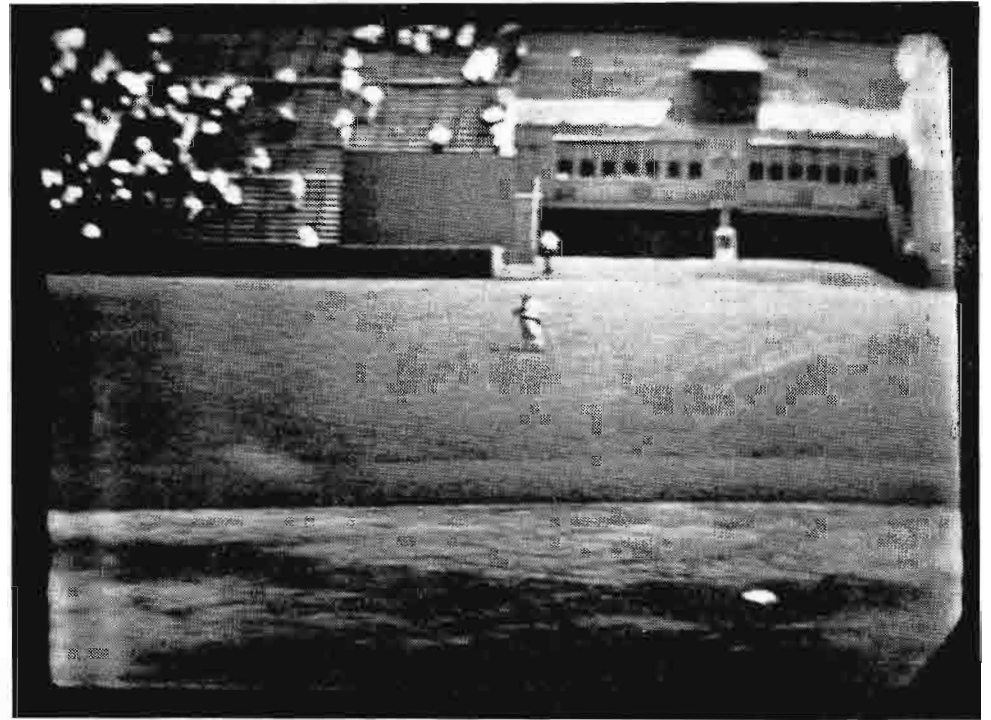

Centerfielder (Zoomar, full out).

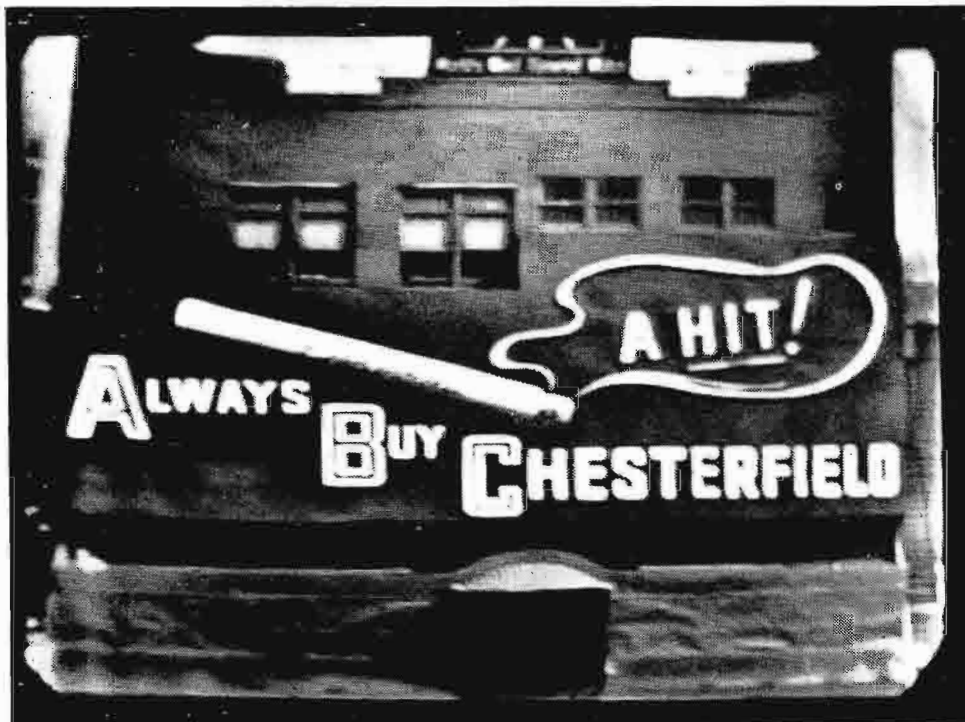

Chesterfield Sign (Zoomar, midway).

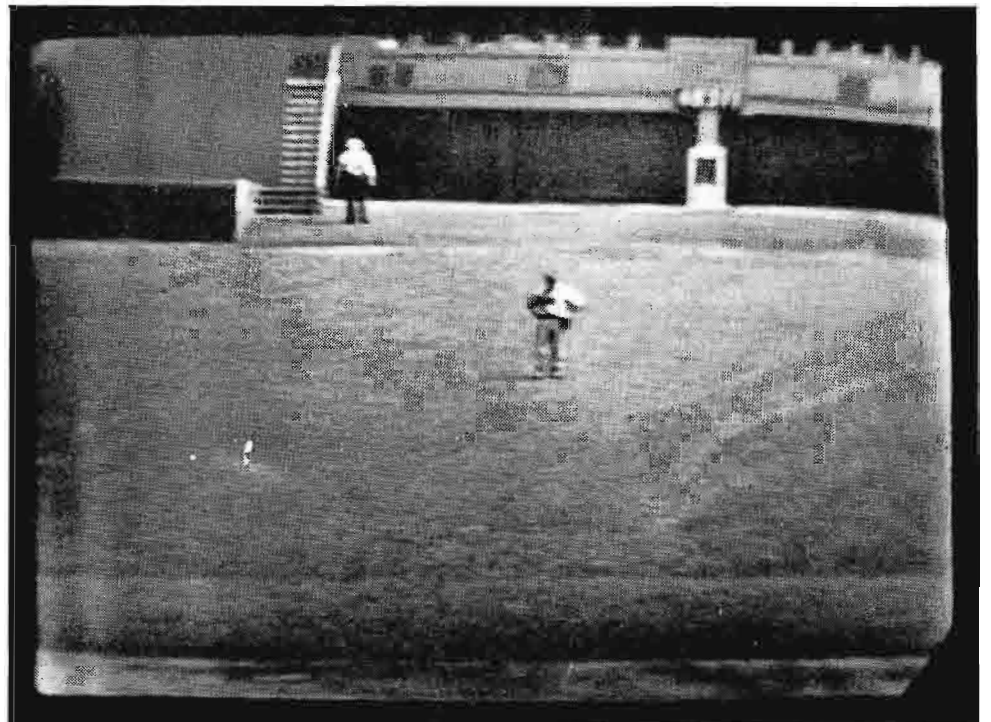

Centerfielder (Zoomar, midway).



Chesterfield Sign (Zoomar, full in).

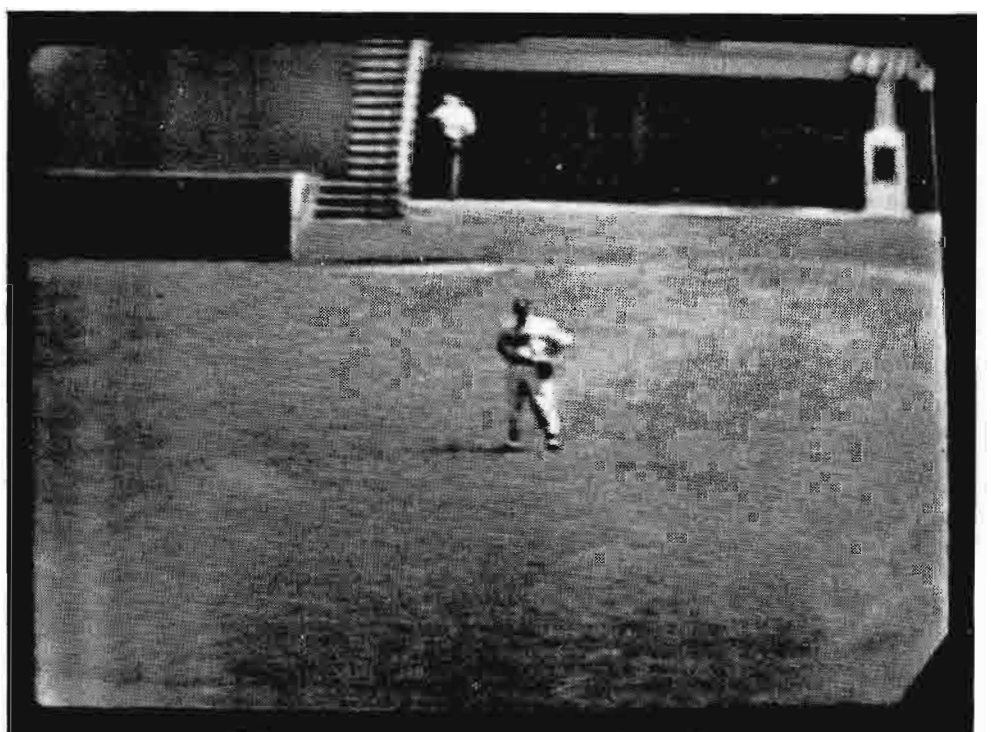

Centerfielder (Zoomar, full in).

"ZOOMS IN" ON VARIOUS PARTS OF THE FIELD

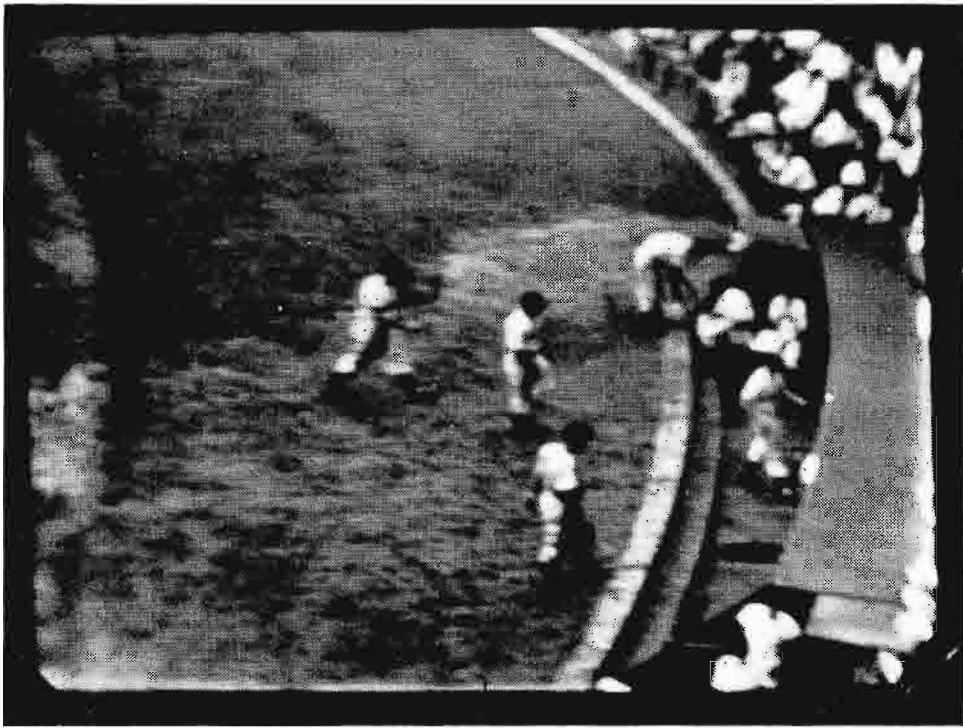

Visitors' Dugout (Zoomar, full out).

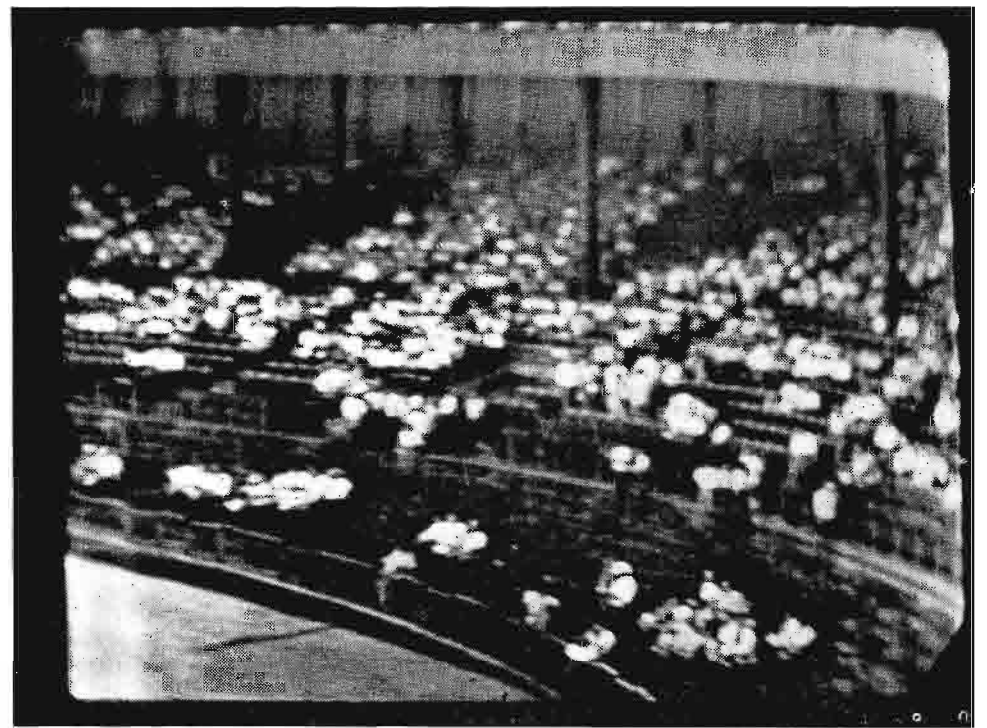

Leftfield Stand (Zoomar, full out).

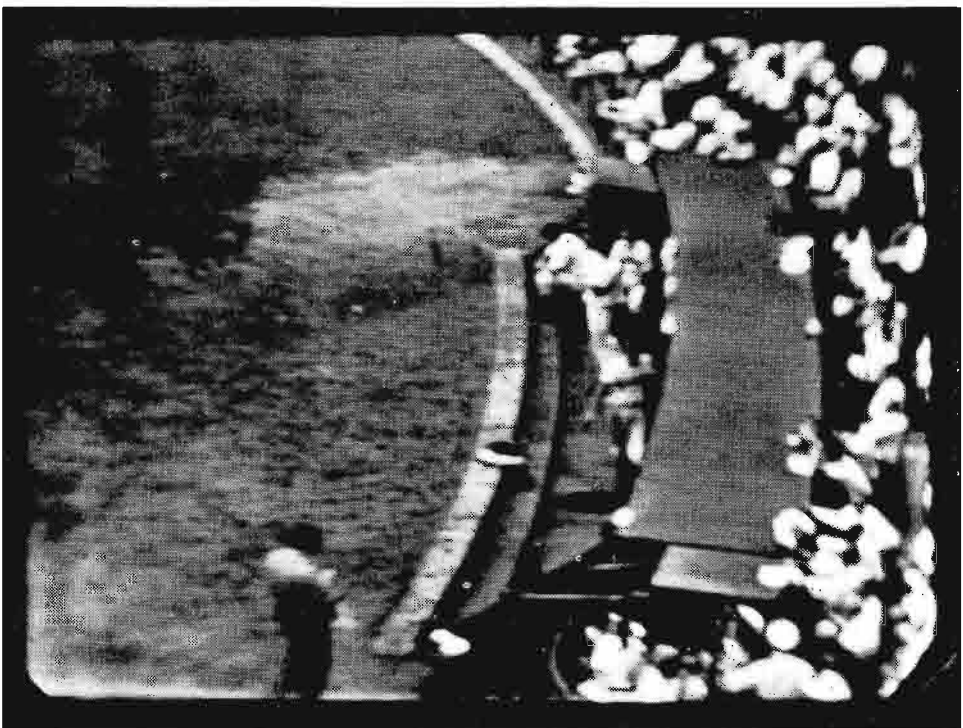

Visitors' Dugout (Zoomar, midway).

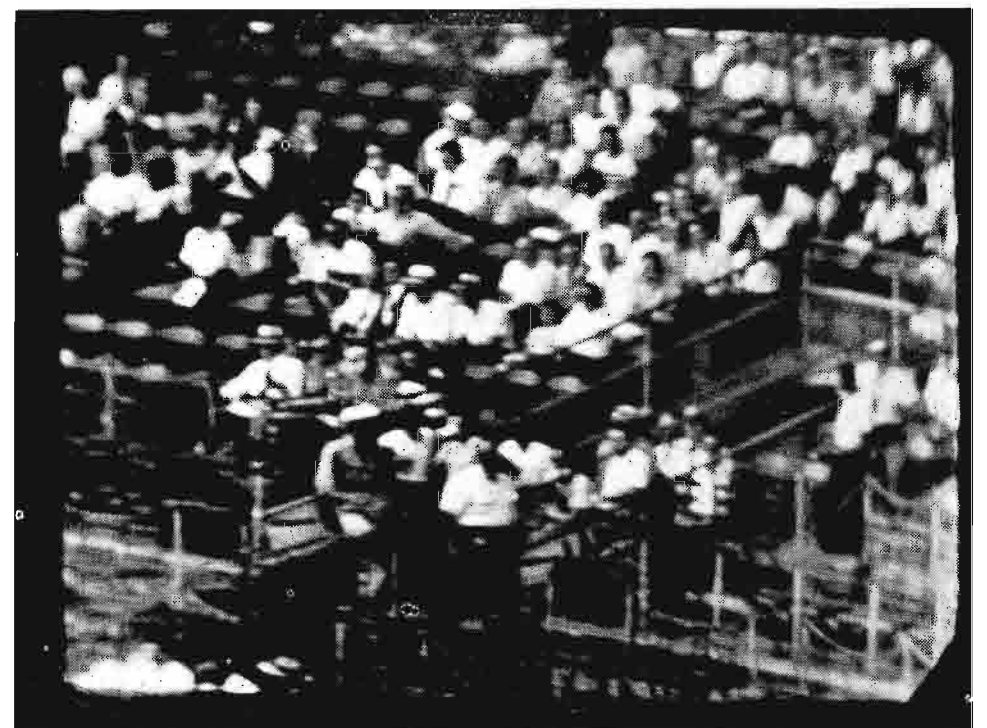

Leftfield Stand (Zoomar, midway).

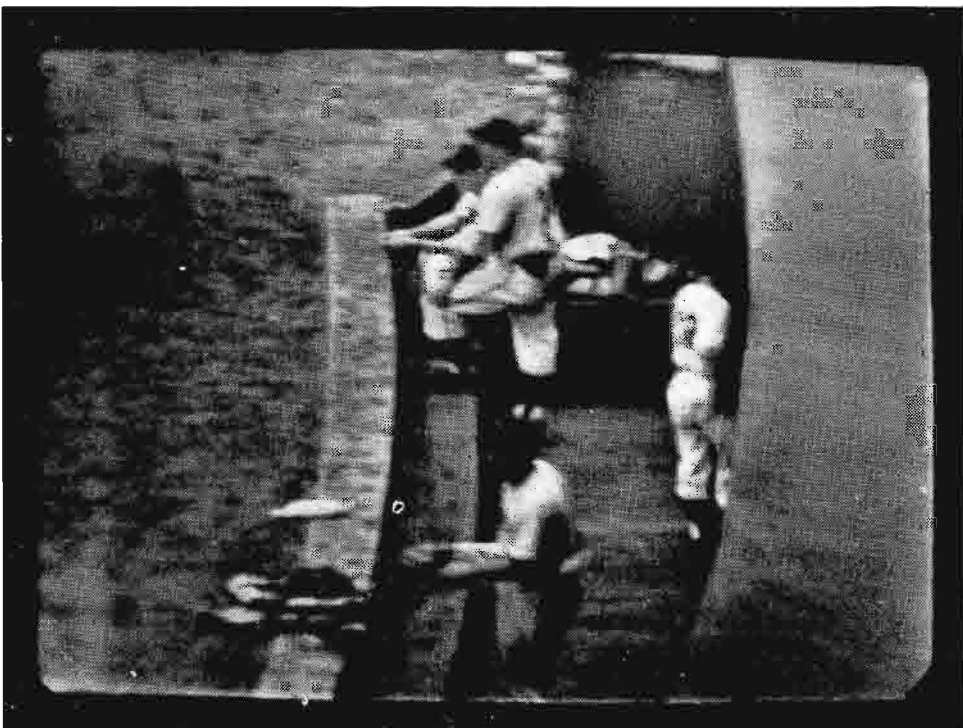

Visitors' Dugout (Zoomar, full in).



Leftfield Stand (Zoomar, full in).

IN TYPICAL SWITCHING SEQUENCE WPIX MIXES ZOOMAR SHOTS WITH CLOSEUPS FROM CAMERAS No. 2 & 3

Although the Zoomar alone can depict a whole play, the dramatic effect is heightened and change of pace achieved by intermixing Zoomar and closeup shots. In a typical infield play with no men on base Murphy usually calls a series like that shown at right and below. Sequence opens with closeup of batter (17" on Camera No. 3) and pitcher (13" on Camera No. 2), switches to Zoomar for pitch and subsequent action. If the play to first is a short one (as from the 2nd baseman) the director may elect to stay with his Zoomar (which continues to follow-the-ball). However, more often he switches to No. 2 Camera (who is following the runner with his 13") and then gets a good closeup of the play.



1 Typical sequence opens with a closeup of the batter walking up and taking his position at the plate. This is made by No. 2 Camera with a 17" lens.

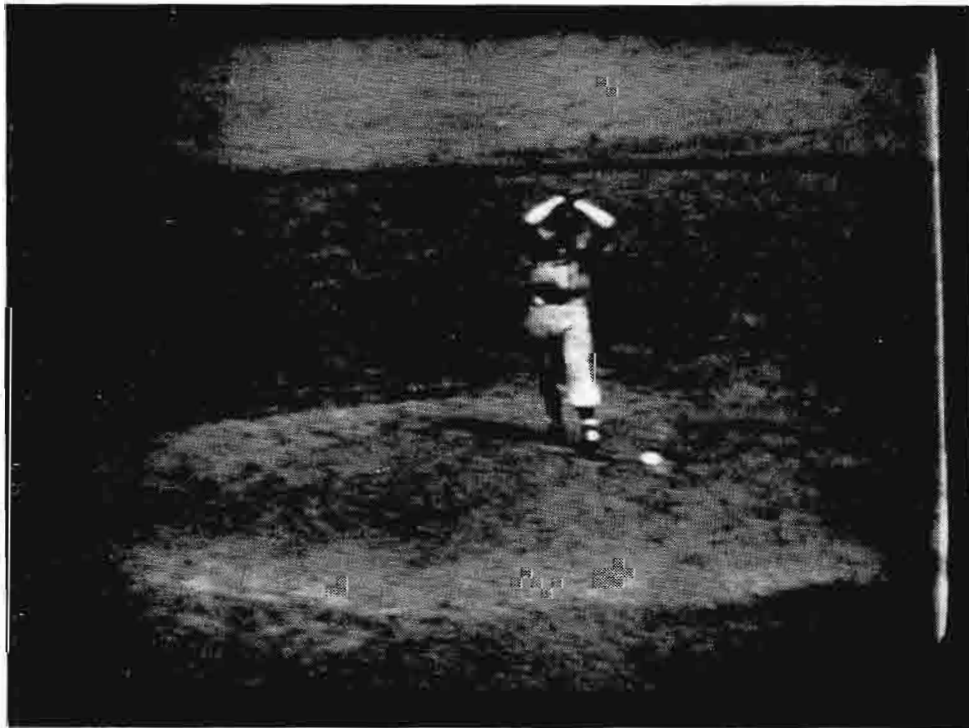

2 Second shot is usually a medium closeup of the pitcher getting set to throw. This is made by No. 3 Camera using either an 8½" or 13" lens.

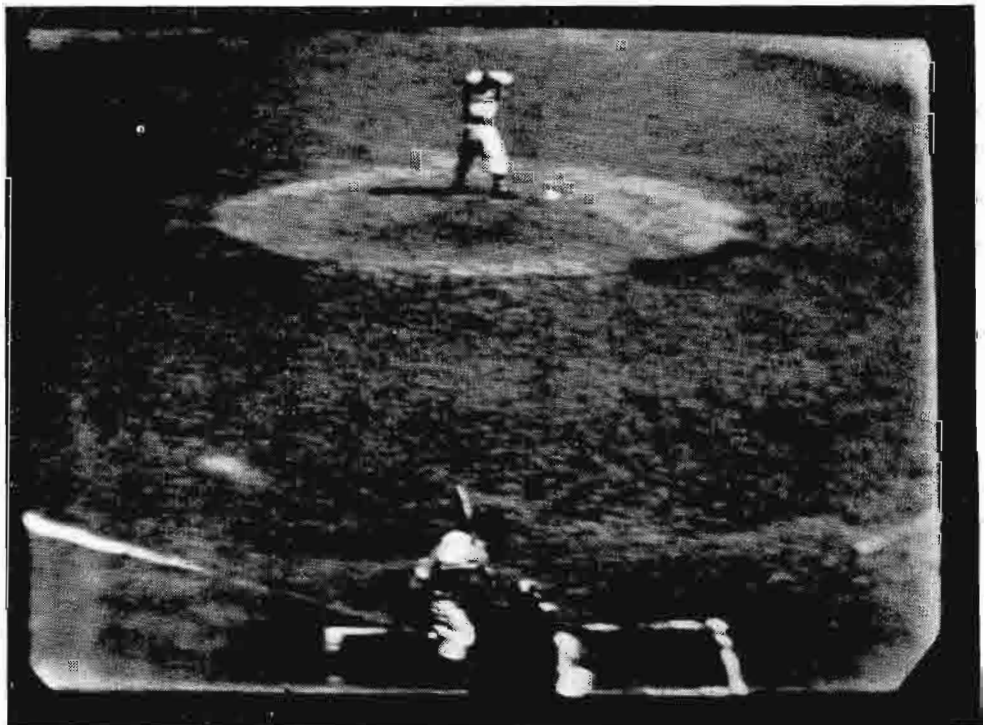

3 As the pitcher is about to throw a switch is made to Zoomar on Camera No. 1, for the WPIX "cover" shot shown above.

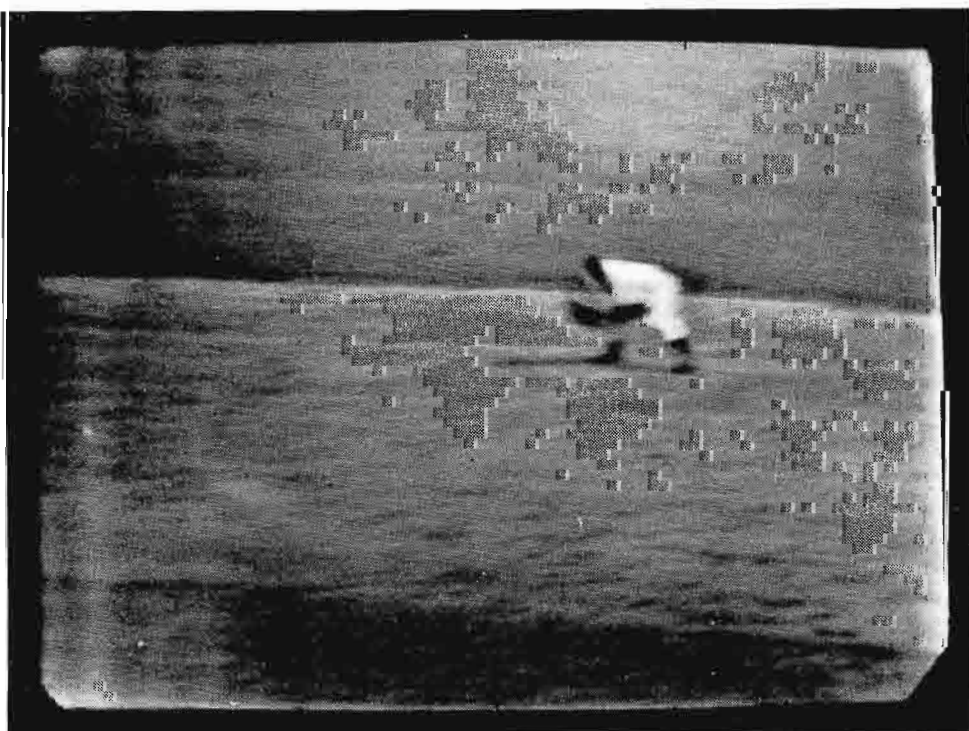

4 If the batter hits the ball, No. 1 cameraman "follows the ball"—zooming in as he goes for a close shot of the infielder scooping up the ball and throwing to first.



5 Usually a switch is made (while the ball is in the air) to the No. 2 Camera (which is following the runner) and thus gets a good closeup of the play at first.

WITH A MAN ON BASE, No. 2 CAMERA "FOLLOWS THE RUNNER" AND IS READY FOR CLOSE PLAY AT SECOND

When there is a runner on base the balance of attention shifts somewhat and the sequence of camera switching takes this into account. A typical WPIX sequence, as shown on this page, opens with a Zoomar shot of runner on base, switches to pitcher to show him "worrying" about the runner, and then to Zoomar for cover. Zoomar has an advantage here because if pitcher throws to first a slight pan to right and a zoom in gives a good closeup without the confusion of a camera switch. In case of a hit Zoomar follows ball, No. 2 follows advanced runner. Thus the director is set for closeup at either 1st or 2nd base.

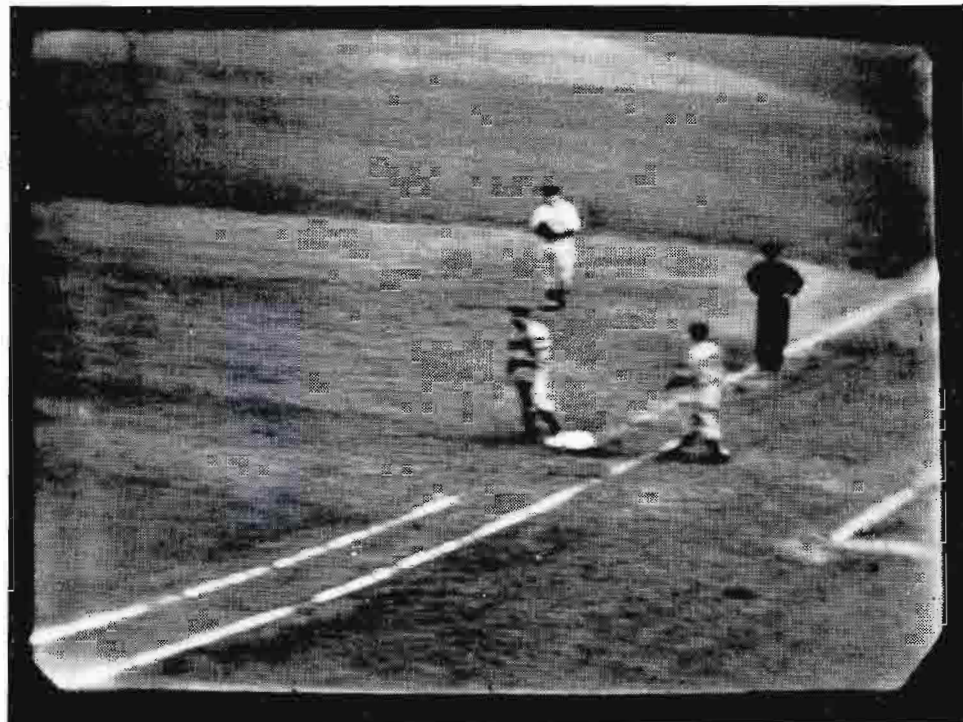

1 With a man on base WPIX usually opens with a shot of the base-runner. This may be a medium closeup with the Zoomar on Camera No. 1 (as above) or a closer view with the 13" on Camera No. 2.



2 Second shot in this sequence is usually a closeup of the pitcher as he looks the situation over. Usually this is with the 17" lens on Camera No. 3.



3 As the pitcher gets set to throw, switch is made to the No. 1 Camera with the Zoomar. If the pitcher makes a throw to first (above) a slight pan will get the whole action.



4 If there is a play at second (as in a double play or force out) switch is made to No. 2 Camera which follows the baserunner at all times. Thus, a closeup of the play at second is always ready.



5 No. 3 Camera follows with a closeup, thus the last picture of the sequence may be a closeup of the runner getting up and dusting himself off.

ON AN OUTFIELD HIT WPIX USUALLY FOLLOWS THE BALL OUT AND BACK WITH THE ZOOMAR

Although the Zoomar has a wide range its maximum closeup position is about that of a 13" standard lens. On shots to the very deep outfield it cannot equal the closeups obtainable with the 17" (or larger lenses). Thus, on outfield hits, such as illustrated by the sequence shown on this page, WPIX sometimes shifts to the 17" on Camera No. 3. However, if the ball is bouncing around the outfield (so that on a closeup the viewer might be confused as to what spot he was looking at) the director usually stays with the Zoomar all the way out and back.



1 This sequence, of course, may start the same as either of the others. The director, however, normally varies the opening shot by using a slightly different view of the batter.

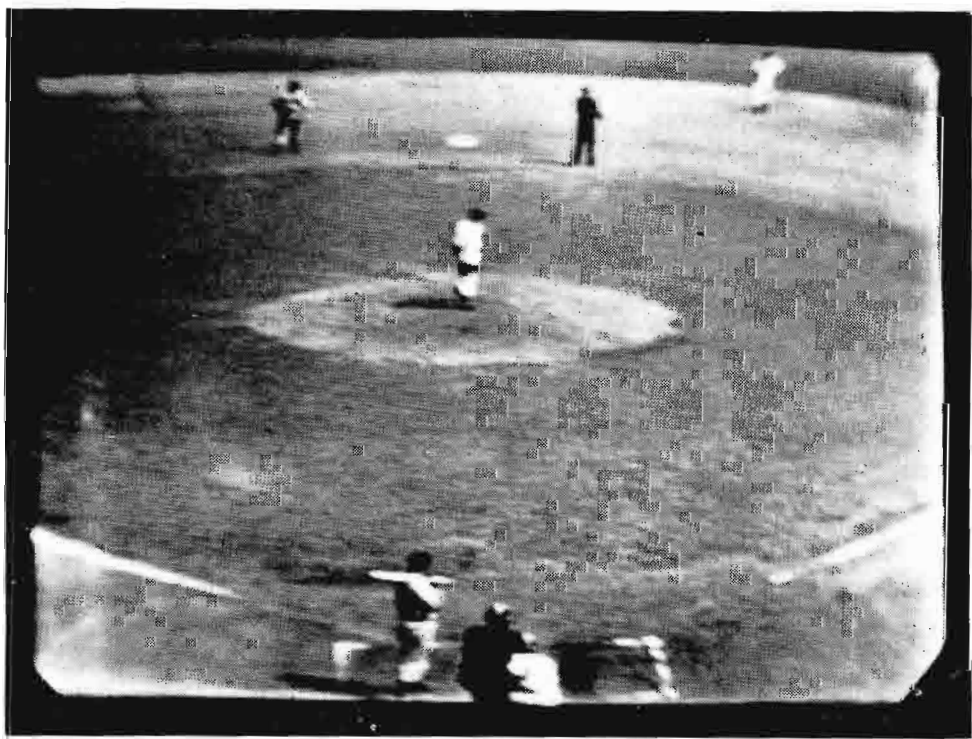

2 In either case, switch is always made to the No. 1 Camera (with the Zoomar) just before the ball is hit. The ability of this camera to follow-the-ball is the paramount consideration.

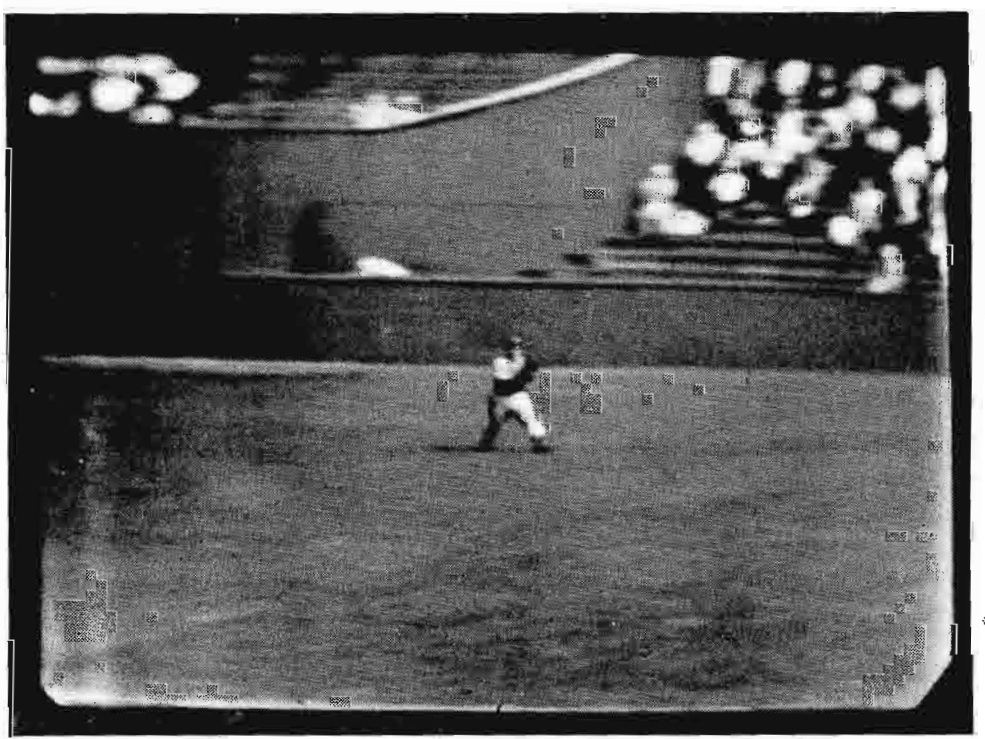

3 If the batter hits a fly ball the cameraman, acting on preset instructions, follows the ball, gradually changing his picture to center on the outfielder.



4 In case the ball gets past the outfielder, switch to No. 2 Camera with a 17" lens is a possibility, but staying with the Zoomar is less confusing to the viewer.

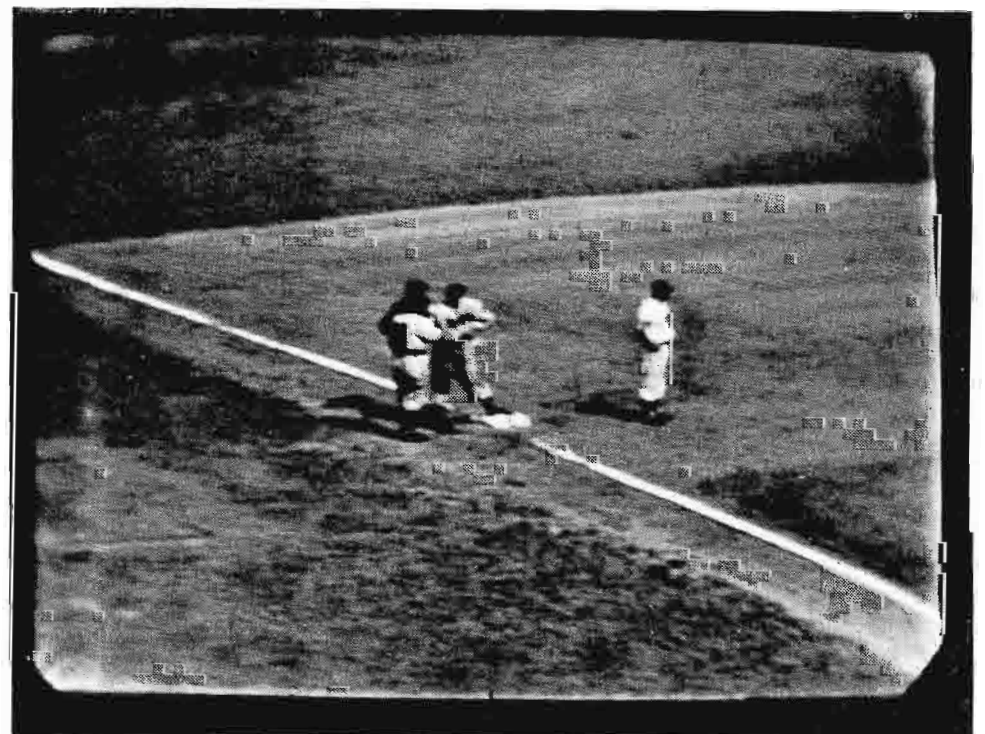

5 Unless there are base runners other than the hitter, WPIX follows the ball back to the infield with the Zoomar for the picture above (medium shot with the Zoomar).

COMMERCIALS COME NATURALLY ON WPIX BASEBALL TELECASTS

Chesterfield Cigarettes are omni-present in WPIX baseball telecasts. It's not an accident—it was planned that way. The "Always Buy Chesterfield" sign (below, right) in centerfield is the only sign in the park. As if its all-dominating position wasn't enough, it is given greater interest by the fact that the word "HIT" lights up on a base hit, the center E in Chesterfield on an error. The TV cameras open and close with dramatic zooms on this sign. In between they show closeups of the large-size Chesterfield packages (below) mounted at either end of the scoreboard—pickup commercials read by Russ Hodges, WPIX sports announcer (right)—who by sheerest coincidence always seems to be just opening a new package of his sponsor's product.

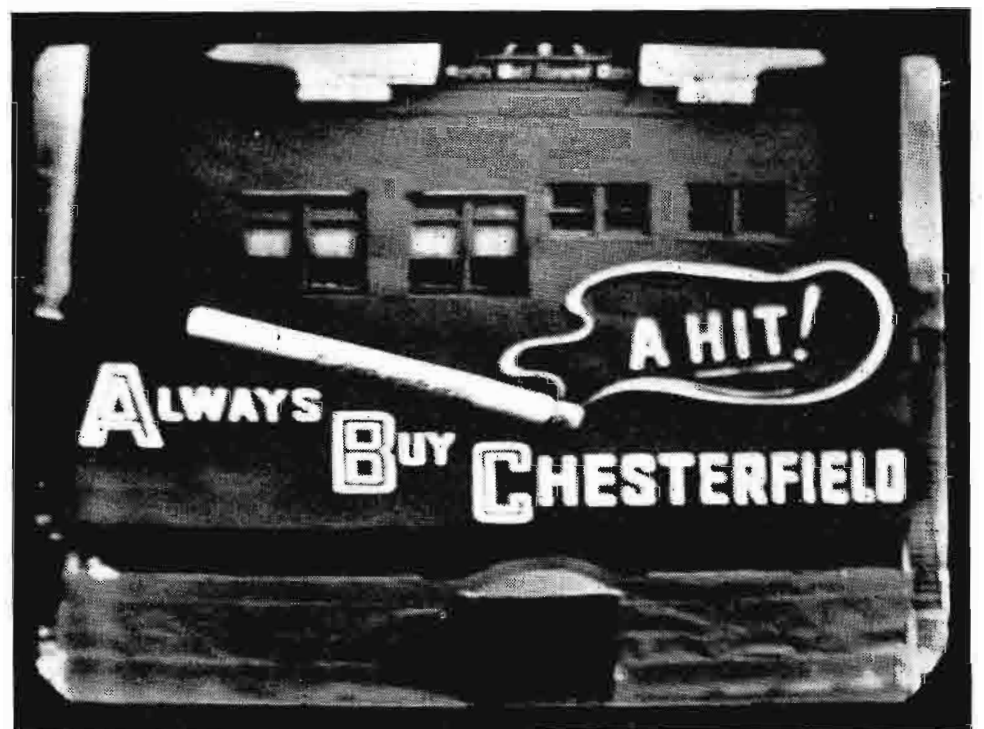
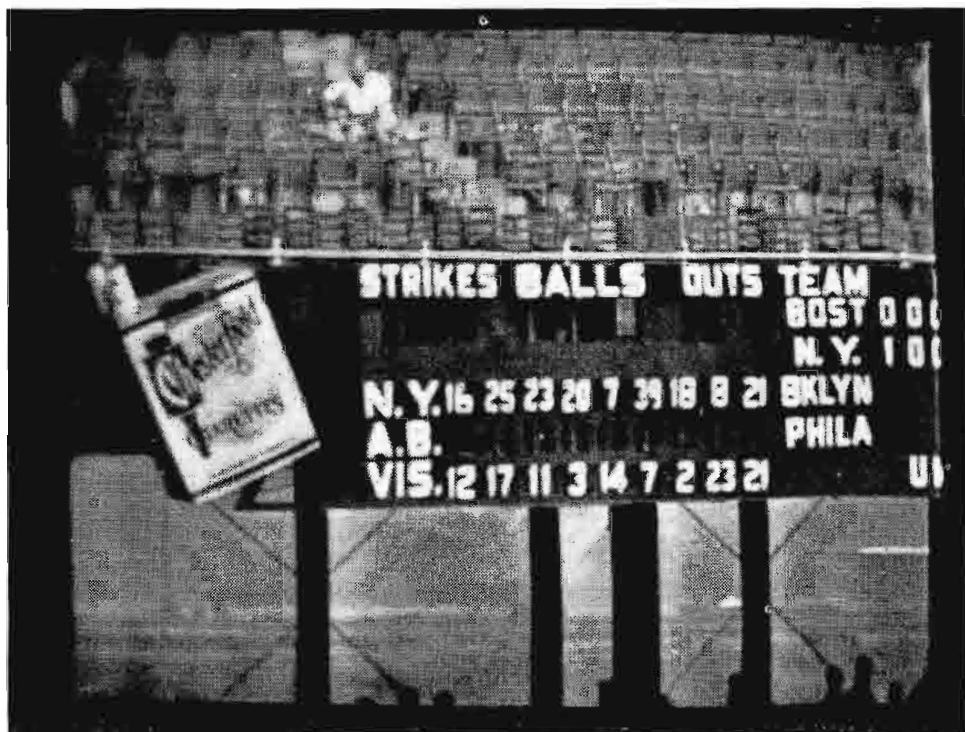

AND THEY DO IT ALL WITH RCA EQUIPMENT

As long as we've finally gotten around to the subject of commercials, it seems only fair to state that all the equipment WPIX uses at the Polo Grounds is RCA, including the cameras, the control units and the microwave gear. And nearly everything at WPIX proper, including the studio cameras, camera control units, transmitter and antenna are also RCA.



(Right). WPIX engineers examine one of the RCA TK-30A cameras used for baseball television by the station. Grouped around the RCA camera are (from left to right) William Sloat, assistant for engineering, peering over Chief Engineer Tom Howard's shoulder as he points out one of the features of the camera to Robert L. Coe, station manager; Otis S. Freeman, assistant for operations; and Clifford E. Denton, manager of research and development.



The "new look" at **KTBS**

SHREVEPORT STATION BOASTS NEW STUDIOS, NEW TRANSMITTER, NEW FREQUENCY AND NEW HIGHER POWER

After almost a year's construction activity, involving the building of new studios and a complete new transmitting plant, Station KTBS, Shreveport, Louisiana NBC outlet, has recently begun operation on 710 kilocycles with 10,000 watts power, daytime, and 5,000 watts at night. The station's former power was 1,000 watts on a frequency of 1480.

In order to obtain a true picture of KTBS's new far-reaching signal, it is only

necessary to make a comparison with measurements of signal intensity formerly put forth by the station. Under its former operation, KTBS's half-millivolt contour included an area of 2,120 square miles, whereas the same contour under its new power of 10,000 watts on 710 kilocycles embraces an area of 23,200 square miles or more than ten times the former area. Based on population, the station is now able to reach five and one-half times the

number of listeners served before. This new coverage includes 31 counties and parishes in Arkansas, Louisiana and Texas, as compared with only four Louisiana parishes it formerly served.

The entire expansion and reorganization program which KTBS has undergone during the past two years has been made under the supervision of C. K. Beaver who took over the station's management in August, 1946.

FIG. 1 (opposite page). This modernistic two-story building, with almost 7000 square feet of floor space (plans on page 43), houses the new studios and the offices of KTBS. Distinctive note is given to the building by the large free-standing letters and microphone, and the glass-face clock which is lighted from the inside.

FIG. 2 (right). Polycylindrical diffusers made of birch plywood are used for acoustical control in all of the KTBS studios. An interesting touch is the fact that the absorption elements (which are intermixed with the smooth-surface acoustical panels) have the same curvature as the polycylindrical diffusers—as do also the curved glass control room windows. By this means the walls are given more symmetry than is usual in this type of construction. Studios were designed by Mr. Lester C. Haas, Shreveport architect who is shown here explaining the construction to Mrs. Gifford of the KTBS staff.



KTBS's New Studios

Work on the studio building, which also houses the station's management and personnel, was completed early last fall and broadcast operations, under the old frequency and power, continued from there prior to the completion of the station's new transmitting facilities. The building, designed by Lester C. Haas, Shreveport architect, represents one of the most modern, scientifically-designed radio centers in the south. Interior acoustical design of the studios was handled by Dr. C. P. Boner of the University of Texas, one of the nation's outstanding authorities on studio acoustics. Dr. Boner was one of the pioneers in the use of polycylindrical diffusers, a treatment carried out in all KTBS studios.

The building which houses the new studios of KTBS is two stories in height and was constructed at a cost of \$300,000. One entire side of the building is made up of offices, occupied by the station's management, personnel and its various departments, while the opposite side is devoted to studios and control rooms. The two main studios are two stories in height. The largest of these, Studio A, provides approximately 2000 square feet of floor space, and will accommodate an audience of 75 persons or more. Studio B has approximately 500 square feet of floor space and serves as origination point for shows which do not require or permit studio audiences. A smaller "announcer's studio" is located between Studios A and B. Also located between the studios are the twin



CECIL K. BEAVER, KTBS' General Manager—one of the pioneers of broadcasting in the southwest—planned and supervised the construction of the new KTBS.



FIG. 3 (left). This is a view of the lobby and reception desk in the modernistic new KTBS studios. Glass entrance doors are just out of view to the right. The three windows at the back look into Studio A (see floor plan, opposite page).

control rooms which sit atop each other. This arrangement permits independent operation of both of the larger studios simultaneously.

Studio A is intended for audience participation shows, is designed acoustically for organ, orchestra, chorus and other large musical presentations. Studio B is designed acoustically for forum discussions, small vocal and instrument presentations. The announcer's studio is especially designed for high quality voice reception. The audition room (on 2nd floor overlooking Studio B) is designed for good quality reception and is isolated to provide facilities for broadcasting by dignitaries and special guests, not requiring highest fidelity sound treatment.

The AM control room is on the main floor, with full vision of all three of the studios, and within easy access to the music library. The FM control room, directly above, has full view of the main studios and partial view of the audition room and the clients' viewing room. Both control rooms are designed to permit announcing, if required.

The studio and control portion of the building can be separated from the ad-

ministration portion of the building by closing the sliding door at the reception area and the hinged door at the foot of the stairs, thereby leaving these areas accessible to the public after normal working hours.

Polycylindrical diffusers are used for the acoustic treatment of the walls and ceilings of the main studios, and similarly designed diffusing panels for the walls and ceilings of the announcers' studio. The cylinders were made at the site. Although designed for 8 foot lengths of plywood, it was found that the only available lengths

of $\frac{1}{8}$ inch birch three-ply plywood were 5 feet, which accounts for the abundance of joints in the cylinders; this is more noticeable in the photographs than to the eye. Absorption elements were made by perforating plywood on the job; on the ceiling and in the announcers' studio the absorption elements were covered with monks cloth. This is the first instance where curved glass has been used for the interior glazing of the triple-glazed viewing windows. The curves coincide with the curvatures of the plywood panels and by using these curved windows larger glass areas than are usually tolerated were incorporated in the design. The floor pattern of standard asphalt tile in two group C colors (grey and green) was designed to tie together the several parts of the building to create a continuous flow of interest through the necessarily isolated passages. The NBC background is red sheet rubber to cushion foot-fall at the live area.

Distinguishing characteristics on the exterior of the building are the glass clock, illuminated from the interior, the free standing letters and the "microphone" which is equipped with a speaker for broadcasting the NBC chimes on the hour, half hour, or quarter hour, and which may also be used for special messages or programs.



FIG. 4 (right). Marvin L. Perry, Chief Studio Control Operator, at the console in the AM control booth. Equipment—all RCA—includes a 76-C Consolette, a BCS-1A Master Switching Console, 70-D Turntable and LC-1A Speakers. The FM control room, directly above, is similarly equipped.

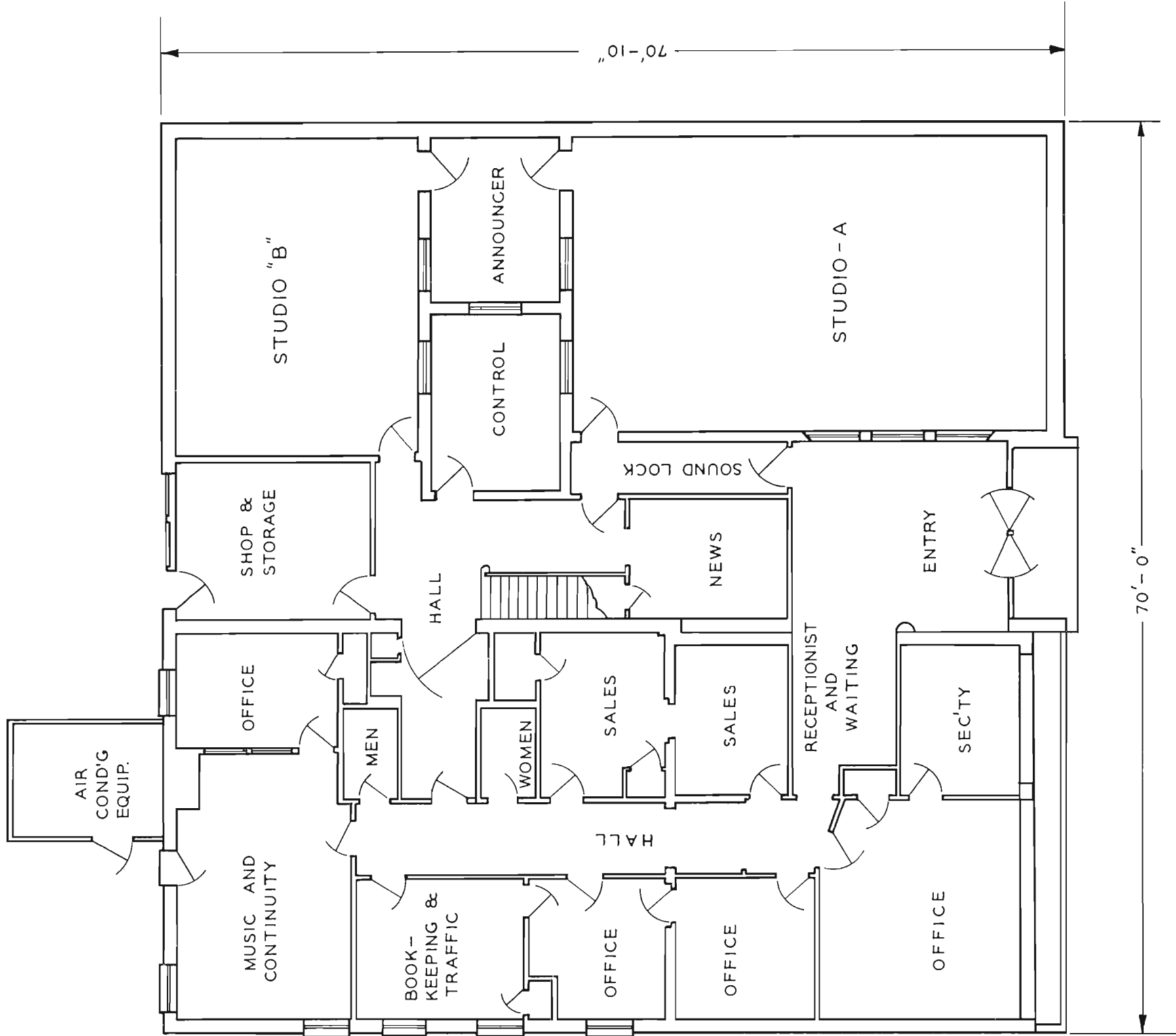

FIRST FLOOR PLAN

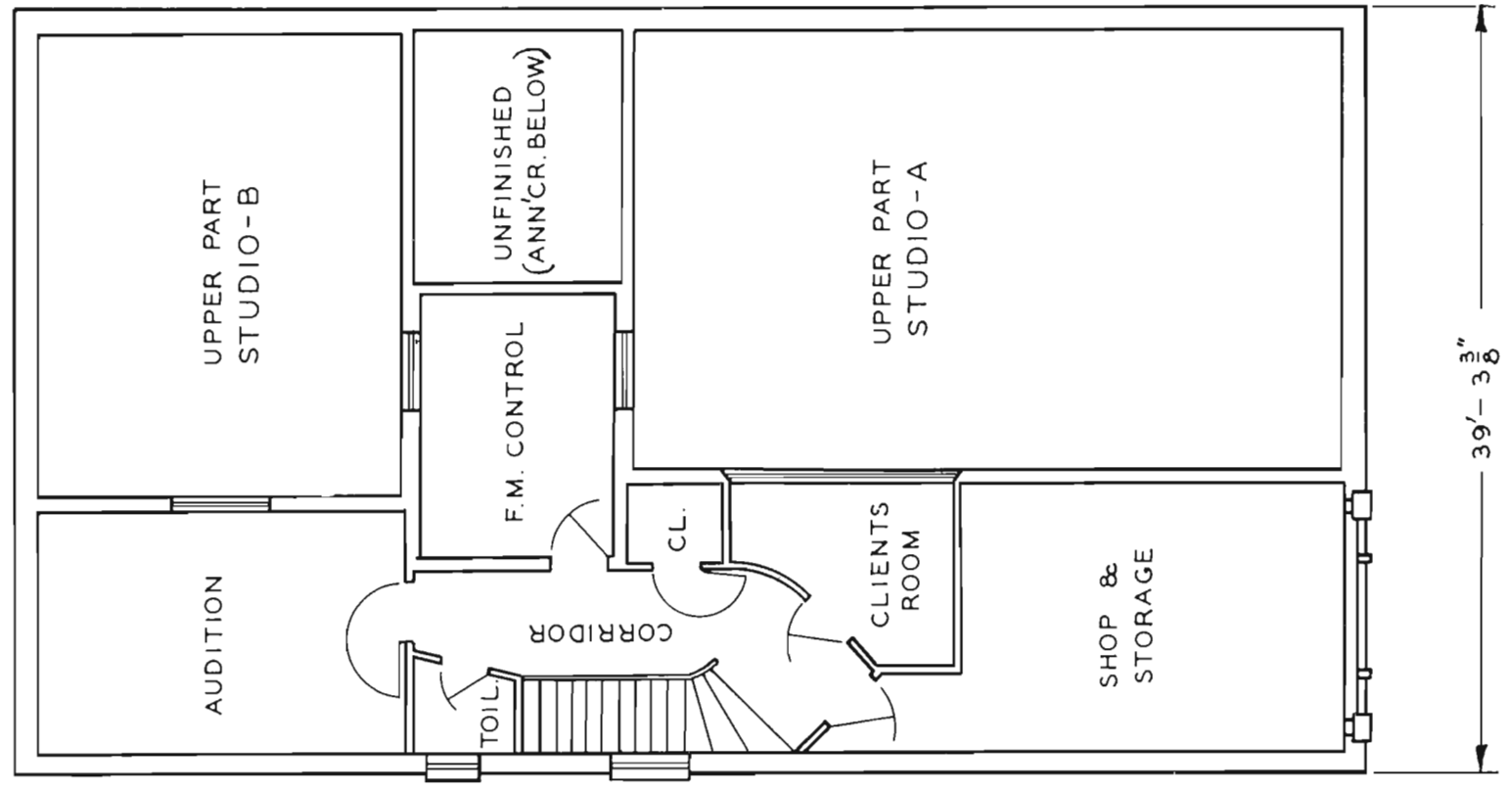

SECOND FLOOR PLAN

FIG. 5. Simplified plans of the first and second floors of the KTBS studio building. The two main studios are two stories in height. Between them are located two control rooms—one for AM and one for FM—which are perched on top of each other, so that both have windows looking into both of the studios. Thus either control room may be used with either studio in a completely independent manner. This makes it possible to schedule separate live programs on the two outlets—or to carry on full dress rehearsals in one studio while the other is on the air.



FIG. 6 (left). Interior of Studio A, largest in the KTBS group. Built to accommodate programs which require large casts, as well as live audiences, the studio will seat up to 75 persons. At top left is the studio's observation booth; at center are twin control rooms which sit atop each other; while at far right a partial view of the announcer's studio is shown. RCA 44-BX and 77-D microphones are used in the studios, 88A's in the control rooms.

FIG. 7 (below). This view, showing the other end of Studio A, is from the observation booth on the second floor. The glass in the windows at right (the windows from the entry foyer) is curved to match the curvature of the polycylindrical diffusers. Control room window glass is similarly curved to match the vertically placed diffusers on the end wall of the studio.



FIG. 8 (right). This is a corner of Studio B, a somewhat smaller studio designed for shows which do not require, or permit an audience. This studio, like Studio A, is finished on all four walls and ceiling with birchwood polycylindrical difusers. At the left, in this view, may be seen the windows of the twin control rooms which sit atop each other and look into both of the main studios (so that either control room may be used with either studio). The window at top right is in the "audition room" which also serves as a "clients' booth."

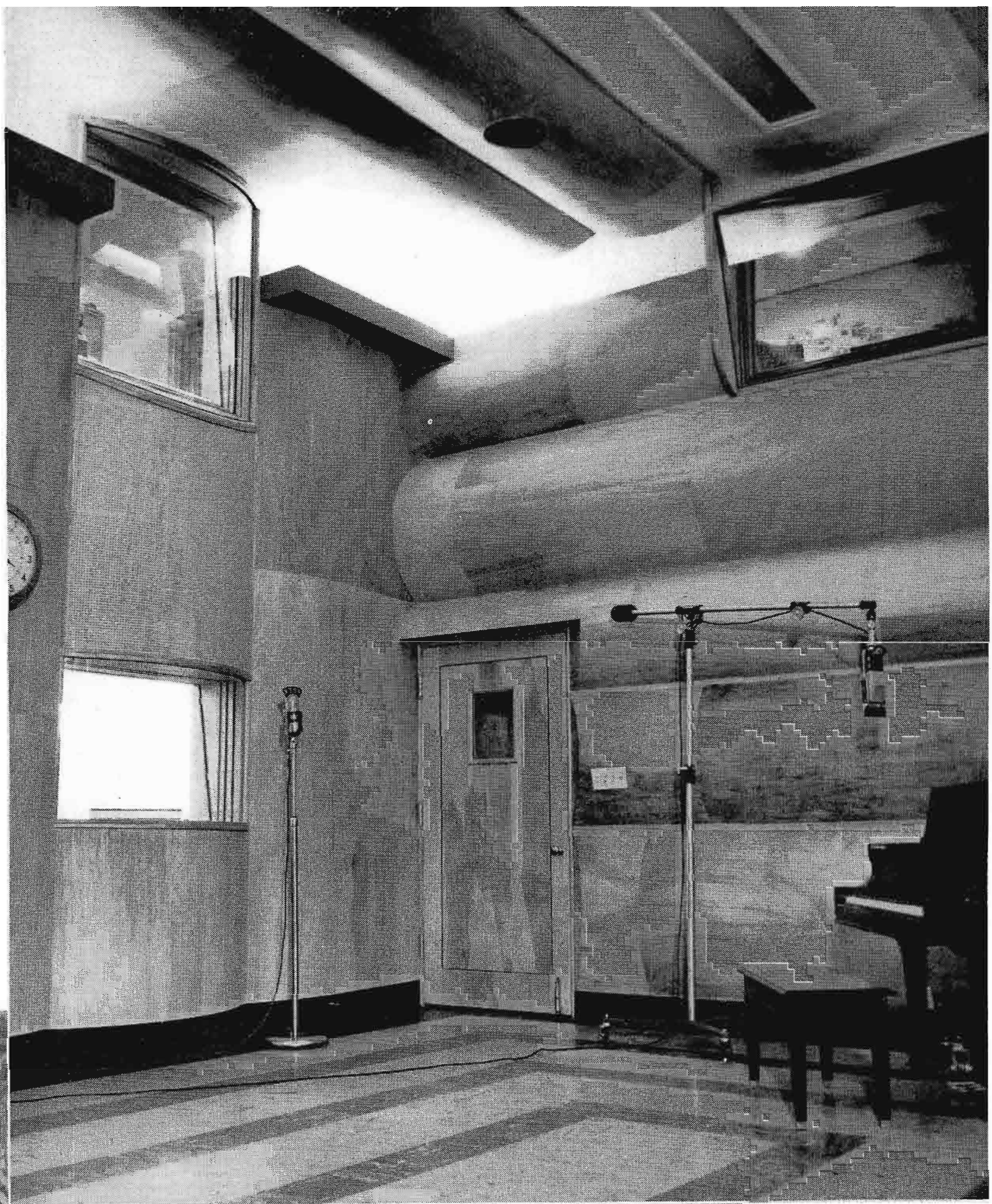

FIG. 9 (below). Located on the second floor of the new KTBS studio building is this luxuriously furnished "Audition Room." Overlooking one of the main studios, its occupants may see as well as hear programs in progress through a specially-constructed "observation" glass partition.

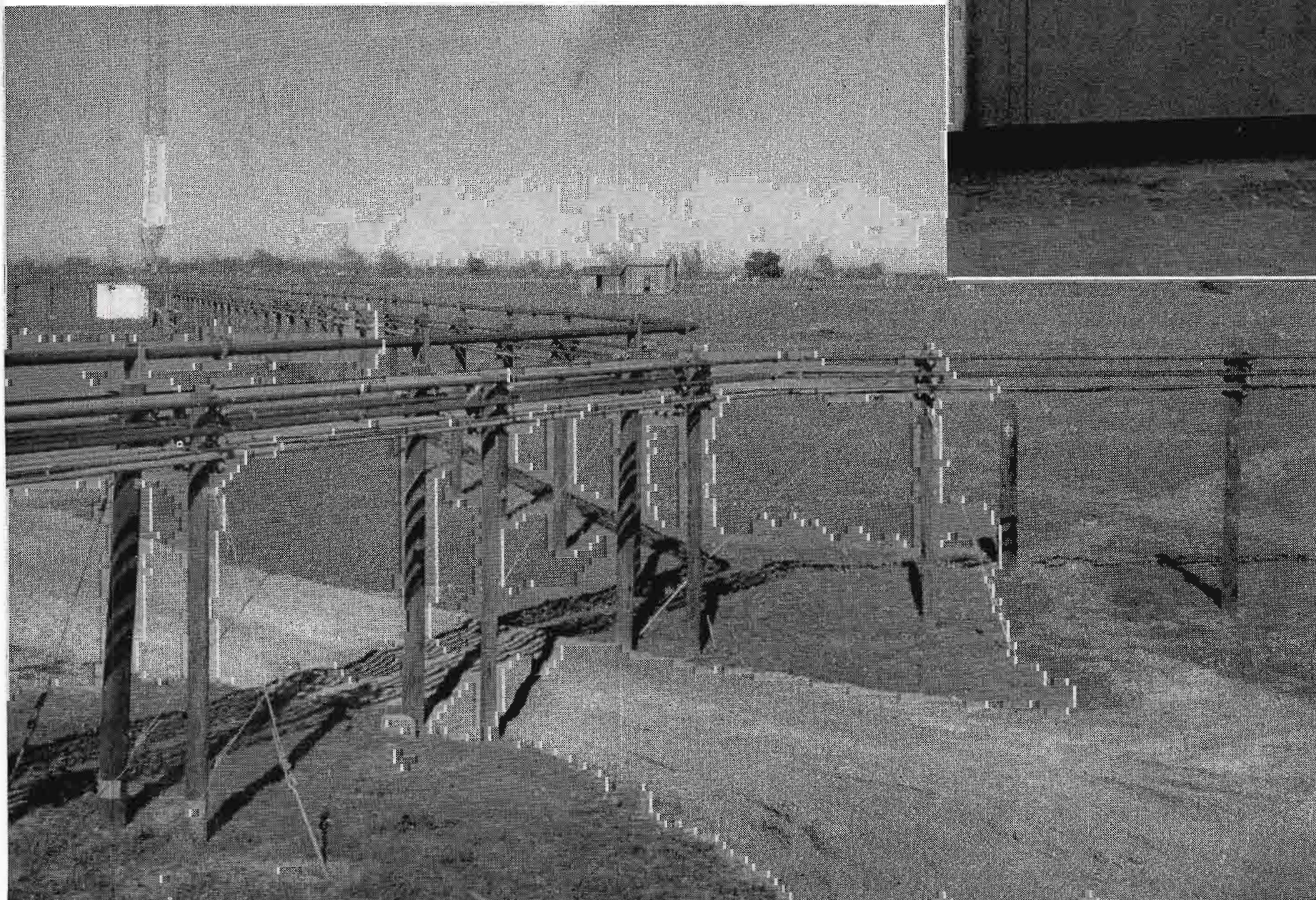
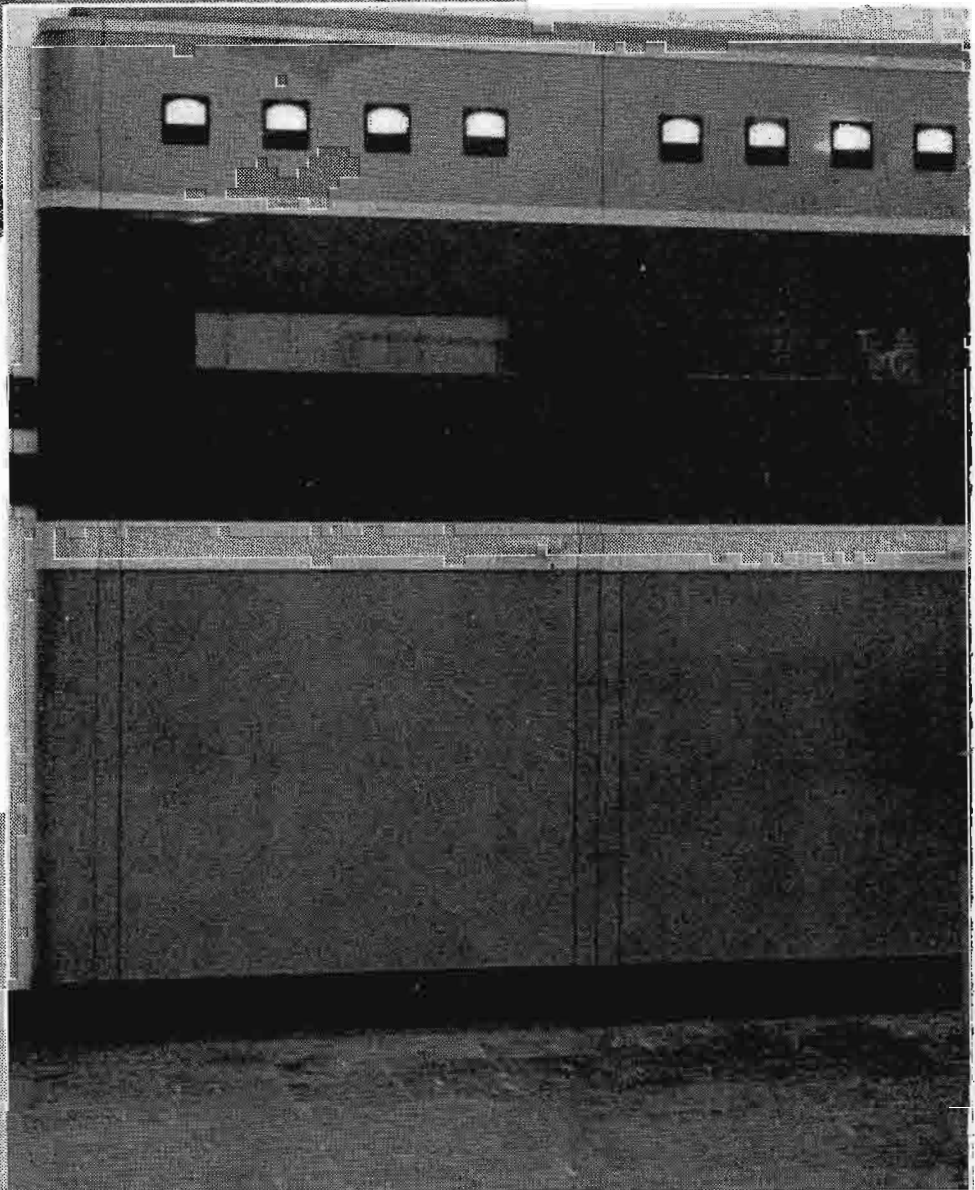



FIG. 1 (above). KTBS' new transmitter building is located 14 miles northwest of Shreveport. Floor of the fireproof building is five feet above ground level so that equipment is safely above possible flood waters.

FIG. 2 (right). KTBS' transmitter is an RCA Type 10-F operated at 10,000 watts day and 5,000 watts night. Phasing equipment is located behind the panel door at the extreme left of the main transmitter assembly. Monitoring and audio equipment units are mounted in racks built into the right-hand wall of the transmitter room.

FIG. 3 (below). Transmission lines feeding the six-element directional antenna array at KTBS are of the concentric type mounted on poles high above the ground. This view shows the point where the lines from the transmitter building branch off to the two halves of the array.



KTBS' NEW TRANSMITTER

Completely New Transmitting Plant Features a Six-Element Directional Array Designed and Constructed With Unusual Attention to Details of Feed Lines, Lightning Protection, Etc.

by W. M. WITTY

Broadcast Facilities Consultant*

EDITOR'S NOTE: The stability of a directive antenna system depends to a large degree on the care with which the antenna and ground system, the feed lines, and the phase monitoring equipment are installed. However, just being careful with ground leads, avoiding sloppy joints, etc.,

is not in itself sufficient. A considerable amount of know-how is required, if pitfalls are to be avoided.

The installation described in this article was supervised personally by Mr. Witty—a consult-

ing engineer of many years experience (see Page 49). The result is a beautiful example of what can be done when care and know-how are combined. Every station engineer facing the near future installation of a directive antenna should study it carefully.

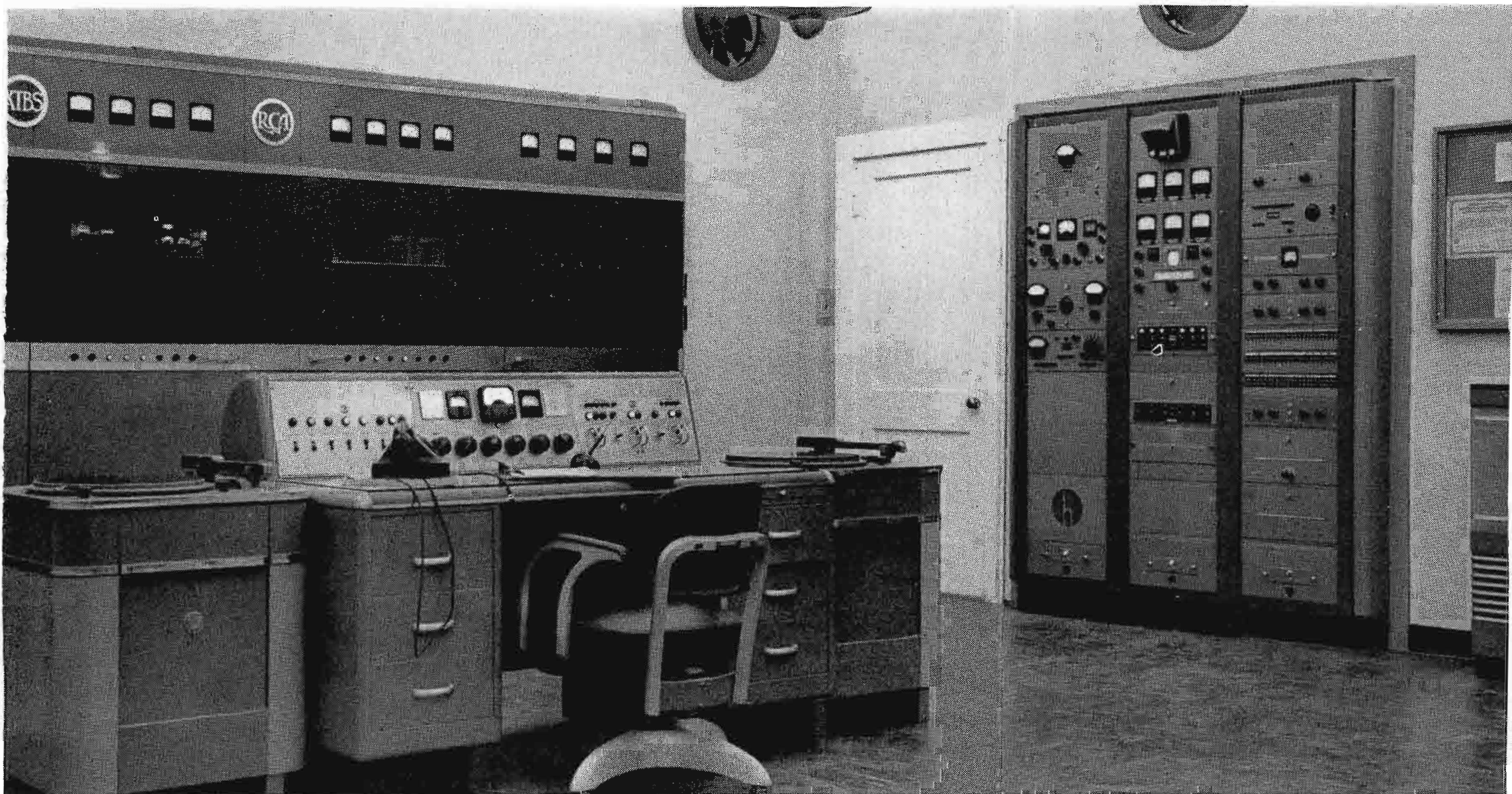

On Thursday, April 14, 1949 KTBS in Shreveport began operation with a new frequency and ten times more power. The new transmitting station operates on 710 kilocycles with a daytime power of 10,000 watts and 5000 watts at night. With these improved facilities, one of the pioneer broadcasting stations of the South will be able to serve better the progressive tri-state area of which Shreveport is the center.

*6923 Snider Plaza, Dallas, Texas.

The new KTBS plant is located approximately fourteen miles north-northwest of Shreveport and is situated in the heart of the cotton plantation country about one and one-half miles west of the town of Dixie, Louisiana. A fireproof transmitter building houses RCA's latest model 10,000 watt transmitter with associated equipment. The six element directional antenna system is an outstanding example of modern directional antenna engineering and construction.

Several months were required to build the new KTBS plant. In order to obtain a site that complied with the approval of the CAA and was satisfactory from the standpoint of pattern orientation, it was necessary to select a plot of land within relatively limited boundaries. As is quite often the case, the only site that was available was one not served by a main highway or any utilities. A dirt road leading to the site from a parish highway had to be covered with gravel before any



FIG. 4 (left). KTBS' plant engineers. Left to right: C. H. Maddox, Chief Engineer, N. F. Keyes, Charles Ellis, E. W. Cook, Fred Woodruff.

FIG. 5 (opposite page). KTBS' antenna system consists of six 378-foot guyed towers arranged in a line and spaced 530 feet between towers. The upper part of the No. 3 tower (third from left) is a four-section Pylon to be used for FM transmission. Four of the towers are used for daytime transmissions and all six for nighttime. Doghouses at the bottom of each tower contain phasing and matching networks, protective circuits, etc.

material for construction could be delivered. A branch power line was erected by the power company for supplying the necessary service. Special lines all the way out from downtown Shreveport were installed by the telephone company. Both power service and telephone lines were brought in underground for a considerable distance from the station in order to prevent their having any effect on the tuning of the directional array.

In view of the fact that the land on which the station is built has been covered by overflow water from the Red River and Caddo Lake on a few occasions during the past years, it was deemed advisable to take the necessary precautions to prevent recurrence of flood waters from damaging the station. The transmitter building was constructed with the floor five feet above ground level and all the tower foundations are eight feet high. The equipment in the tuning houses is mounted at eye level on the walls of the houses in "bread-board" style rather than in metal cabinets. In some of the tuning houses vertical panels mounted on upright steel beams located in the center of the floor supplement the wall panels. All transmission lines, lighting circuits, and interwiring between the transmitter building and towers is mounted on poles at least eight feet above the ground level.



FIG. 6. This is another view of the transmission line branching point. Because separate feed systems are used for day and night transmission there are two concentric lines to each tower. The large line at the top is the concentric line feeding the FM antenna at the top of No. 3 tower.

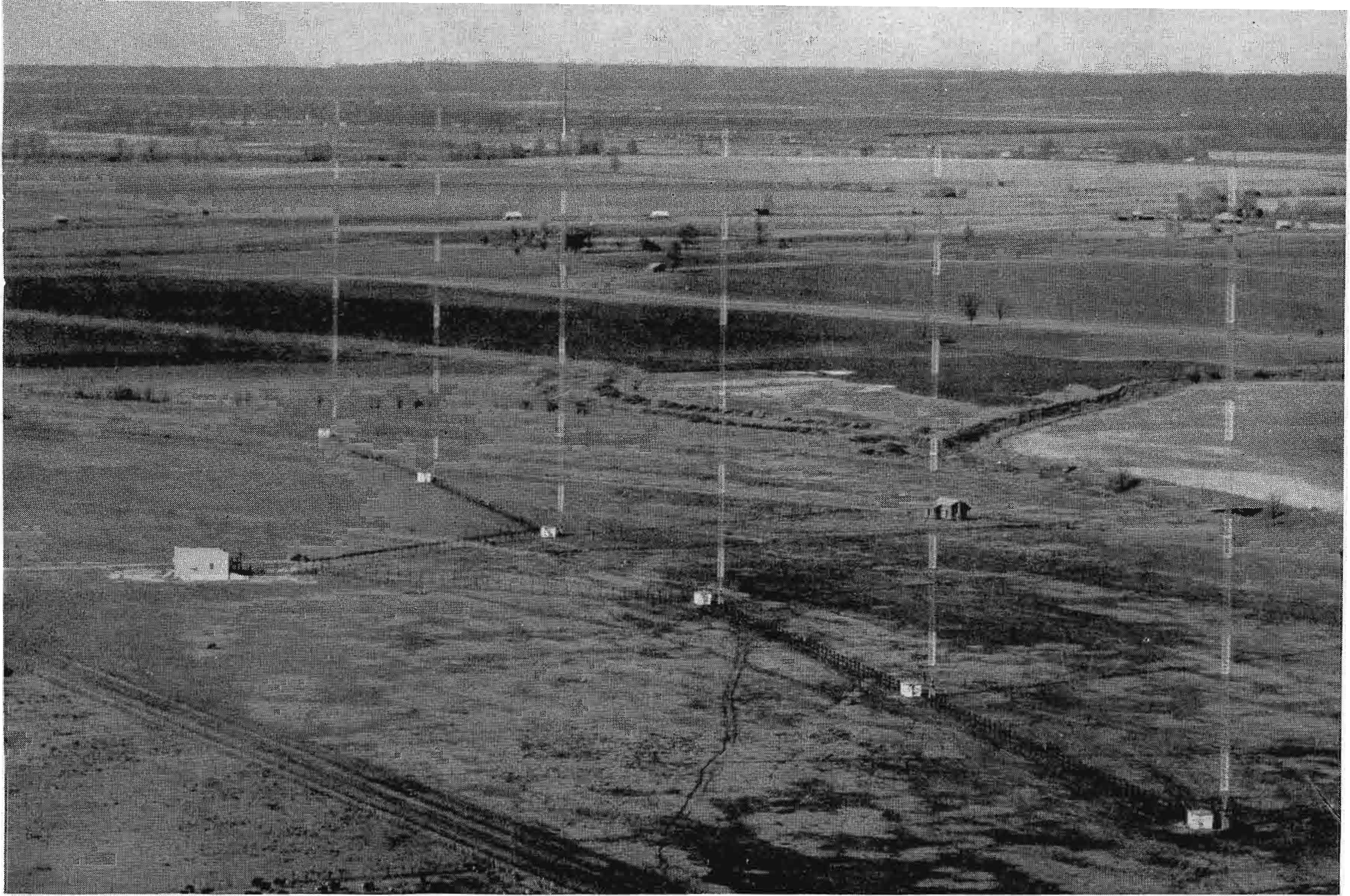

Antenna System

The directional antenna system for the new KTBS was designed and adjusted by the consulting firm of A. Earl Cullum, Jr. of Dallas. The array (Fig. 5) is a six tower "in line" type with four of the towers used for daytime operation and all six in service at night time. The towers are 378 feet high and spaced about 530 feet which means that the end towers of the array are approximately one half mile apart. The towers were furnished by the International Derrick and Equipment Company and were erected by the Andrews Company of Ft. Worth. A four-section RCA Pylon FM antenna was mounted on top of Number 3 tower. The combined height of this Number 3 tower and Pylon is 378 feet.

Since a rather "tight" pattern was involved the array was constructed according to a very rigid specification in order to obtain the highest degree of stability possible. Every precaution was taken to insure permanence of all joints, bonds and electrical connections. Mechanically all towers and ground systems are symmetrical with the exception of the one radiator

which is made up of a shortened tower plus the FM Pylon. All underground joints and all connections between heavy members above ground were made with silver solder or brazed and welded. In ad-

dition to the bond straps furnished by the tower manufacturer for "jumping" the butt joints on the towers the lighting conduits were bonded to the towers at 10-foot intervals throughout the tower lengths.

ABOUT THE AUTHOR

W. M. (BILL) WITTY, the author of this article, needs no introduction to most readers of BROADCAST NEWS. For nearly twenty years he has been intimately associated with the broadcasting industry in the southwest—first as RCA's field sales engineer for the area, and more recently as a consulting engineer in his own right. Leaving the perhaps more glamorous field of allocations engineering to others, Bill has specialized in "facilities engineering"—i.e., the planning and supervision of plant installations, particularly those involving complicated and extensive antenna or equipment problems. The KTBS transmitter plant was one of these. The accompanying article—printed in Bill's own modest words—makes no attempt to glamorize this job. However, BROADCAST NEWS readers familiar with this type of installation will quickly recognize it as the work of an expert.

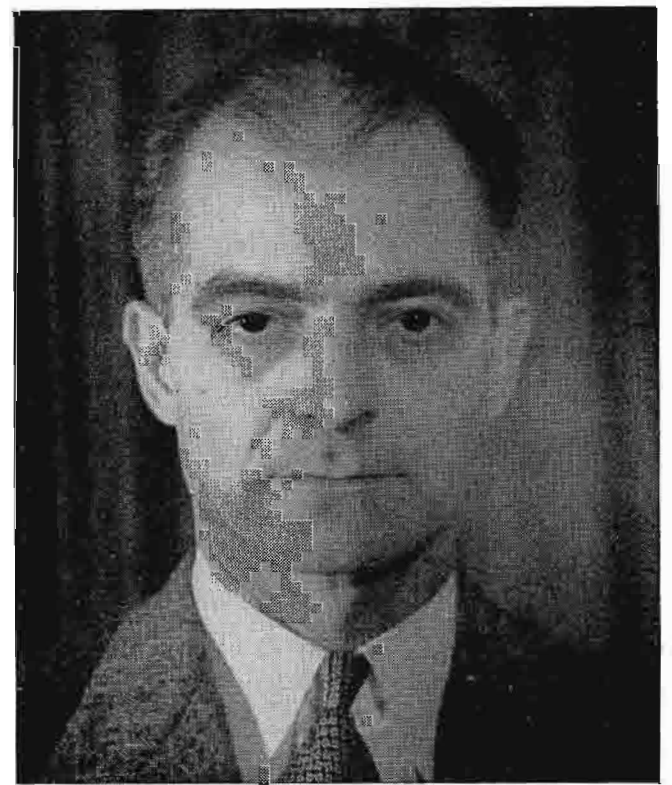

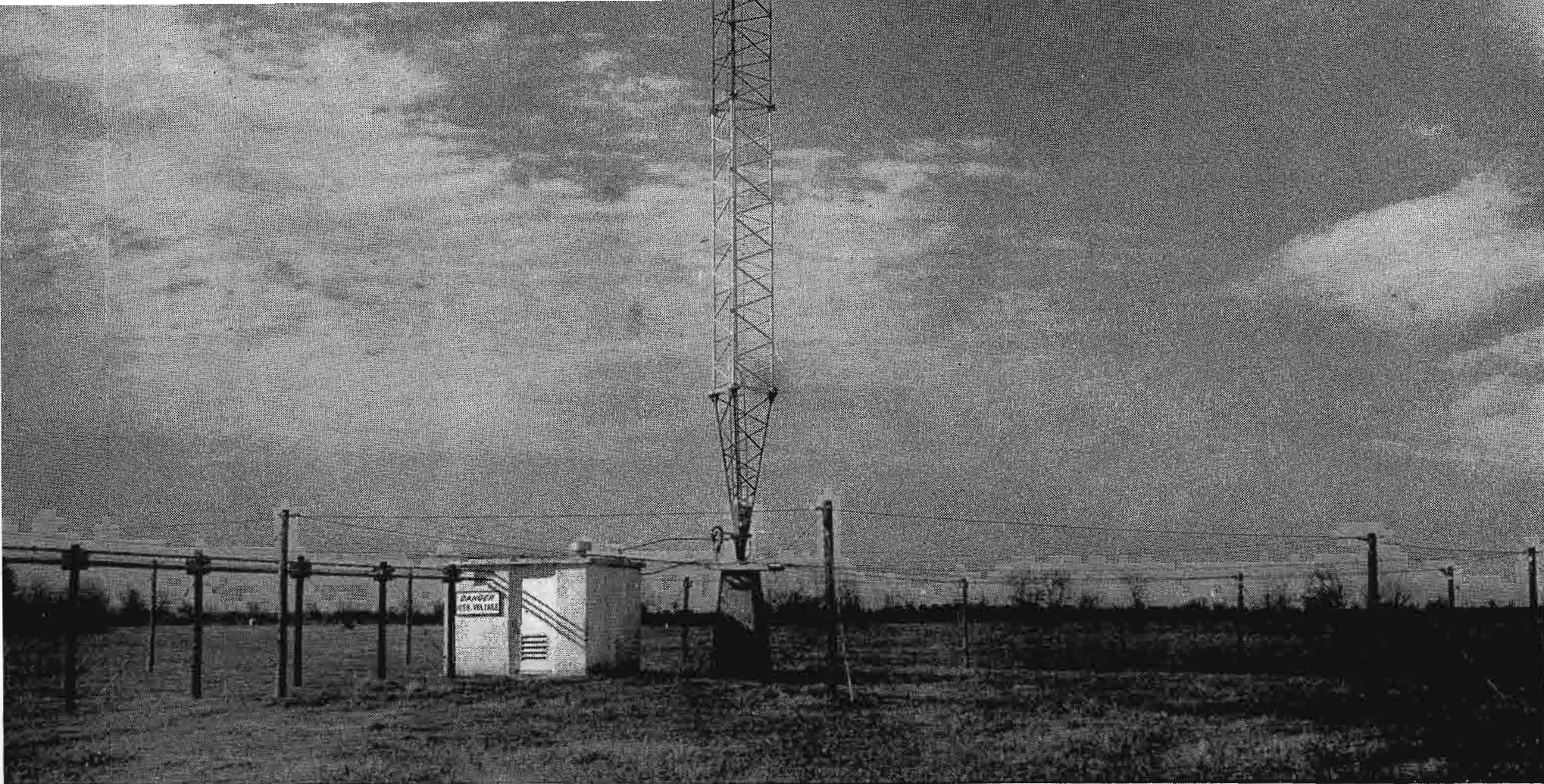

Ground System

The type of ground system installed at KTBS, to some extent, departs from the conventional form of buried radial system. The KTBS ground system does have 120 buried radials 300 feet long around each tower, but these do not come all the way in to the tower base insulators. Rather, these radials terminate at an underground circular bond strap 100 feet in diameter around the edge of the overhead system. The overhead system (Fig. 7) is supported by anchored poles—12 at each tower—and is 8 feet above the ground level. It consists of 120 radials drawn tautly and

soldered between a central ring (Fig. 8) mounted around the top of the tower foundation and a large copper cable supported by the twelve poles (Fig. 9) around the 100-foot circle. This outer cable is, in turn, bonded to the underground circular bond strap by means of 4-inch copper strip running down and tacked to each pole. Since the tuning houses are beneath the ground system, connections to the tuning house equipment from the ground system, as well as from the antenna, are made through the roof of the tuning houses.

This type of design insures maximum stability of antenna impedance since there

can be no foreign material of changeable nature such as vegetation, water or soil within the field of the antenna at the point which is most critical and where the current is highest.

The individual tower ground systems were connected together by means of a buried 4 inch copper strip running the full length of the array. Also transverse 4-inch copper strips were placed at halfway intervals between all of the towers and any ground radials that were traversed were silver soldered to these strips. The central transverse strip extends to the transmitter

FIG. 9 (below). Close-up view of one of the anchored poles supporting the overhead ground screen. Note compression spring which provides compensation for expansion due to temperature changes.

FIG. 10 (below). This is a close-up view of the central ring to which the 120 radials of the elevated ground screen are carefully braised. The ring, in turn, is connected by copper straps to the bonding about the tower base.

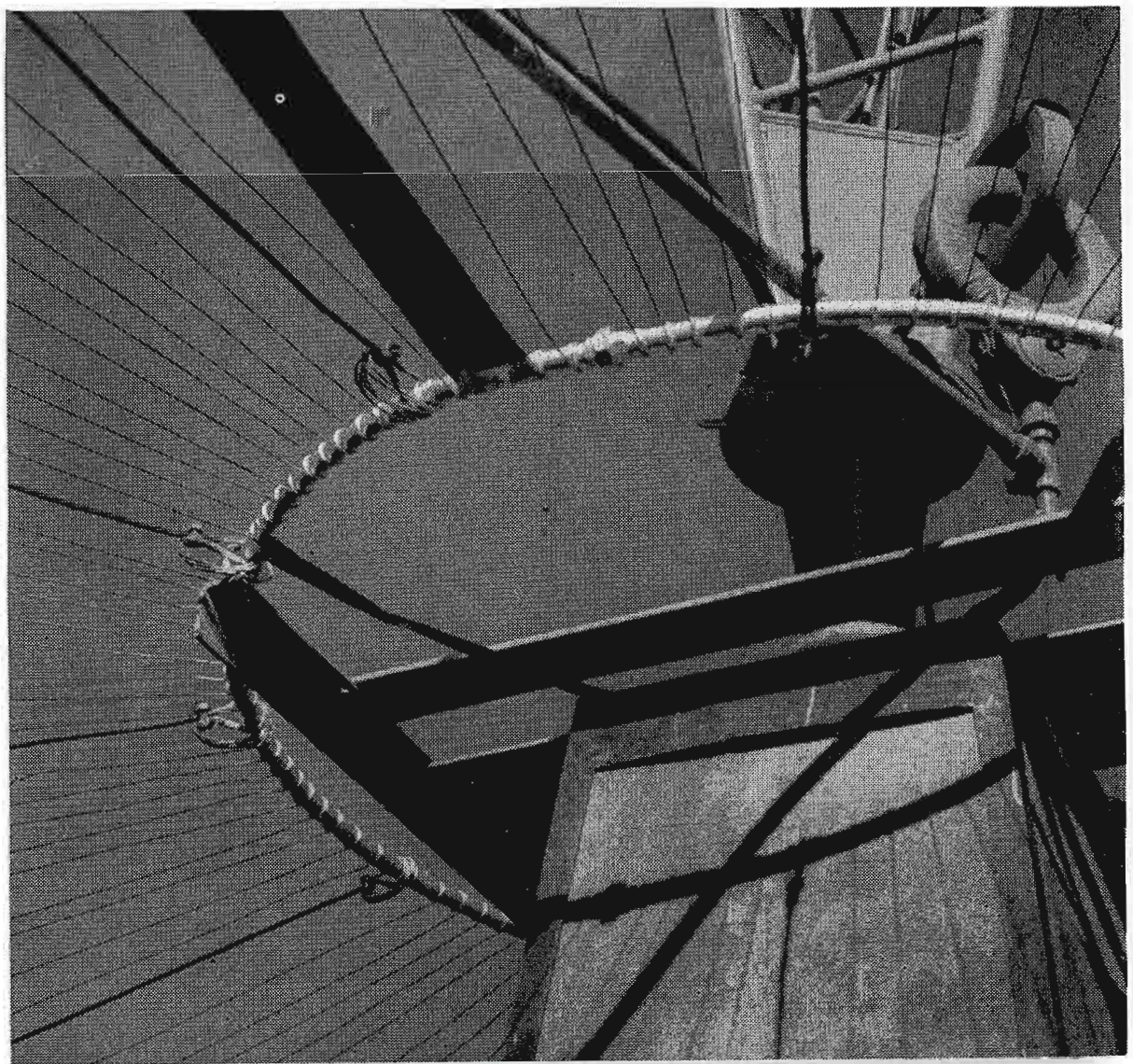
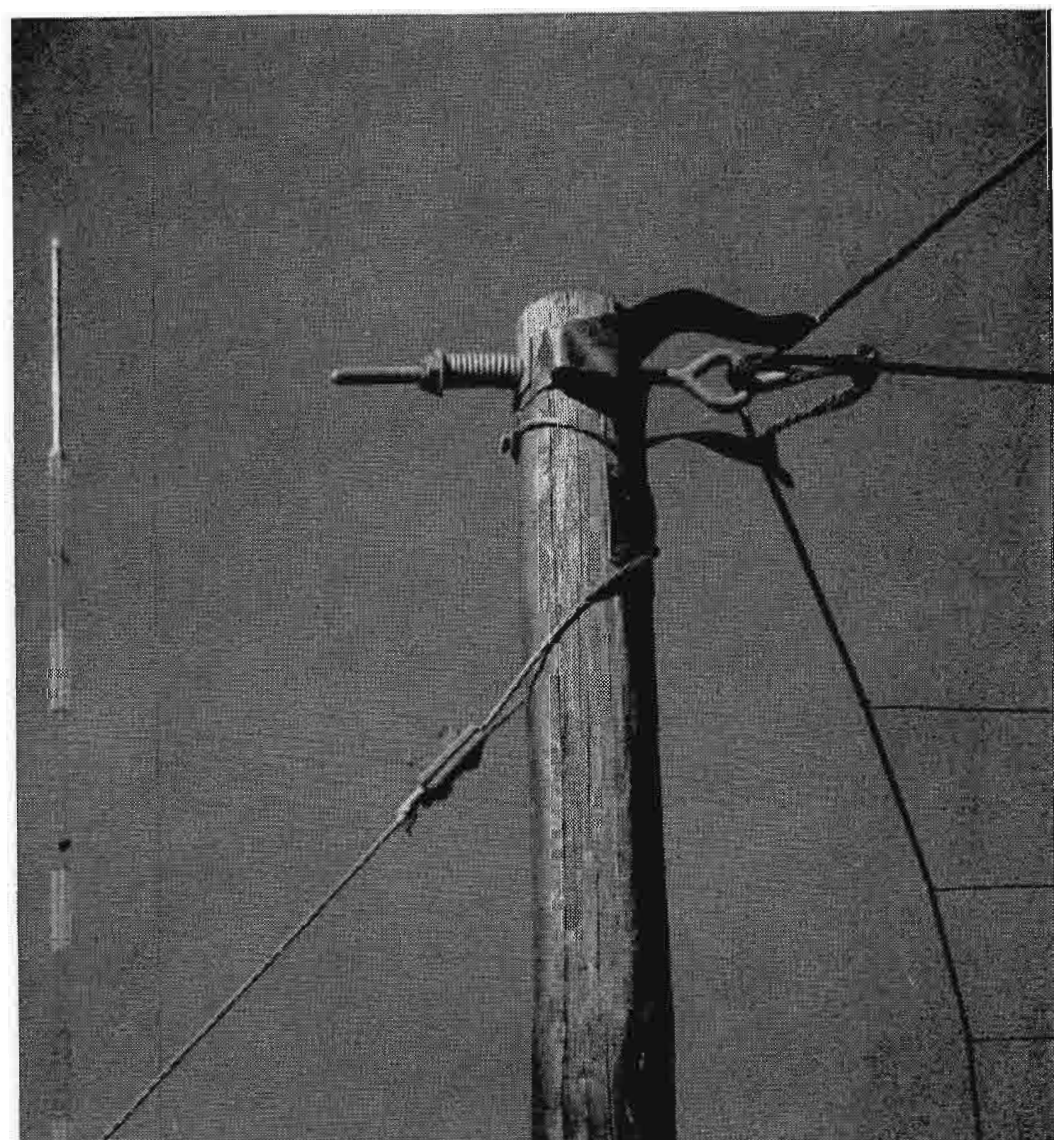

FIG. 7 (opposite page). Overall view of the elevated ground screen installed around each of the KTBS towers. This arrangement provides a stable antenna impedance because changes in vegetation or ground water in the critical area around the base are minimized.

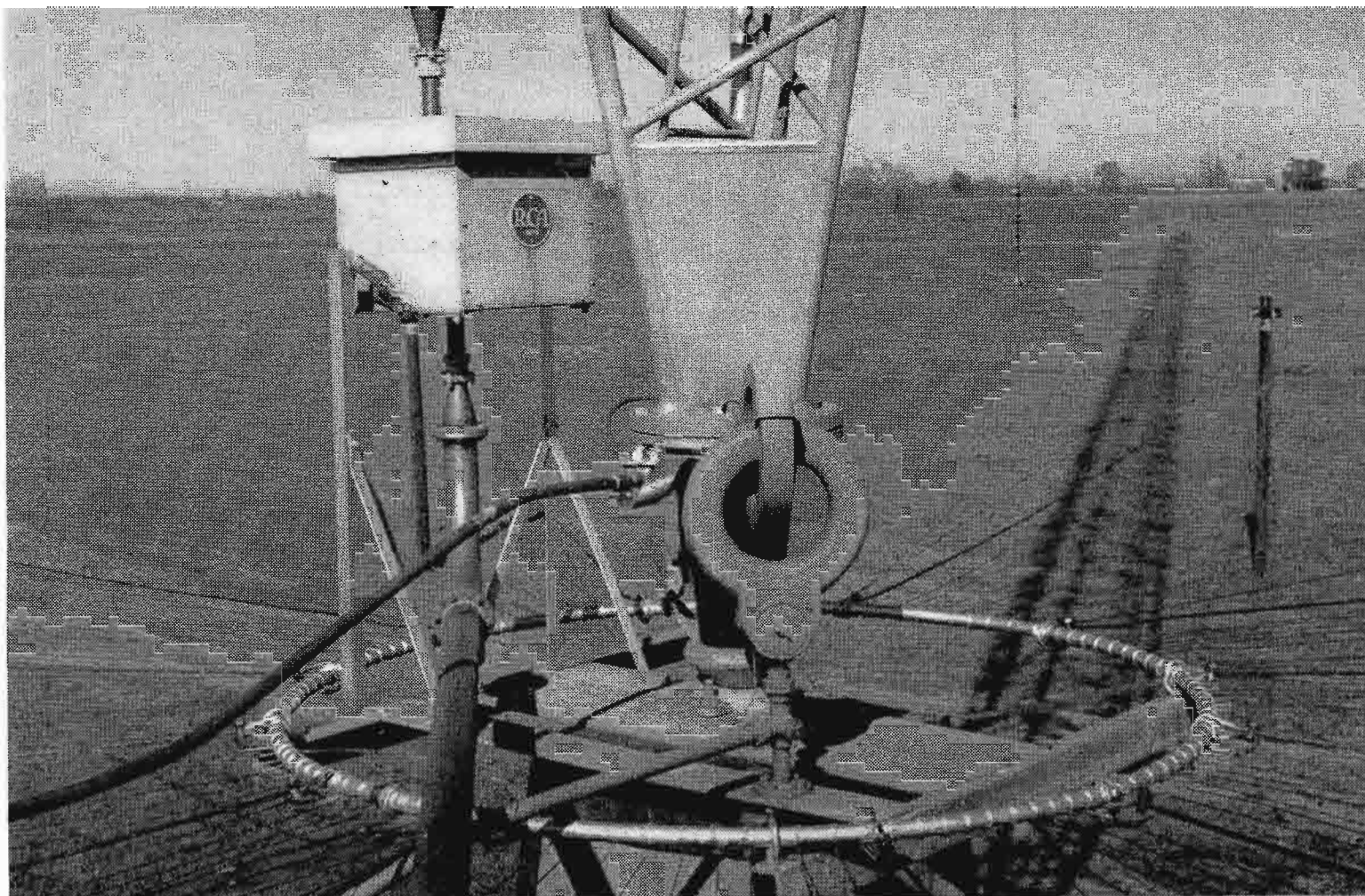

FIG. 8 (right). This close-up view of the base of one tower shows the BAF-4A FM Isolation Unit (in square box) and the Austin Transformer (large open coils) used to isolate the tower lighting circuits.

building and is connected to the ground terminals of all the transmitting equipment.

Other copper strips were buried along the line of transmission line poles between the transmitter building and towers Number 3 and Number 4. All transmission lines, conduits, and sampling lines were bonded to these buried strips at each pole, which are spaced at 10-foot intervals. Along the runs between the towers these ground connections are made at 30-foot intervals.

Tower Lighting System

In many directional antenna systems the 1000 watt beacons mounted on each

tower in accordance with CAA requirements are flashed by means of individual flashers of the non-synchronous type installed on each tower. The speed of the motor in this type flasher varies a slight amount with the result that the lights on a multi-element array occasionally get "in step". If this occurs with as many as six elements a rather heavy demand is made on the power service and the line voltage will fluctuate to the extent that it is sometimes difficult to operate measuring equipment in a station during nighttime hours.

At KTBS a central flasher was installed in the transmitter building and the three

phase power service divided among the six towers in such a manner that a nearly constant lighting load is presented at all times. The flasher consists of a synchronous motor geared to rotate a cam shaft at 36 R.P.M. Six adjustable split cams are mounted on the shaft and arranged to operate individual mercury type switches that control the lighting voltage to each tower. This arrangement enables the desired lighting sequence of the towers to be obtained and the split cams permit accurate adjustment of the 2:1 light-to-darkness ratio required by the CAA.

FIG. 11 (below). This view of the tower base shows the connections between the tower and the doghouse (lower right corner). The large concentric line is the FM feed line which runs directly to the BAF-4A Isolation Unit in the square box at the top left of this picture. Note that the isolation unit is mounted on springs in order to provide for differential expansion of the FM line which runs up the tower.

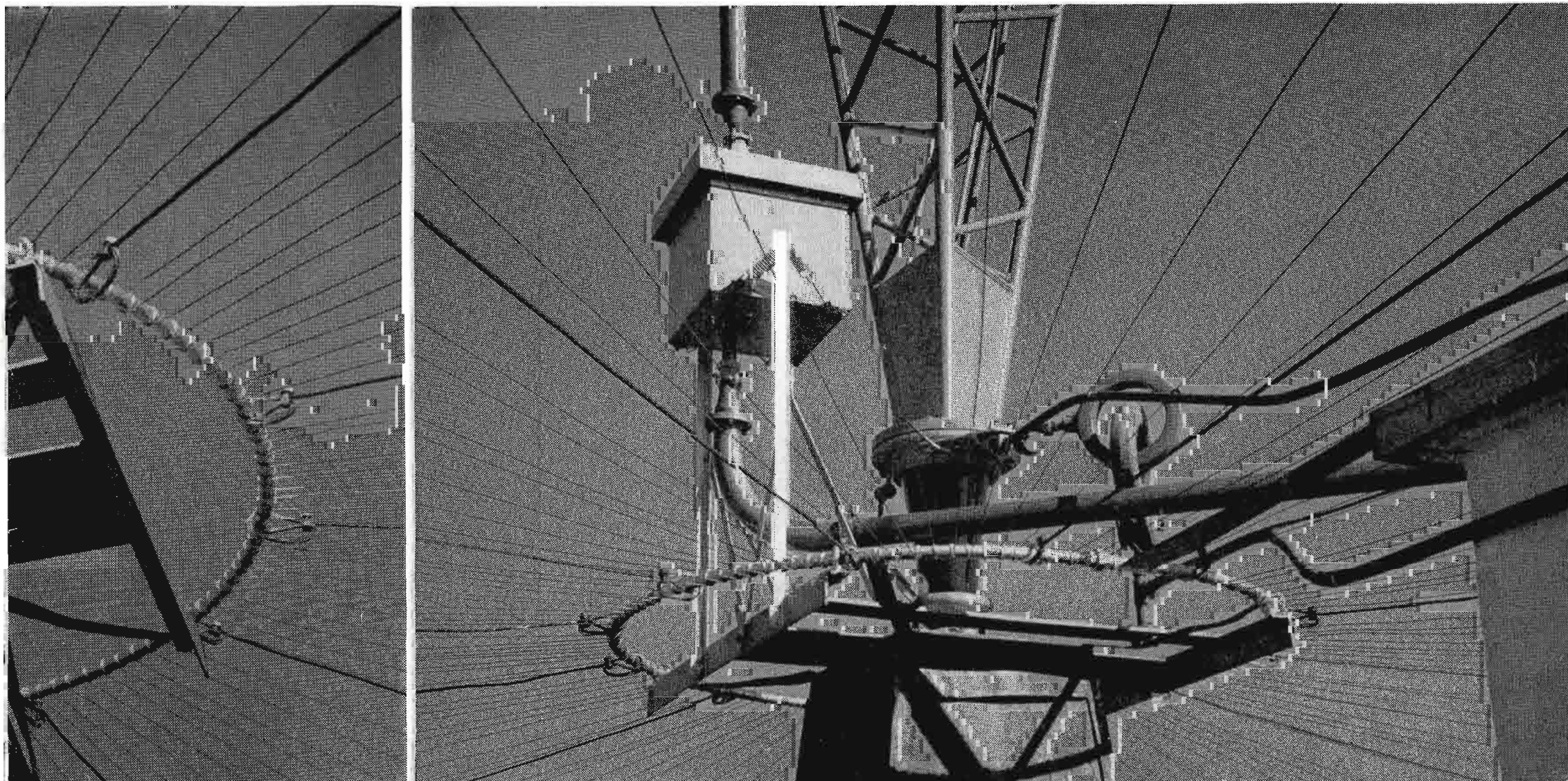

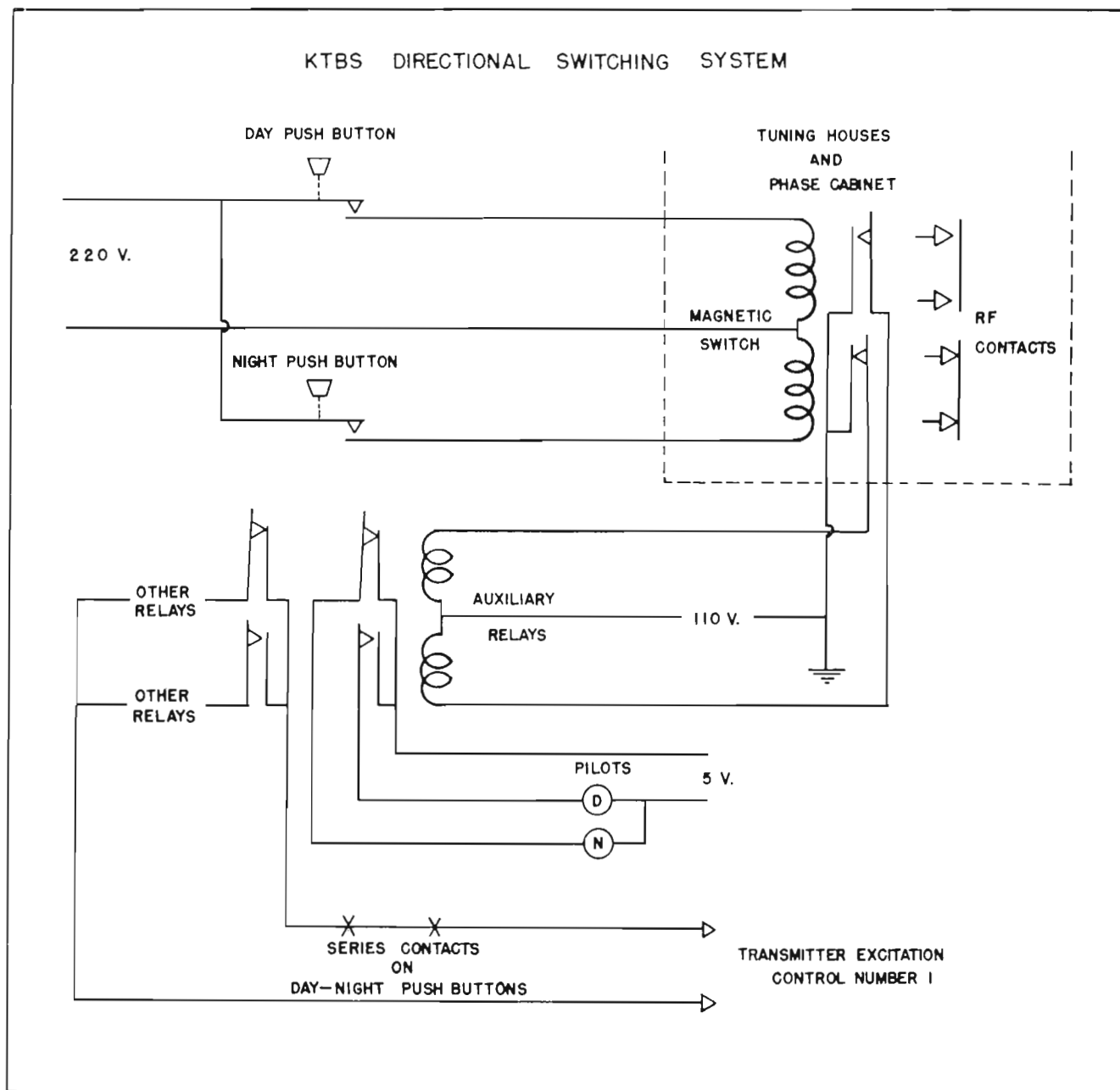

FIG. 12 (left). Simplified schematic of the KTBS directional switching system. Push buttons on the phasing cabinet operate contactors in the phasing cabinet and in the six antenna tuning houses. Back contacts operate signal lights in the transmitter room and prevent excitation from being applied until all contactors have closed.

Directional Switching System

KTBS's directional system consists actually of two separate and complete systems, so far as phasing and power dividing equipments are concerned. The daytime pattern is obtained with one set of networks, transmission lines and four of the six towers. The nighttime pattern utilizes another set of networks, lines and all six of the towers. Switching between the two modes of operation twice each day is accomplished by means of solenoid type switches located in each of the tuning houses and in the phase cabinet in the transmitter building (Fig. 12). Seven of these switches are actuated from two push buttons located on the front of the phase cabinet in the transmitter building. Each of the seven switches is provided with back contacts which actuate auxiliary relays in the transmitter building that have one set of contacts to operate pilot lights and another set to close the transmitter excitation control circuit. Extra series contacts on the push buttons also break the transmitter excitation control circuit. The excitation control in this instance is the plate supply to the transmitter crystal oscillator.

With this arrangement it is virtually impossible to switch the antenna system with carrier power "on". Also if one of the remote solenoid switches fails to go over its pilot light will indicate in which tuning house the trouble is and it is not possible to put the carrier back on until this switch has properly closed. All of the switches must be in one of the two positions—that is—day position or night position before carrier power can be restored. The operator is able to manually hold off excitation until all lights are on for one position, thus indicating that the remote switches are all clear. Should he inadvertently release the push button before all of the switches have cleared the auxiliary relays will prevent excitation from being restored.

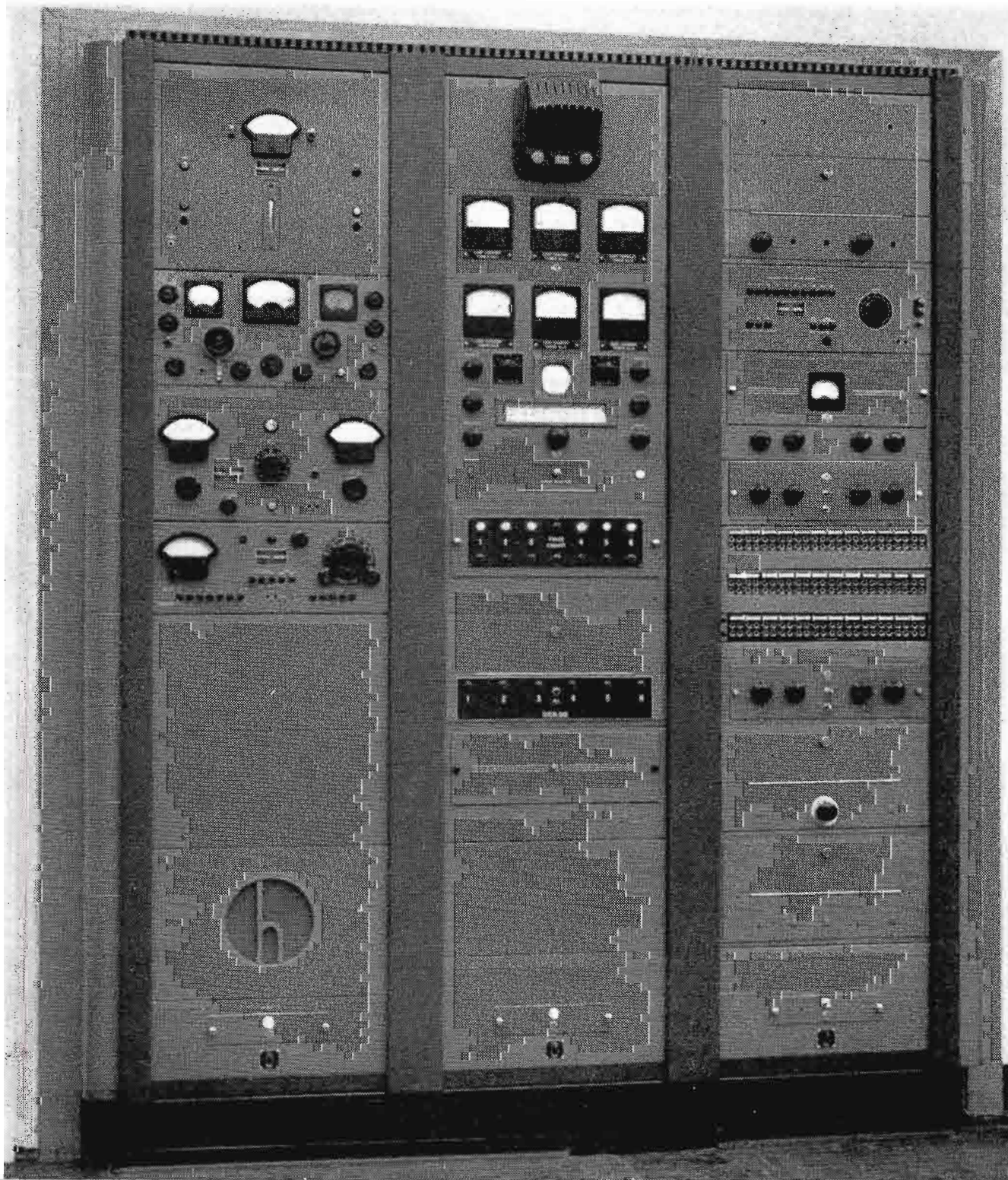

FIG. 13 (left). These three racks are built into the right wall of the transmitter room. The left-hand rack contains frequency and modulation monitors and distortion measuring equipment; the center rack the antenna meters, the phase monitor and the contactor signal lights; the right-hand rack contains the audio input equipment.

FIG. 14 (right). Simplified schematic of the novel lightning protection system installed at KTBS. A separate receiver-amplifier unit picks up radiation from each tower. In case of an arc-over on a tower, the reduction in signal picked up by the receiver-amplifier coupled to that tower will operate a relay which quenches the carrier for 250 milliseconds, thereby interrupting any tendency for the arc to become self-sustaining.

Lightning Protection System

Since the station uses a large amount of coaxial line, it was felt that in rather long runs some protection system for eliminating possible arc overs, in the line and tuning house equipment due to lightning hits, was essential. The lengths of line together with the associated equipment are such that it might be possible for an arc to be sustained without reflecting a power overload that would trip the protective relays in the transmitter.

A lightning protection system (Fig. 14) was installed that consists of six receiver-amplifiers, a power supply and set of six relays. Each of these receiver-amplifiers is excited from the field of one of the towers and actuates one of the relays. These relays have their contacts connected in series and also in series with a transmitter excitation control circuit provided in the transmitter. Also they have contacts to operate pilot lights indicating in which tower a change in current has occurred. The excitation control in this case is in the form of a high negative charge applied to the grid of the first RF amplifier in the transmitter which quenches the carrier for about 250 milliseconds. With this arrangement, an arc over in any of the tuning houses will momentarily stop the carrier without de-energizing the high voltage plate contactors. Should the arc continue or if a component had failed which will cause one of the towers to cease normal radiation the transmitter will be shut down at the end of one second.

These receiver-amplifiers contain four tubes arranged to provide a coupling stage, one tuned stage, a diode rectifier, and a DC amplifier to actuate the relay. This combination provided sufficient gain to enable the receivers to be excited by a very high impedance connection across the 70 ohm sampling line from the tower it serves.

Also the tuning of one stage provides ample selectivity to prevent the receiver being affected by adjacent radio stations, shock excitation, etc.

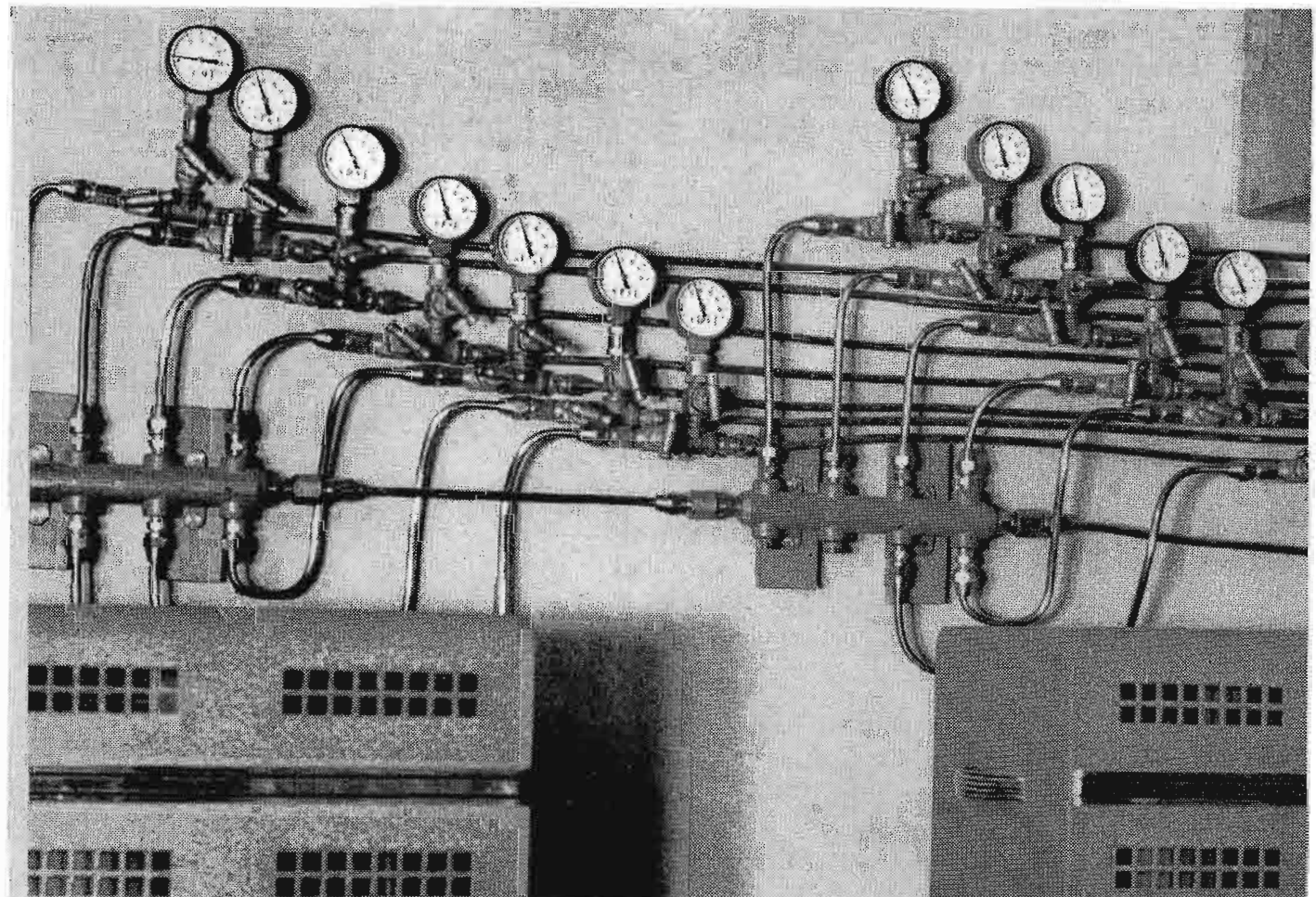
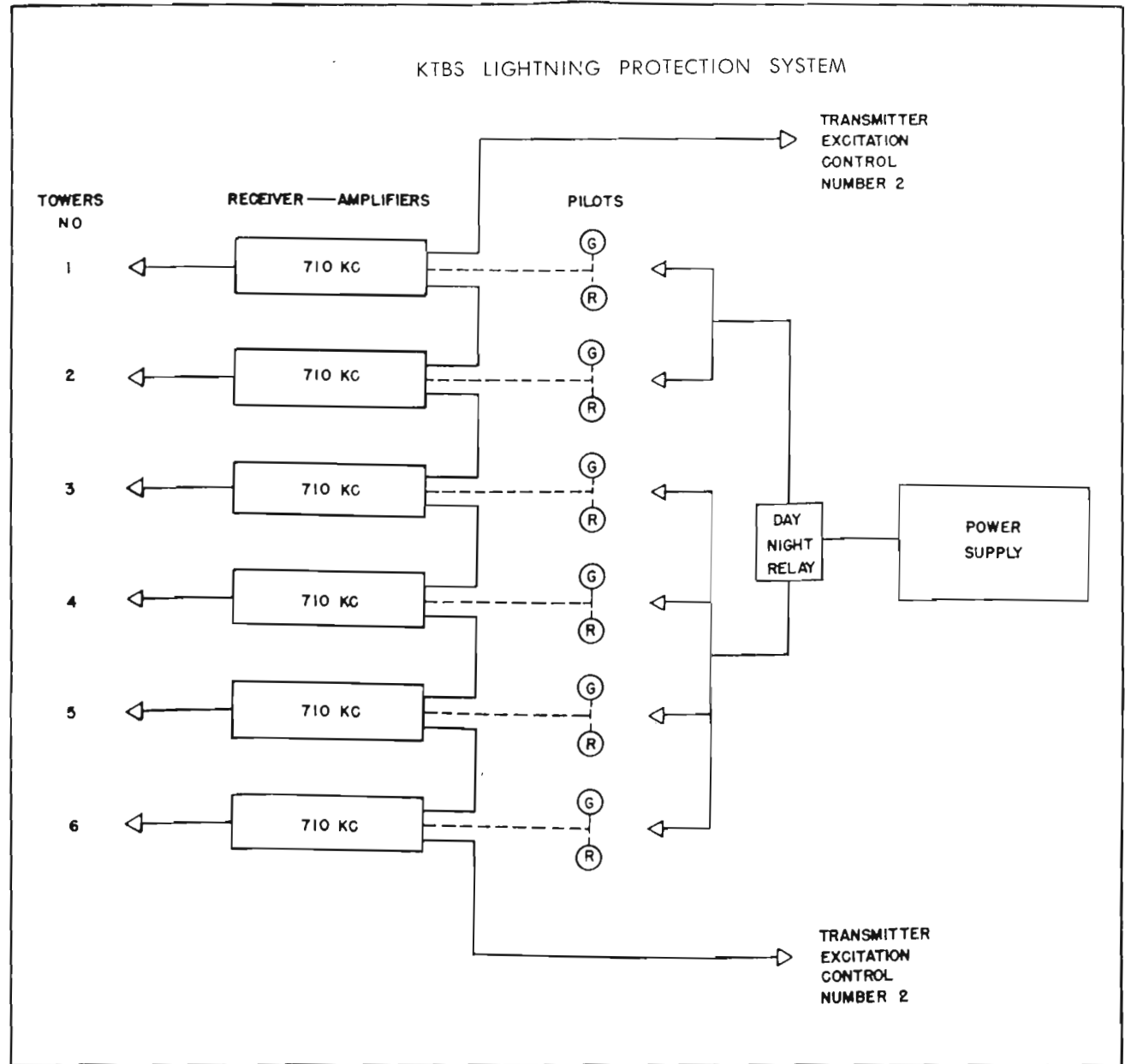

FIG. 15 (right). A dehydrated air distribution system with individual gages and valves was installed to feed the 13 concentric transmission lines at KTBS.

KAKE . . . 250W AM

Wichita, Kansas

By HAROLD H. NEWBY
Chief Engineer

KAKE Broadcasting Company, Inc., went on the air in September, 1947, on 1490 KC and later changed frequency to 1240 KC. The entire station installation (right from the purchase of land and leasing of studio space) was completed in less than 60 days. This performance may be attributed not only to construction and preliminary planning, but also to excellent operation of equipment employed.

Transmitter and Antenna

The transmitter plant, which is situated at some distance from the downtown studios, is shown in Figs. 1, 2 and 3. KAKE's tower installation consists of a 340 foot antenna (a half wave for the original frequency of 1490 KC). Also employed is a comparable ground system consisting of 120 radials, 330 feet long. The antenna now figures .43 wavelengths at 1240 KC. The overall antenna system, plus a near maximum soil conductivity for this region, gives KAKE a remarkable signal for a 250 watt station.

KAKE's 250 watt transmitter (RCA Type BTA-250L) is installed adjacent to audio, monitoring and test equipment racks (see Fig. 1). The transmitter desk console is located as shown in the floor plan of Fig. 2 in order to provide a convenient operating arrangement. The station employs a 10 KW stand-by emergency power unit which, incidentally, kept KAKE on the air during a severe storm in 1947 when primary power was interrupted to all stations in the area.

Studio Equipment

KAKE studios, which are located remote from the transmitter plant, are acoustically treated by Johns-Mansville. Studio programs are controlled from a centralized control room in which a control console, mikes and turntables are installed. Also included in the control room are two audio equipment racks, recording amplifiers, recorder, record storage space and an RCA 45 r.p.m. player. In addition, RCA 44-BX and 74-B microphones and stands are employed as standard studio equipment.

FIG. 3. KAKE's transmitter plant is a one-floor, brick-constructed building occupying a space of only 24' x 29' (approximately). Antenna tower is visible at right.

FIG. 1. KAKE's 250 W transmitter, RCA Type BTA-250L, is installed next to monitoring, test and audio equipment racks for convenient grouping.

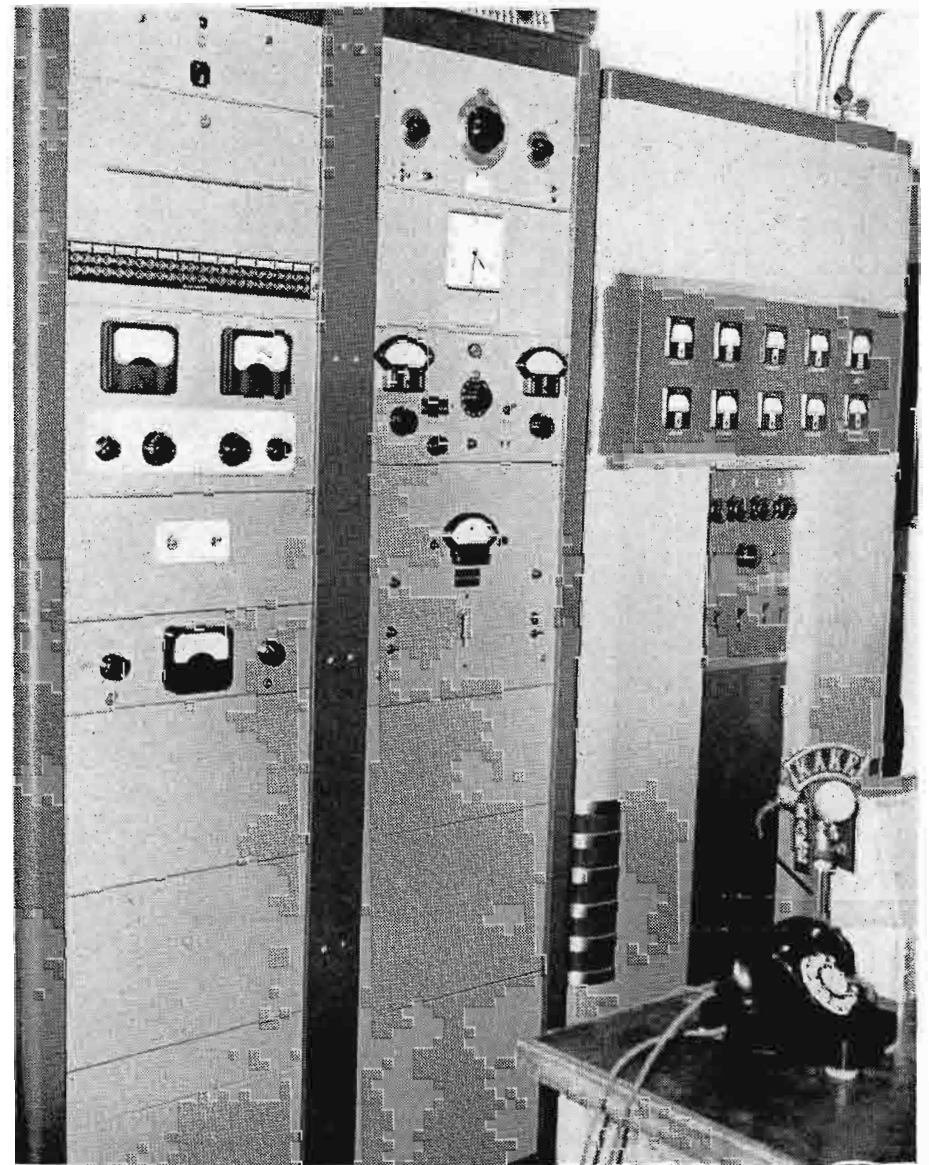
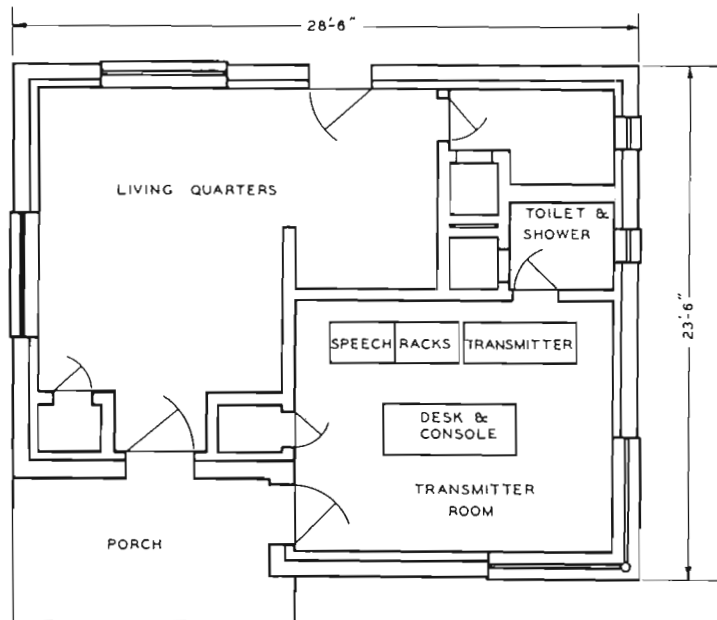

FIG. 2. Floor plan below shows the location of transmitter building components. Note that living quarters are provided.



By **ROGER L. SPAUGH**
Chief Engineer

250W AM . . . KOOS

Coos Bay, Oregon

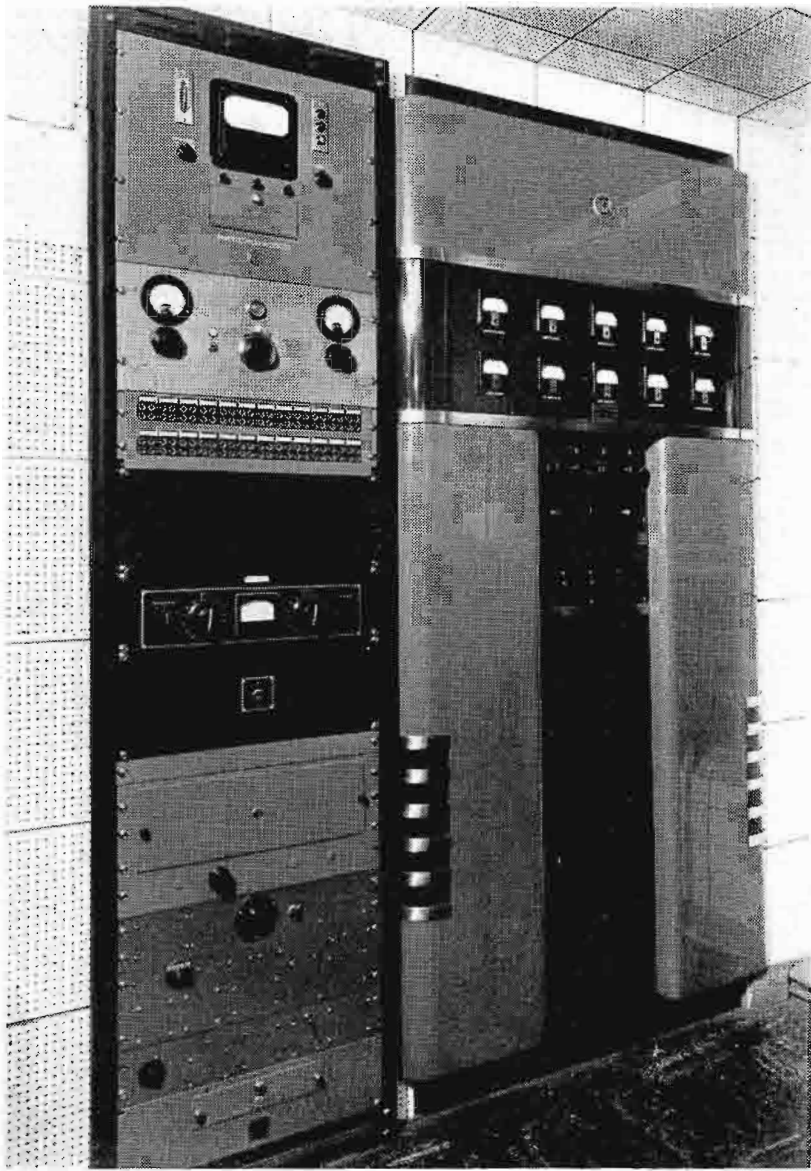

FIG. 1. Transmitter and monitoring and test rack are both flush-mounted in a wall of the Hall Building's fifth floor.



FIG. 2. As shown below, the KOOS tower is installed atop the Hall Building.

KOOS, originally a composite station, now operates with a new RCA 250 watt transmitter, type BTA-250L. All station equipment (transmitter, antenna and studio) is located in the "Hall" building (5th floor) of downtown Coos Bay. Tentative future plans include increasing power to 1 KW by the addition of a 1 KW power amplifier. In this event, transmitter equipment would be moved out of town and studios retained in the Hall building.

The KOOS antenna tower and counterpoise system is installed atop the Hall building, as shown in Fig. 2. The KOOS 250 W transmitter is flush-mounted in one wall, adjacent to the transmitter monitor, test and speech equipment rack (see floor plan of Fig. 3). Rear access to the transmitter and monitor rack is provided from the record room. In the one-floor KOOS layout, equipment is oriented so as to provide the operator complete access to all transmitter and studio controls, recorder and turntables. Visibility into the studio is provided from the operator's control position.

Studio control equipment consists of a composite 5-channel console, two RCA 70-series turntables, monitor speaker, monitor amplifier and turntable preamps. An RCA type 72 recording attachment is used on a third turntable (turntables and recorder have been in daily use for over 8 years and are still giving satisfactory service). In addition, KOOS uses 6 RCA microphones for studio and remote use. Tape recorders are frequently used on remote service and for some local programs.

FIG. 3. The one-floor KOOS layout provides the operator access to all station units, transmitter, monitor, and studio control functions.

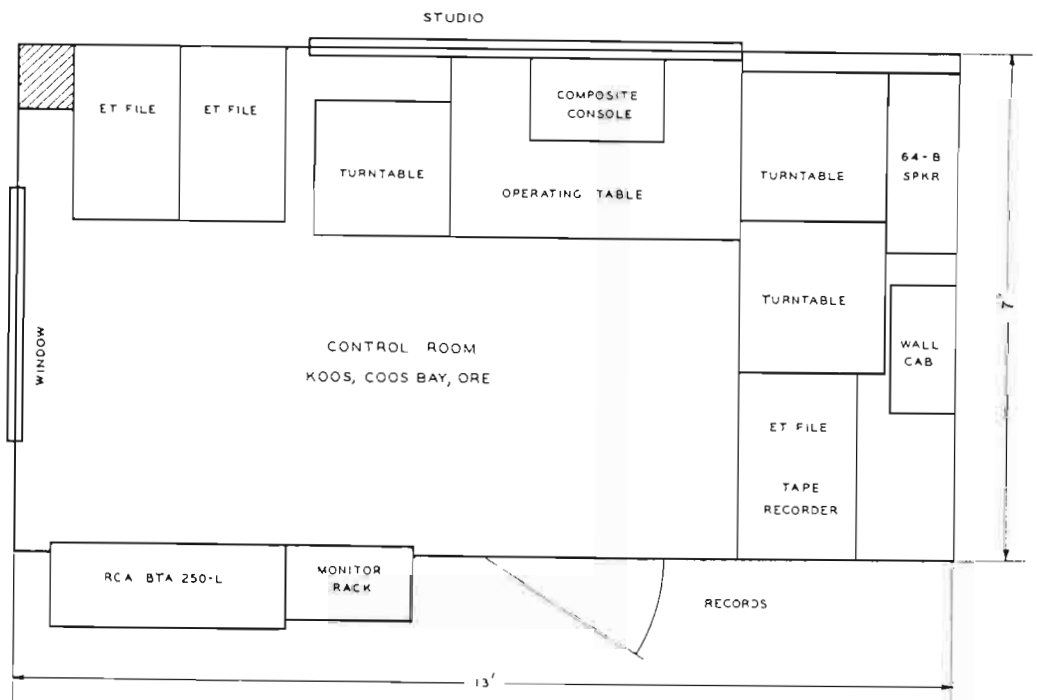

KSYC . . . 250 W

Yreka, California

by JACK R. WAGNER
Manager

KSYC, a 250-watt AM station, located in Yreka, California, presents another good example of efficient design for the smaller radio station. In order to hold down operating expenses, the station combines both studios, offices and transmitter in a single building. It is operated by the Siskiyou County Broadcasting Company.

When the KSYC building was designed, more emphasis was placed on providing ample control room and office space than in building a large studio. The building includes a roomy reception room which doubles as the general offices, and an adequately large control room, work room, and manager's office. (See Fig. 1).

When local shows require an audience or a large orchestra, the programs usually take place in the theatre or hotels and are fed remote to the studio. The addition of a large studio may come later by the simple construction of another wing on the left side of the building. In this way the outside window of the control room can open on the large studio. The reception room window can become a doorway into the new wing.

The 250-watt RCA transmitter is installed flush with the wall (Fig. 2). The rear of the transmitter opens on the work room. This type of construction provides easy accessibility to the unit for servicing.

FIG. 1. This floor plan shows the layout of the transmitter, offices, and studio of Station KSYC. Additional studio space can be provided by the addition of a wing on the left side of building.

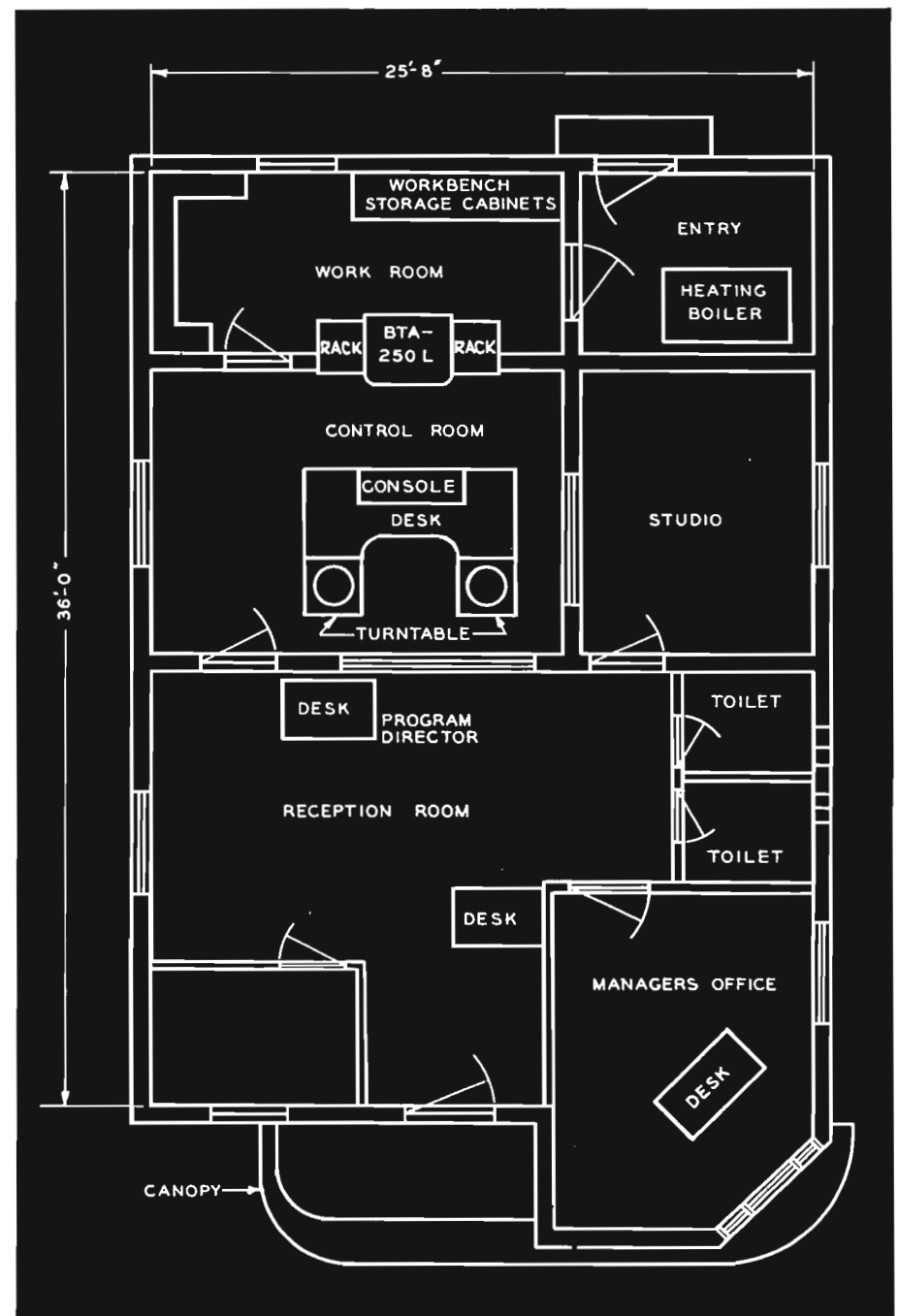

FIG. 3. Photo at lower right shows the single story studio-transmitter building of KSYC with antenna tower at left. The building is constructed of cinder blocks and employs radiant type heating.

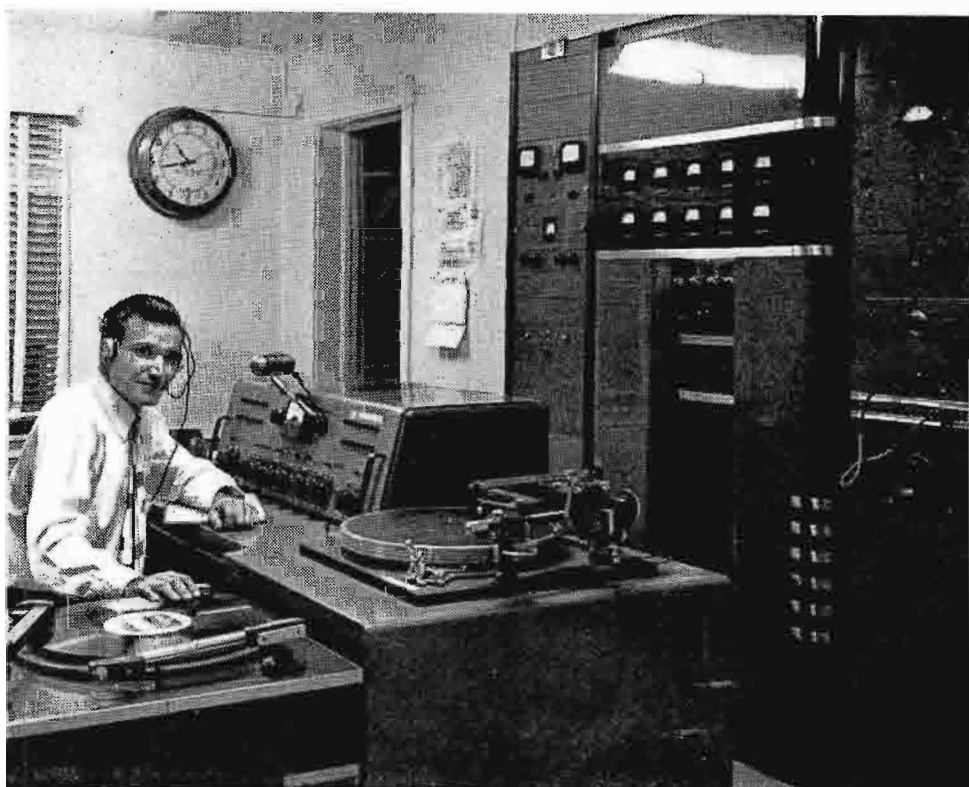

FIG. 2. The 250-watt RCA transmitter, mounted flush with the wall, provides a neat unified appearance. The transmitter is flanked by audio and test equipment racks.



by **PAT M. GOODOVER**
 President and General Manager

250 W . . . **KXLL**
 Missoula, Montana



FIG. 1. Shown above is the transmitter building of KXLL which is situated about 200 feet from a river. The antenna tower shown at rear of the building is located at river's edge with half its ground system buried under water.

KXLL, located in Missoula, Montana, is one of the most important outlets of a chain of eight affiliated radio stations known as the Pacific Northwest Broadcasters which serves over two and a half million people in Montana, Oregon, and Washington.

Because of its strategic location in the center of the Pacific Northwest chain, KXLL is frequently called upon to switch back and forth between the stations in Montana and its affiliated members in Washington, and Oregon. At times it originates its own shows and it feeds both east and west legs of the PNB circuit.

To accommodate the various functions required for network operation, KXLL has had to modify its basic RCA equipment. A three inch panel, which serves as a base for the RCA Consolette, houses the various controls and relays which permit special purpose switching between the legs of the network.

The transmitter building is situated on a plot of ground on the banks of the Clark Fork River. One half of the station's ground system is perpetually under water. The antenna tower is located on the edge of the river.

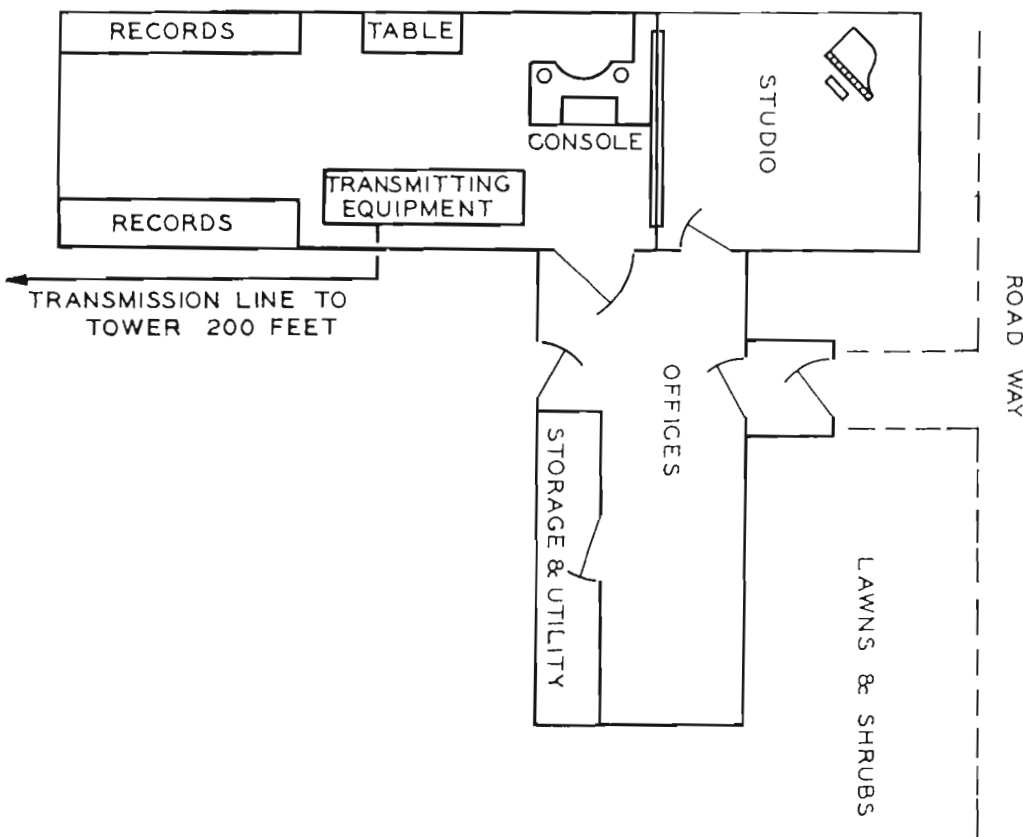

FIG. 2. Photo above shows a simple floor plan of Station KXLL. As can be seen in the plan, the operator at the control position has a good view of the studio and other office facilities.

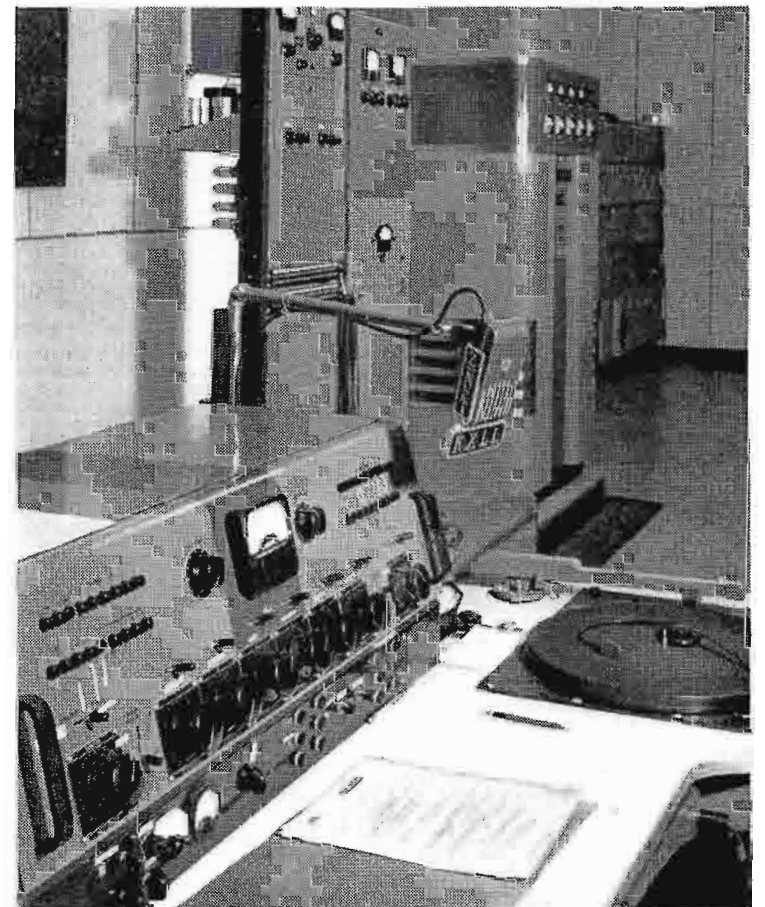

FIG. 3. The control console and transmitter are so placed that the operator can easily monitor all the equipment.

KRDO . . . 250 W AM

Colorado Springs, Colorado

by **JOSEPH ROHRER**
President and General Manager

The City of Colorado Springs is an ideal place for a 250-watt independent radio station such as KRDO. The population is between sixty and seventy thousand and the city maintains a brisk retail trade—in the neighborhood of seventy million reported during 1948.

Programming features music, news and sports. On the spot coverage of special events by direct lines has included such events as hockey broadcasts from points as far as California and Michigan. It has carried over thirty football broadcasts during the 1948 season.

Because the station engages in so many remote pickups, special remote lines have been permanently installed between the station and the Colorado College, the high school, the city auditorium, the Fine Arts

Center, and several other civic centers and churches. Twenty remote lines to the telephone test board are in use regularly.

In addition to employing the numerous telephone circuits, KRDO has three remote pickup transmitters which are used in broadcasting special events such as Pikes Peak Hill Climb on Labor Day, emergencies such as floods and forest fires, and civic activities such as parades, clean-up drives and dedications.

The KRDO mobile studio (Fig. 5) is the best equipped and finest unit of its type in the state. It carries enough equipment to make it possible to bring the radio audience a word picture of almost any event. The technical equipment, carried by the studio on wheels, consists of a 100-watt transmitter, remote mixing and

pre-amplifiers, a recorder, a public address system, an all-band receiver, and a parabolic microphone. The interior of the unit can accommodate a dozen people. A platform on top of the mobile studio makes a perfect place from which an announcer can describe special events. The mobile unit has already been used near the summit of Pikes Peak at an altitude of 14,000 feet, proving its mobility.

The station has a staff of fifteen, including a general manager, a business manager, two commercial salesmen, three announcers, two full-time and two part-time engineers, two of which act as announcer-engineers, program manager, copy writer, news editor, and receptionist-stenographer.



FIG. 1. Tower insulators of the KRDO antenna are located 25 feet above the ground level of a one-story garage.

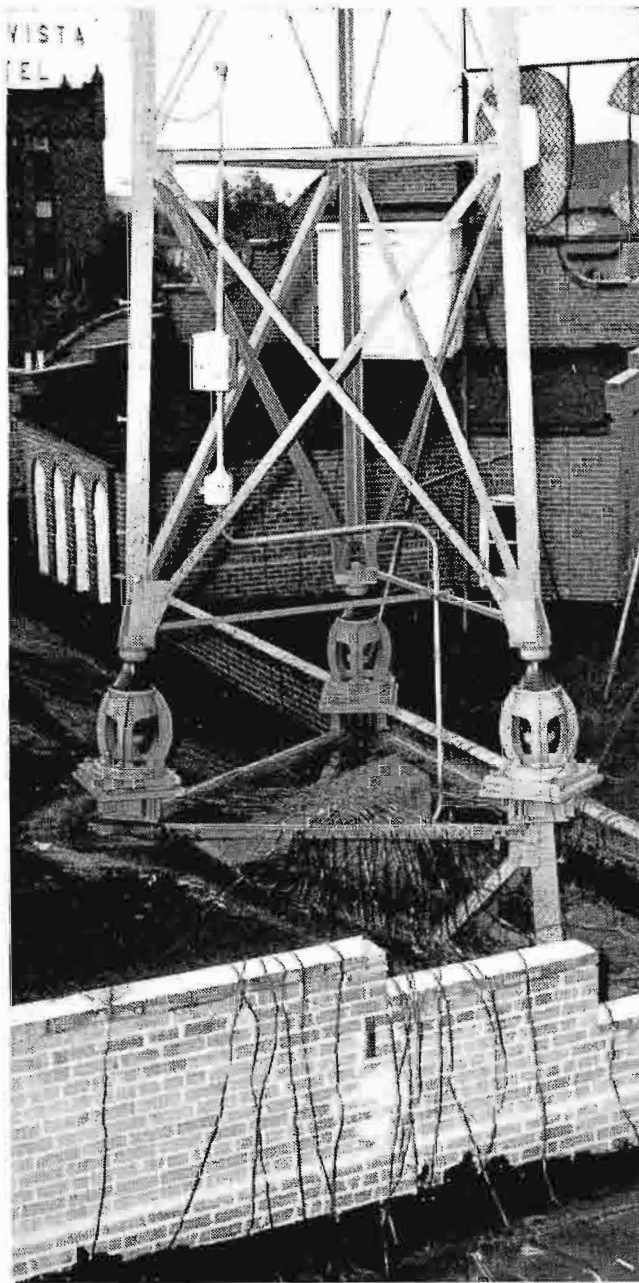

FIG. 2. The ground system includes 25,000 feet of copper ribbon laid out radially as shown. In addition, 5,200 square feet of copper ground is located at the tower base.

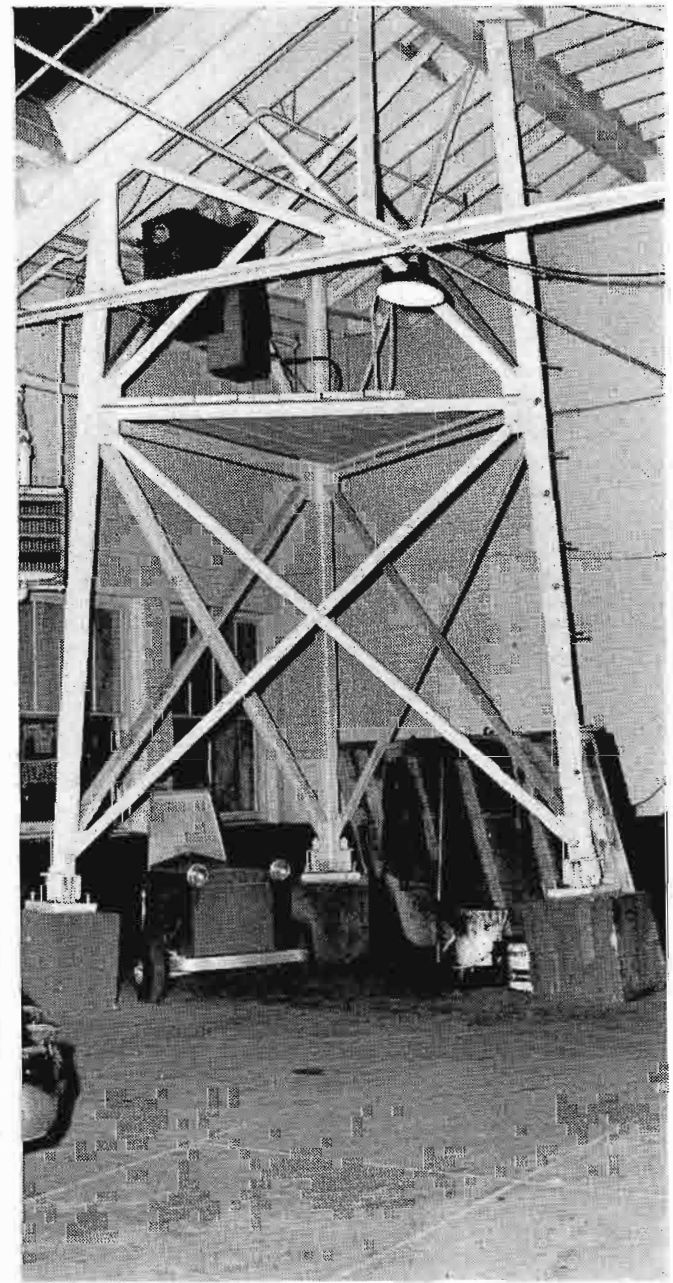

FIG. 3. The base of the KRDO tower is built inside a garage. The tower pylons were sunk eight feet in the ground. The tuning unit and lightning choke are shown at upper left of photo.

The studio equipment consists of a 76-B2 Console and three 70-C2 Transcription Turntables with BA-2A Pre-amplifiers. Line equalizers, volume indicators, bridging and matching coils, attenuators, and jack bays are installed in racks for operating convenience. There are three studios grouped around the control room, two of which are used for announcing only, and a third which measures 18 by 33 feet is used for live talent programs.

A 250-watt RCA transmitter, RCA Type BTA-250-L, operating at 1240 kc, provides excellent coverage for Colorado Springs. The monitoring equipment consists of a WF-48A frequency meter and a WM-43A modulation monitor.

Most unique feature of the KRDO installation is its tower construction and counterpoise. The tower is located five hundred feet from the transmitter in the hotel and is fed with 72 ohm concentric cable which is run overhead across the street and suspended from a carrier cable.

The ground system consists of 25,000 feet of three-quarter inch copper ribbon laid out radially every three degrees around the tower. In addition, there are 5200 square feet of copper ground screen at the tower base.

The steel beams supporting the roof are all bonded into the ground system. The base of the KRDO tower is inside the garage building. The tower pylons extend eight feet into the ground. The antenna tuning unit and lightning chokes, located just under the roof, are easily accessible from a large platform. (Fig. 3).

250 W AM . . . **KRDO**
Colorado Springs, Colorado

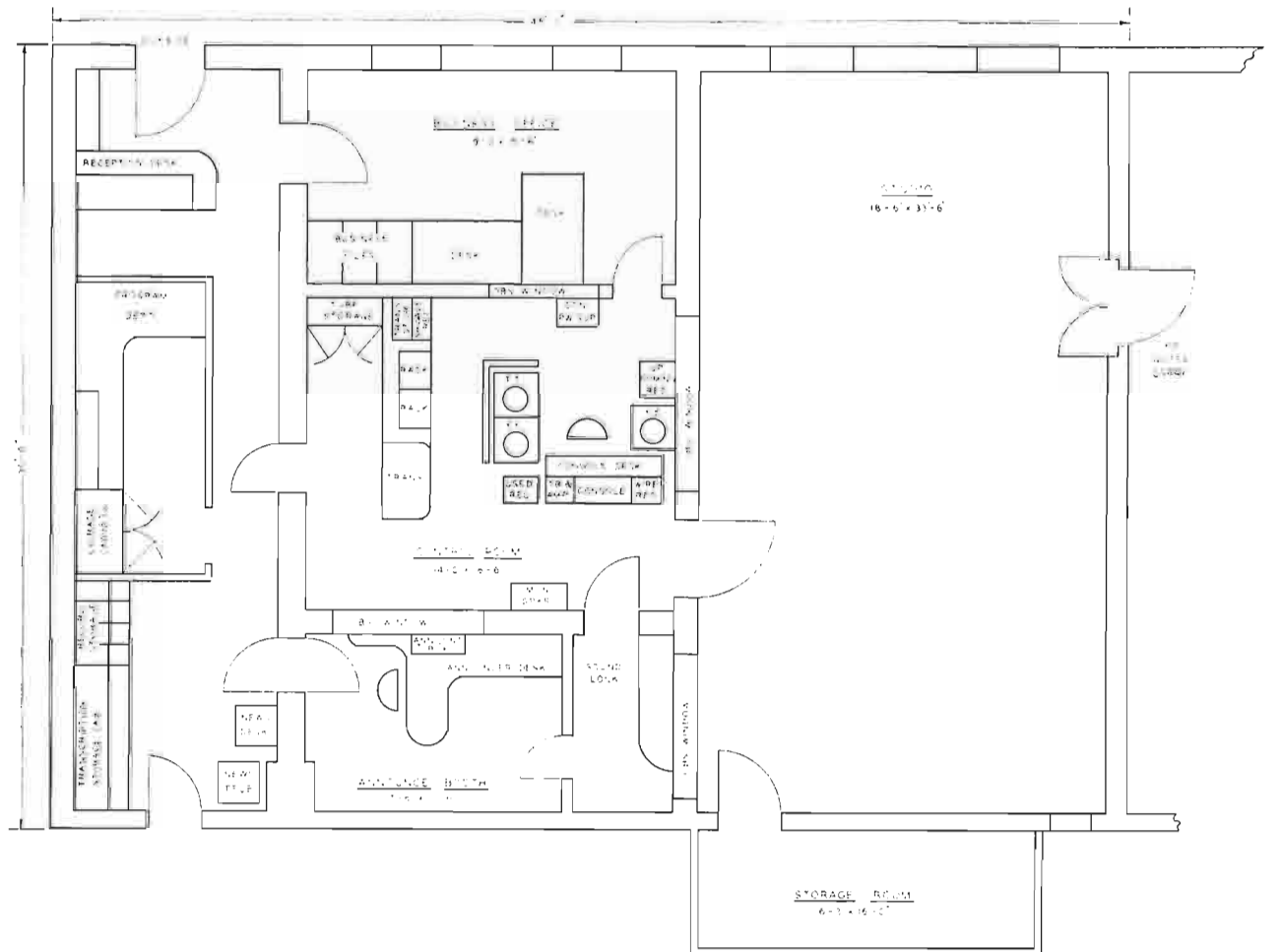

FIG. 4. The floor plan (above) shows the layout of station KRDO including the studios and transmitter located on the ground floor of the Alta Vista Hotel.



FIG. 5. The KRDO mobile unit is adequately equipped to broadcast almost any event. As shown, the roof serves as vantage point for the announcer. The small "dish" is a parabolic microphone.



FIG. 6. The main control room houses the transmitter and studio equipment which is one hundred percent RCA.

WHHM . . . 250 W

Memphis, Tenn.

by **WILLIAM MARSH**
Chief Engineer

The technical equipment at WHHM was chosen and installed with this general idea in mind: to operate well, consistently, with flexibility, and permit operation by relatively inexperienced personnel. In a large measure, these requirements were fulfilled by making the equipment essentially RCA throughout. Operating flexibility has been accomplished by careful equipment facility installation. The transmitter building itself was designed with the idea of keeping expenses as low as possible and including only necessities.

The studios of WHHM are located in a large office building in the downtown section of Memphis. The studio layout consists of lobby offices, an audition room, one large studio, one small studio, and two control rooms.

The studio equipment comprises two RCA 76B Consolettes, two cabinet racks with auxiliary equipment, and four turntables. The equipment is arranged and assembled so that one non-technical combination man can operate it. Consolettes are interlocked so that only one can be on the air at a given time. Studio cue speakers and microphones are interlocked so that it is almost impossible to do anything wrong with them. Each control room operates as nearly as possible like the other.

This lessens operating blunders and makes it lots simpler to train new personnel.

An over-all master intercommunication system, which is interlocked with both control room circuits, connects all offices and operating positions. A house monitoring system enables all offices and audition rooms to monitor all channels with no technical assistance. As the system is centralized, no amplifiers need turning on at any monitoring location.

Auxiliary order wires, phone sets, head phone extensions, telegraph extensions and the like are wired in where they are likely to be needed. Accordingly, very few emergencies or complications arise, in spite of the fact that the station operates with a heavy schedule 24-hours per day.

Servicing is usually accomplished by the very simple non-technical expedient of changing control rooms. This automatically switches all equipment facilities at one time, and leaves the other equipment free for servicing.

The station's transmitter building is located approximately two miles from the studio, and is connected with it by one program line, one auxiliary program line, which doubles as an order wire, and a regular telephone line.

The geographical location of the transmitter is very nearly in the center of the city's population. The transmitter building is located in a large field, zoned commercially, and adjacent to one of the principal railroad yards. All the track nearby probably assists the ground conductivity.

As may be seen in the floor plan, (Fig. 5), the architecture of the building is very simple. It is built on a concrete slab, with walls being constructed of concrete blocks. The cheapest style of construction was used on the roof. About the only unusual thing architecturally is the window construction (Fig. 4). All windows are placed from the ceiling down to about five feet from the floor. This construction facilitates placement of furniture and equipment, since practically all wall space is available with a maximum of light.

The heating system consists of one gas circulating heater. This has been quite satisfactory as the climate of Memphis is temperate. The only noticeable fault in the transmitter building construction is the lack of dead storage space. It is quite likely that in the near future the station will have to construct some smaller building to provide more storage facilities.

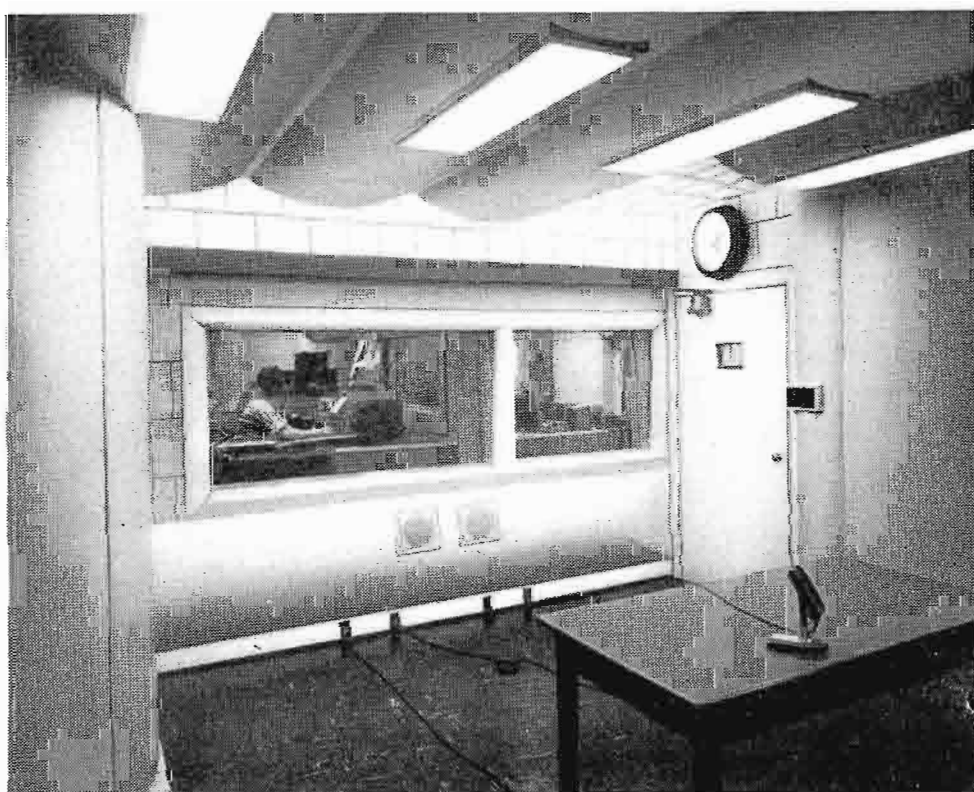

FIG. 1. Shown above is one of the WHHM studios which has been acoustically treated with polycylindrical diffusers. Note that programs can be monitored by either of two control rooms.



FIG. 2. This is control room #2. Window at right opens on another control room containing duplicate equipment. Both open on studio shown in Fig. 1.

In the transmitter building of WHHM, the frequency and modulation monitors are located beside the operator's desk. An aural monitor has a selector switch which enables the operator to check operation at a number of points between the program's arrival and its return off the air.

The RCA 250-watt transmitter is located in the center of the room, giving good access for the occasional service it gets. Power is brought into the house from two separate sources, lessening power failure trouble.

Electrically, there is only one unique feature in the transmitter plant construction. The station installed a relay controlled device for removing the thermocouple and meter from the circuit in the antenna tuning house. This circuit seems to have functioned satisfactorily, since there have been no failures due to lightning.

The transmission line consists of three pieces of RG 8U on top of a barbed wire fence leading from the transmitter building to the tuning house.

The antenna is a Wincharger, which is fed from the small dog-house which contains terminating equipment for the transmission line.

WHHM has operated on a 24 hours a day schedule since its start in 1946. This would appear to present both personnel and technical problems. Actually, the personnel problem is somewhat simplified by using a larger number of operators than would be expected, and paying them per hour worked. A total of seven operators are used for hours varying from seven to

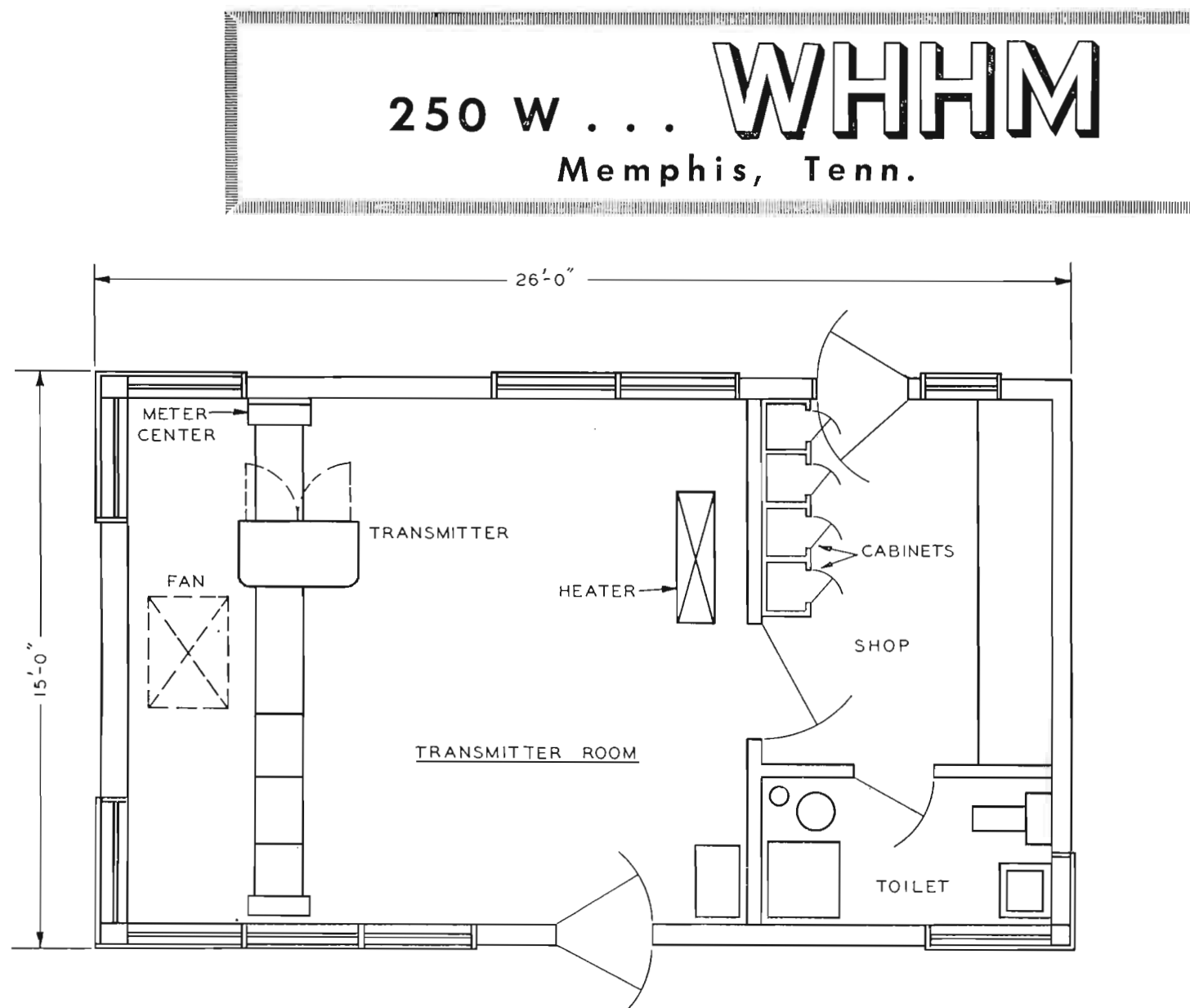

FIG. 5. This floor plan shows the equipment layout of the WHHM transmitter building. Note exhaust fan is mounted in the ceiling near the transmitter. WHHM finds this layout adequate except that it lacks sufficient storage space.

forty-seven per week. Most of the operators are parttime men who attend college in the city.

Since WHHM has only one transmitter, and inasmuch as WHHM has operated 24 hours per day since its start, maintenance

has presented an insolvable problem. The partial solution is to give as little maintenance as possible and that only during emergency conditions. So far, thanks to tough equipment, and good luck, we are still running 24 hours per day with almost no maintenance.

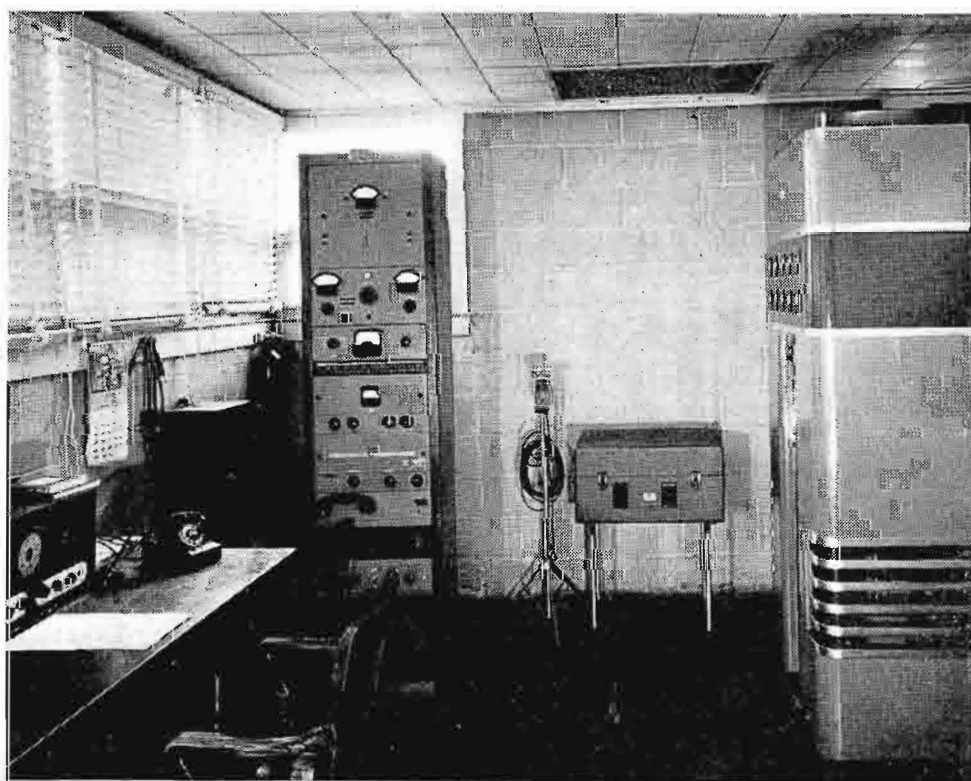

FIG. 3. This photograph of the interior of the WHHM transmitter building shows the operator's desk, the audio and monitor rack, a utility turntable, and the 250-watt RCA transmitter.

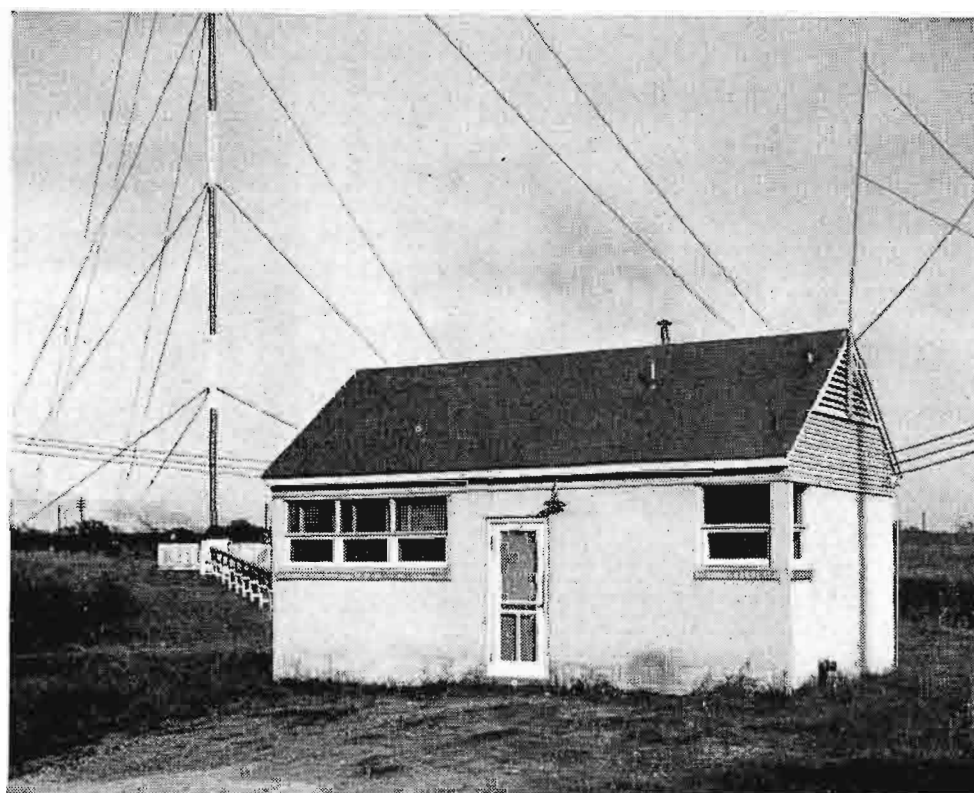

FIG. 4. The WHHM transmitter building is constructed of concrete blocks. The windows were built near the ceiling, permitting a maximum amount of wall space and light.

WSRS . . . 250W AM/FM

Cleveland Heights, Ohio

by
BEN H. WHITTAKER
Chief Engineer

Cleveland's "family station" (WSRS), which first went on the air on December 7, 1947, is now providing coverage with both AM and FM services. The station maintains and operates an RCA 250 Watt AM transmitter (type BTA-250L) at 1490 KC—and an RCA 250 Watt FM transmitter (type BTF-250A) at 95.3 megacycles. Station performance has proved to be very satisfactory for both AM and FM.

Transmitters

The 250 Watt AM and FM transmitters (as well as studio and associated equipment) are housed in a brick-constructed building located in Cleveland Heights, Ohio. The AM and FM transmitters are flush mounted "in-line" with two monitoring, test and audio equipment racks (see Fig. 1 and floor plan of Fig. 5). Transmitter room doors provide access to the master control room. The centralized transmitter room arrangement enables flexible transmitter control from one location.

Antennas

AM power is radiated from the Truscon tower (see Figs. 2, 3 and 4) which was erected on top of the two-story WSRS building. The tower erection and Pylon

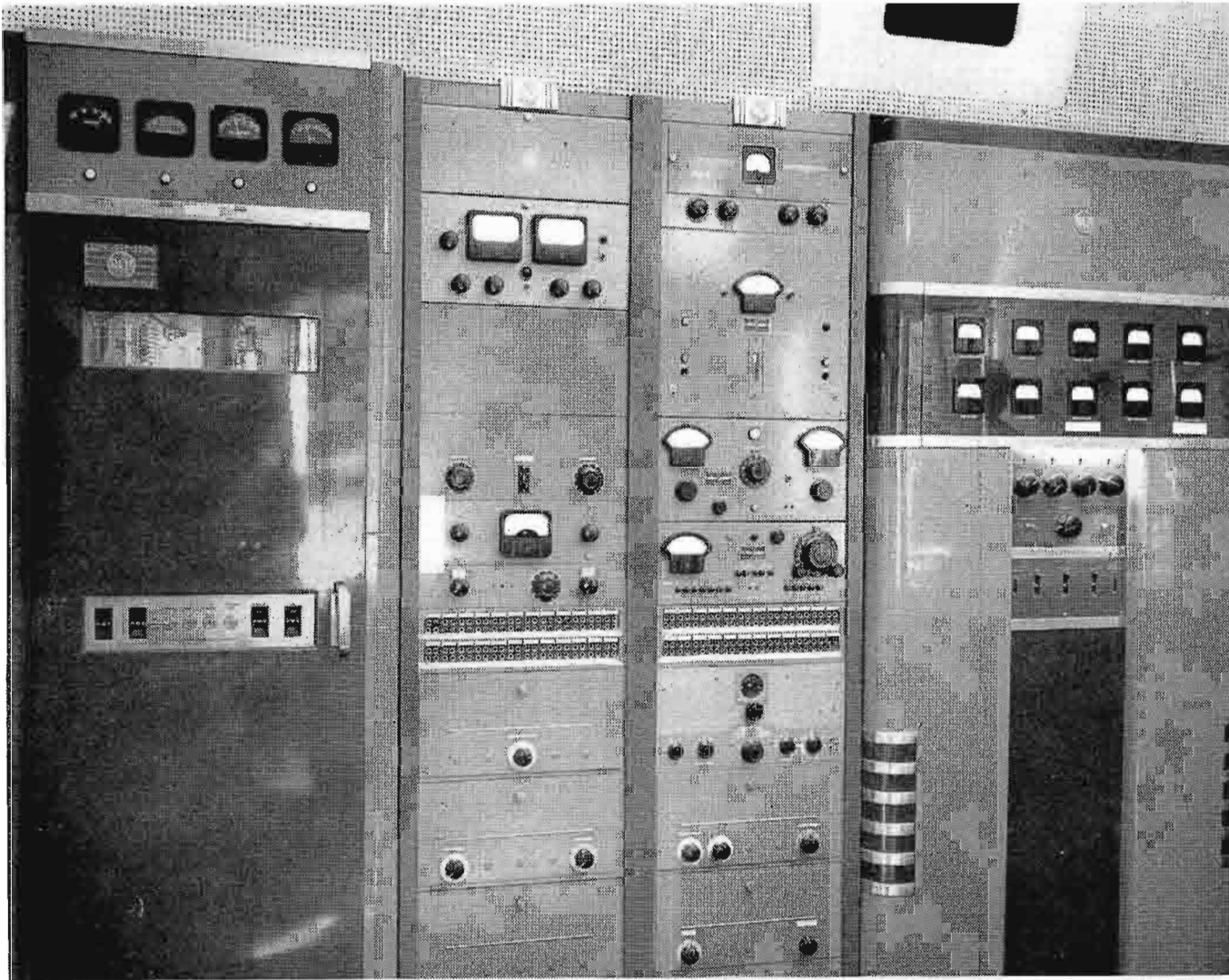

FIG. 1. (above). 250-watt RCA FM transmitter at left, two monitoring, test and audio racks center, and 250-watt RCA AM transmitter right are flush-mounted "in-line," as shown here.

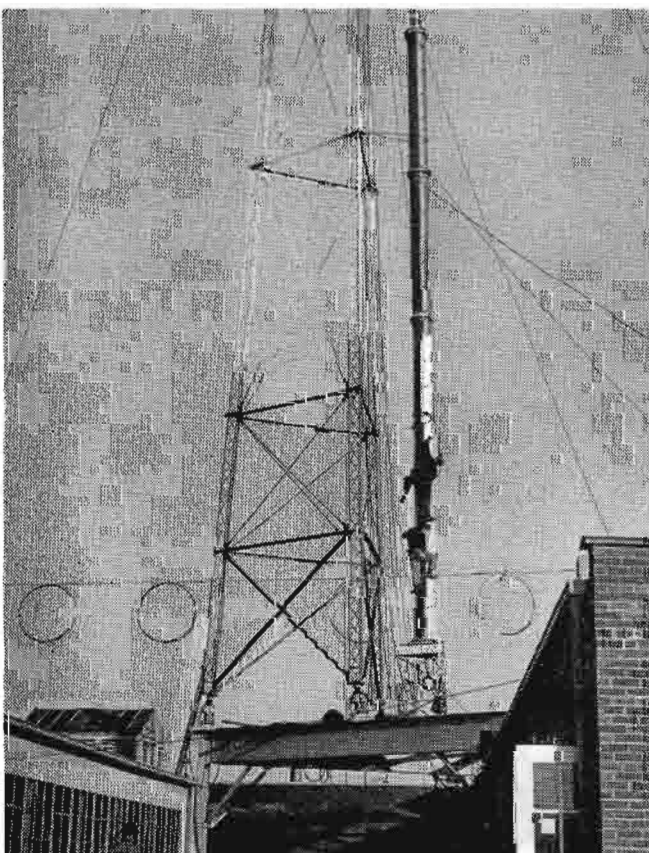

FIG. 2. Four-section Pylon completely assembled is shown here ready to be hoisted up the tower.

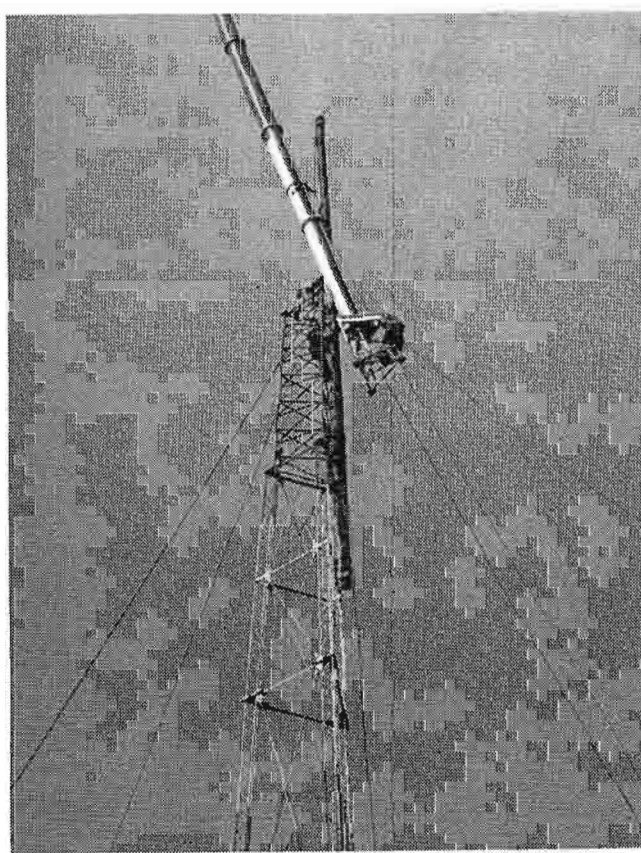

FIG. 3. The RCA, FM Pylon just before placement atop the WSRS tower.

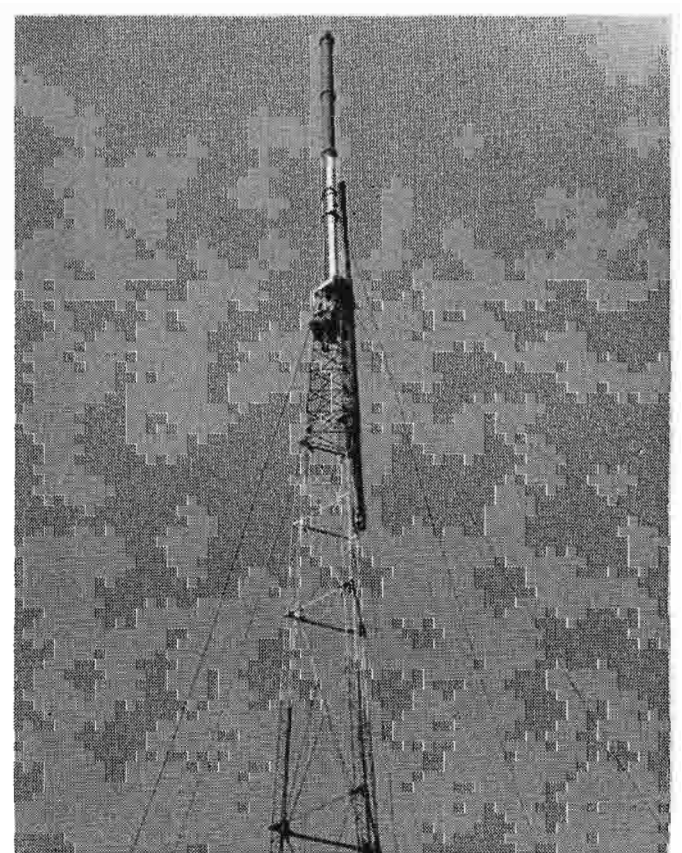

FIG. 4. View showing the 4-section Pylon as it appears installed atop the supporting tower.

installation was completed by Vogt and Conant Contractors, Cleveland, Ohio. An RCA AM/FM isolation unit was used at the tower base, thus making it possible to accomplish both AM and FM operation from one tower. The RCA Type BAF-14A FM-AM Isolation Unit transfers FM power across the insulating zone of the AM antenna tower to feed the FM Pylon antenna mounted atop the tower. It is designed to provide complete isolation of FM and AM signals and provide efficient operation over the entire FM frequency range.

The FM antenna used was an RCA four-section Pylon which was hoisted and installed as a single unit. This procedure proved to be easiest to handle, since the entire installation is situated on top of the building. The Pylon was assembled entirely in a horizontal position on the roof, then mounted on the top six-foot section of the tower. Although this added to the weight to be hoisted, it gave us protection for the transmission line protruding from the bottom of the Pylon. It may be interesting to note that since this was a roof-top installation, the erection crew could not bring power winches close enough to use. Consequently, the entire Tower and Pylon were erected by hand winches. (The Pylon and six-foot section of tower weigh approximately 3,000 lbs.)

Photos show in the foreground the messenger cable and coils of copper wire which make up the counter-poise system. At the completion of the tower erection, the copper wire was fastened to the AM tower base at every 3 degree radial.

Studios

WSRS (as shown in floor plan of Fig. 5) employs a studio setup which, in effect,

FIG. 6 (at right). Control room for studio "A" showing RCA 76-B4 consolette and 70-D transcription turntables (equipped with recording attachments).



FIG. 7. Samuel R. Sague, President and General Manager of WSRS broadcast facilities and operation.

250W AM/FM . . . WSRS

Cleveland Heights, Ohio

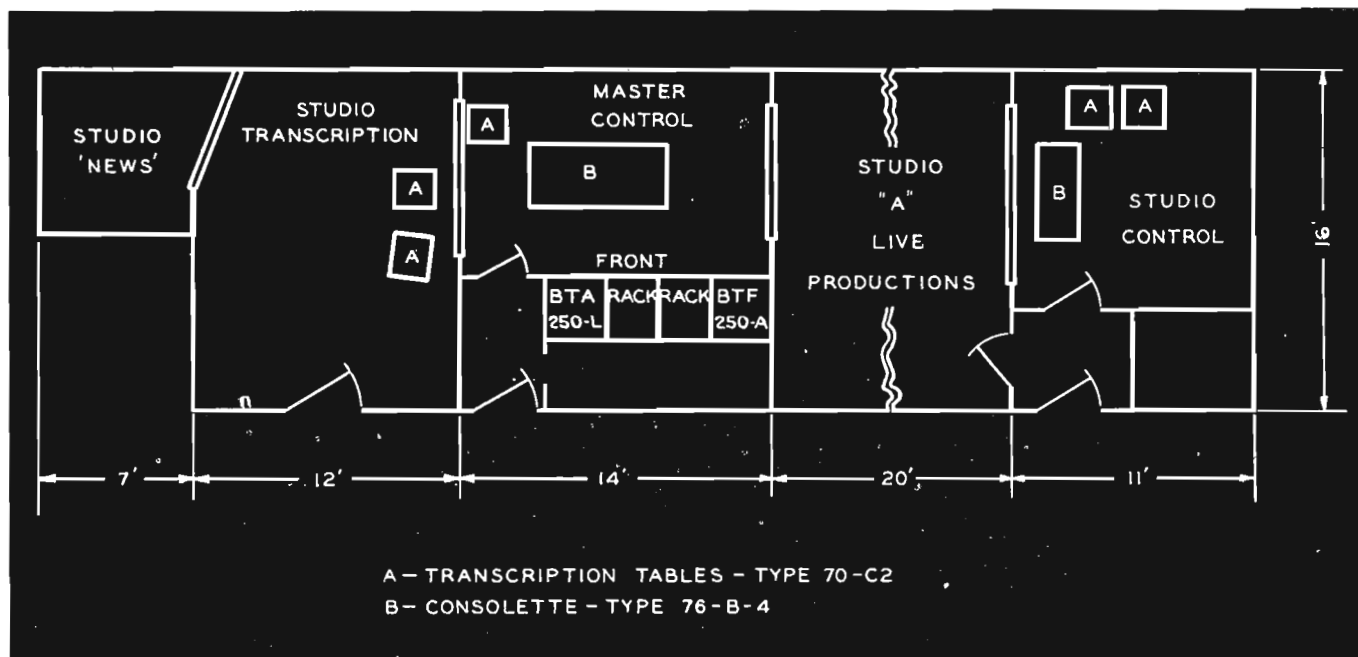

FIG. 5 (above). The WSRS single-floor station plan showing transmitter room and studio layout.

provides three studios for regular operation, plus a large automobile showroom situated on the ground floor of the building.

The studios are adequately handled by the two control rooms; master control and control for WSRS studio "A" (15 x 27 feet). Two RCA recording attachment units are mounted on type 70-D turntables located in the studio "A" control room (see Fig. 6). Large shows and plays are accommodated by studio "A" arrangement.

An RCA Type 76 Consolette is used in master control and another in "A" studio control. Normal disc shows and news announcements are handled directly from the master control position. Master control consists of the operator's desk, consolette, turntable, an RCA Type BCS-2A switching console and a remote panel box. With some minor modifications and rewiring of consolettes, WSRS has arrived at a rather "semi-custombuilt" installation which is extremely flexible and easy to operate.



WISL . . . 1 KW AM

Shamokin, Pa.

WISL DIRECTIONAL PROBLEM SOLVED WITH FOUR-TOWER ANTENNA ARRAY

By **B. T. MARSHALL**
Chief Engineer

Radio Station WISL (Radio Anthracite, Inc.) which is located in Shamokin, Pa., has been serving the anthracite region of central Pennsylvania for over a year. The new 1 KW AM broadcast station was conceived in the minds of a small group of public spirited citizens with a desire to provide complete local radio service to Shamokin community which lacked primary radio service at night prior to the advent of WISL.

Antenna Array Location

Engineering studies and surveys started in 1946 resulted in the filing of an application for 1000 watts on 1480 KC, with night-time protection provided (by a four tower antenna array) for existing stations on this channel. The antenna array (see Fig. 1) had to be located southeast of Shamokin in order to serve the purpose of its design. This particular area, at first, yielded no prospect for a suitable site because of the rising brush covered slopes of Big Mountain and the man-made ravines resulting from previous coal stripping operations.

An aerial survey finally revealed a flat section, on the slope, large enough to accommodate the array. After a C.P. was granted, work began in June of 1947.

Building construction and equipment installation proceeded smoothly. However, some delay was encountered while laying radials since huge rocks just below the ground surfaces mangled the laying plow. A highway roter was finally equipped with a feed pipe. This massive piece of equipment pulled by a heavy duty "cat" planted 720 radials in four days.

Equipment tests, shaping of contours, and proof-of-performance were started in the late fall of 1947. Due to the rugged ter-

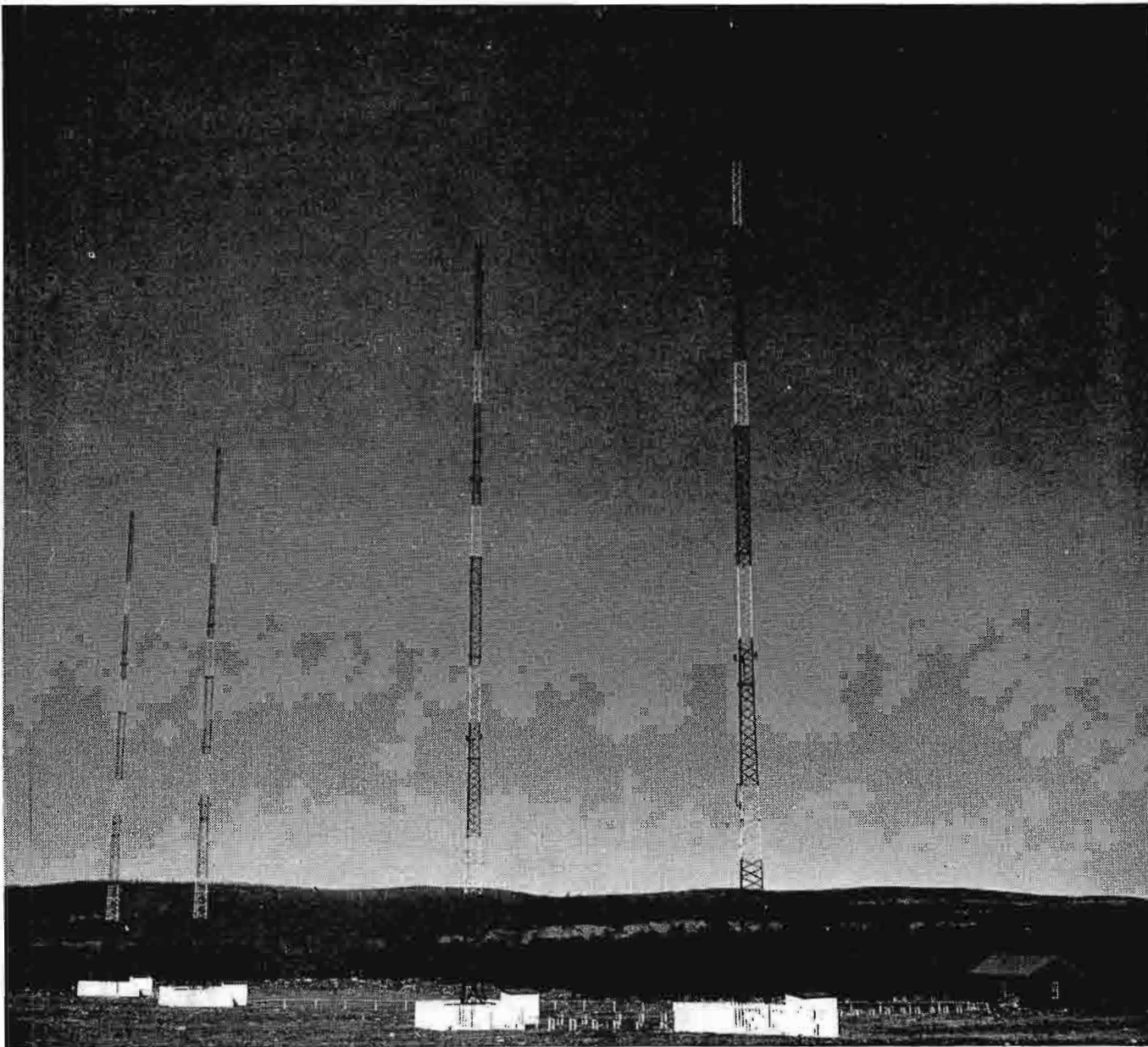

FIG. 1 (above). View of WISL's four-tower directional antenna array with lines to towers visible.



FIG. 2 (at left). Chief Engineer, B. T. Marshall (left) and General Manager, C. R. Petrie inspect an RCA test and audio rack during installation.

rain and danger of driving into stripping holes at night—the FCC granted permission to take field measurements in the daytime. Two-way radio was used to maintain contact between field cars and the transmitter.

Station Equipment

The transmitter house and studios were completely equipped with the latest RCA equipment, including the 1 KW AM transmitter (BTA-1L), 76 series consolettes, 70-D transcription turntable, two complete audio, test and monitoring rack equipments and necessary RCA studio and control room microphones.

Transmitter

The 1 KW transmitter and associated rack equipment were located as shown in Fig. 3. Transmitter design includes the RCA 250 watt transmitter (BTA-250L) which is used as the exciter for the 833-A Power Amplifiers which operate in a class "C" push-pull circuit. Plate modulation of the final amplifier is accomplished by two RCA-833A tubes, operating in class "B." The complete transmitter occupies an approximate floor area of only 14.5 square feet. The studio consolette and turntables were arranged in front of the studio window as pictured in Fig. 3, to provide a convenient arrangement for the operator.

With both studio and transmitter ready for final equipment tests, WISL was granted permission for program tests in January 1948. All tests proceeded satisfactorily and since operation started, no air time has been lost due to equipment failure.

FIG. 3 (right above). WISL transmitter room view showing RCA test, monitoring and audio racks at left and 1 KW transmitter (BTA-1L) at right.

FIG. 4 (right). View into WISL studio from control room in which 76-B5 consolette and 70-D turntables are located.

1 KW AM . . . WISL

Shamokin, Pa.

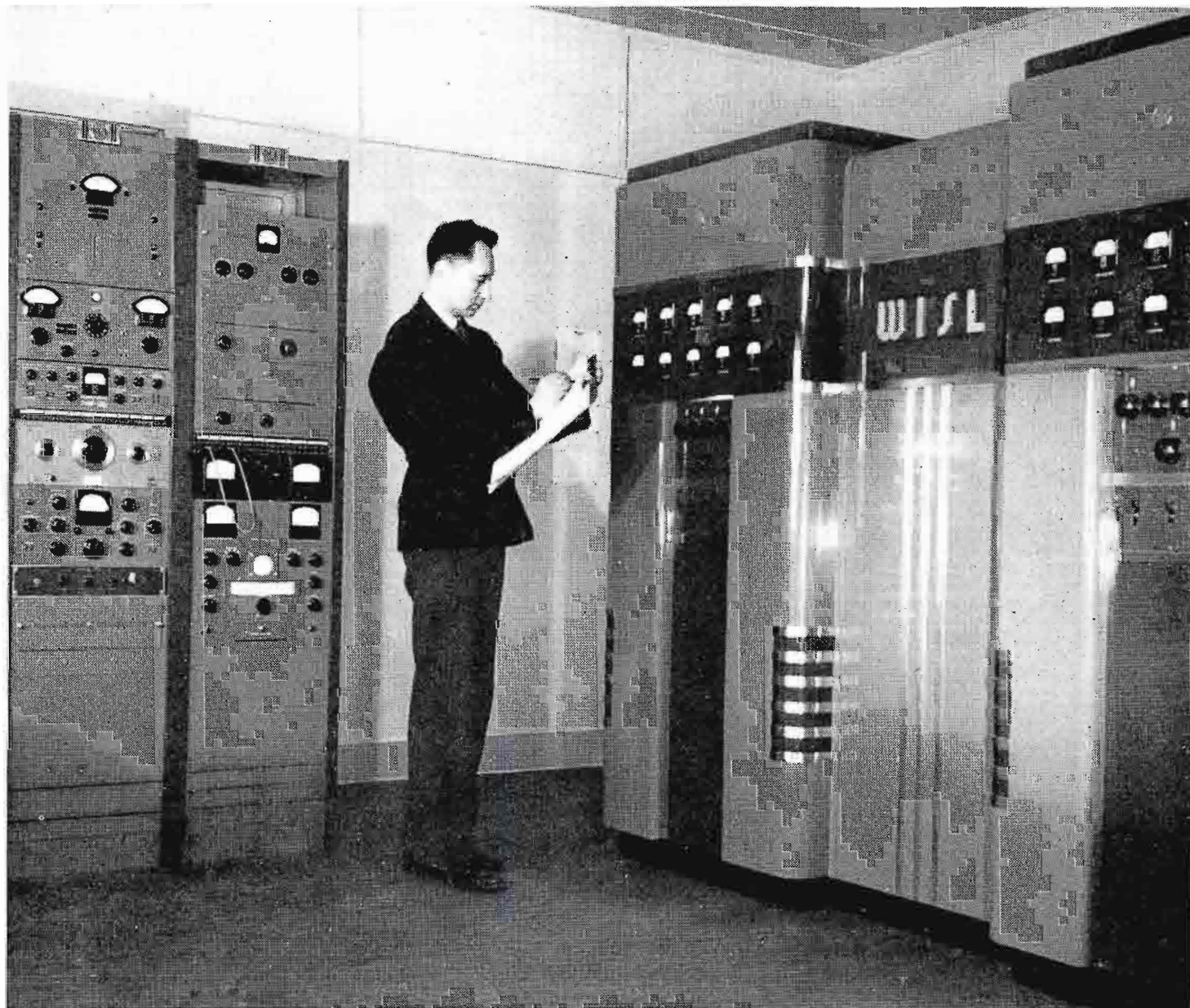

WLAKE . . . 1 KW AM

Lakeland, Florida

by **WILLIAM P. LEE**
Chief Engineer

When WLAKE started broadcasting with a power of 100 watts in 1936, the transmitting equipment used was composite. About two years later the power was upped to 250 watts. The station (as was true of many stations then) experienced difficulties during the first years of operation.

The present owner, S. O. Ward, purchased the station in 1942, and immediately began making plans for enlarging its operation and services to Polk County, Florida's fifth market. Even though the war was on, plans were drawn by Donovan Dean, local architect, for enlarged studio and offices. An application was prepared for 1000 watts full time operation, and just as soon as the FCC was ready to accept applications after the close of the war, the application was filed, and equipment ordered, every piece RCA. After a hearing and the usual waiting period, the grant came through for 1000 watts full time, non-directional, on 1430 KC. William P. Lee, chief engineer for the station, drew all plans and installed the new equipment. His ultimate goal set forth by management was—"Put in the best, most versatile announcer-engineer operation you can build, and make it all new—and modern."

Transmitter

The 1 KW RCA transmitter (BTA-1L) is located in a separate transmitter room of the building (see Fig. 1). The transmitter is situated so that it may be seen at all times by the announcer-engineer from his position in the studio control room. The entire 1 KW transmitter occupies an approximate space of only 9 feet by 20 inches. The station has installed a 10 KVA auxiliary power supply that works automatically. The tower is 199 feet high and is fed by an RCA line, and RCA tuning equipment. In order to centralize station control and operation, transmitter monitoring equipment is installed in racks located in the control room (see Fig. 1).

Studio Equipment

Fig. 1 (also see Figs. 2, 3 and 4) shows the announcer-engineer position which

FIG. 2 (at left). This view shows "announcer-engineer" position in the central WLAKE control room where RCA type 76 console and 70-D turntable are conveniently arranged.



FIG. 1 (above). The WLAKE, 1 KW transmitter is visible from window of central control room. Note that monitoring test and audio racks, as well as studio control consoles are all easily reached.



1 KW AM . . . **WLAK**
Lakeland, Florida

faces the studio control room window. From this position, the operator has access to both consolettes, both turntables—and as previously mentioned has full view into the transmitter room. Note in Fig. 2, how a special turret was installed between the consolettes. This serves to accommodate essential remote meters, tower indicating lights and city or auxiliary power indicators.

Studio equipment includes the two RCA 76 series consolettes together with a semi-custom built left-hand wing turret (see Fig. 2). The overall arrangement of studio equipment provides extreme flexibility of control and enables the switching of equipment into any desired combination. The large console desk is covered with dark maroon linoleum and trimmed in chrome. The lower portion of the console desk is used to house RCA amplifiers that are mounted on hinges for greater accessibility.

At the rear of the studio control room and behind the announcer-engineer's position, is located the RCA custom-built, dual-recorder console (see Figs. 3 and 4). It is also trimmed in dark red linoleum and chrome to match companion equipment. This arrangement includes two RCA 73-B professional recorders with switching facilities which permit simultaneous or individual recorder operation as desired. Continuous recording without breaks, program monitoring and cueing are possible.

Also visible in Fig. 4 are the three RCA equipment racks which are flush-mounted in one wall of the control room. Frequency and modulation monitors, test equipment, etc., are mounted in these racks which are adjacent to the transmitter room. (All relays are located in the transmitter room.)

The studio equipment in addition to that described above includes an LC-1A duo-cone monitoring loudspeaker, RCA microphones, wall-type monitoring speakers, etc. The general installation and arrangement of equipment at WLAK resulted in a convenient and centralized arrangement in which all essential controls are easily reached.

FIG. 4 (at right). Closeup of corner of WLAK control room showing three RCA equipment racks of monitoring, test and audio equipment at left—and dual recorder at right.

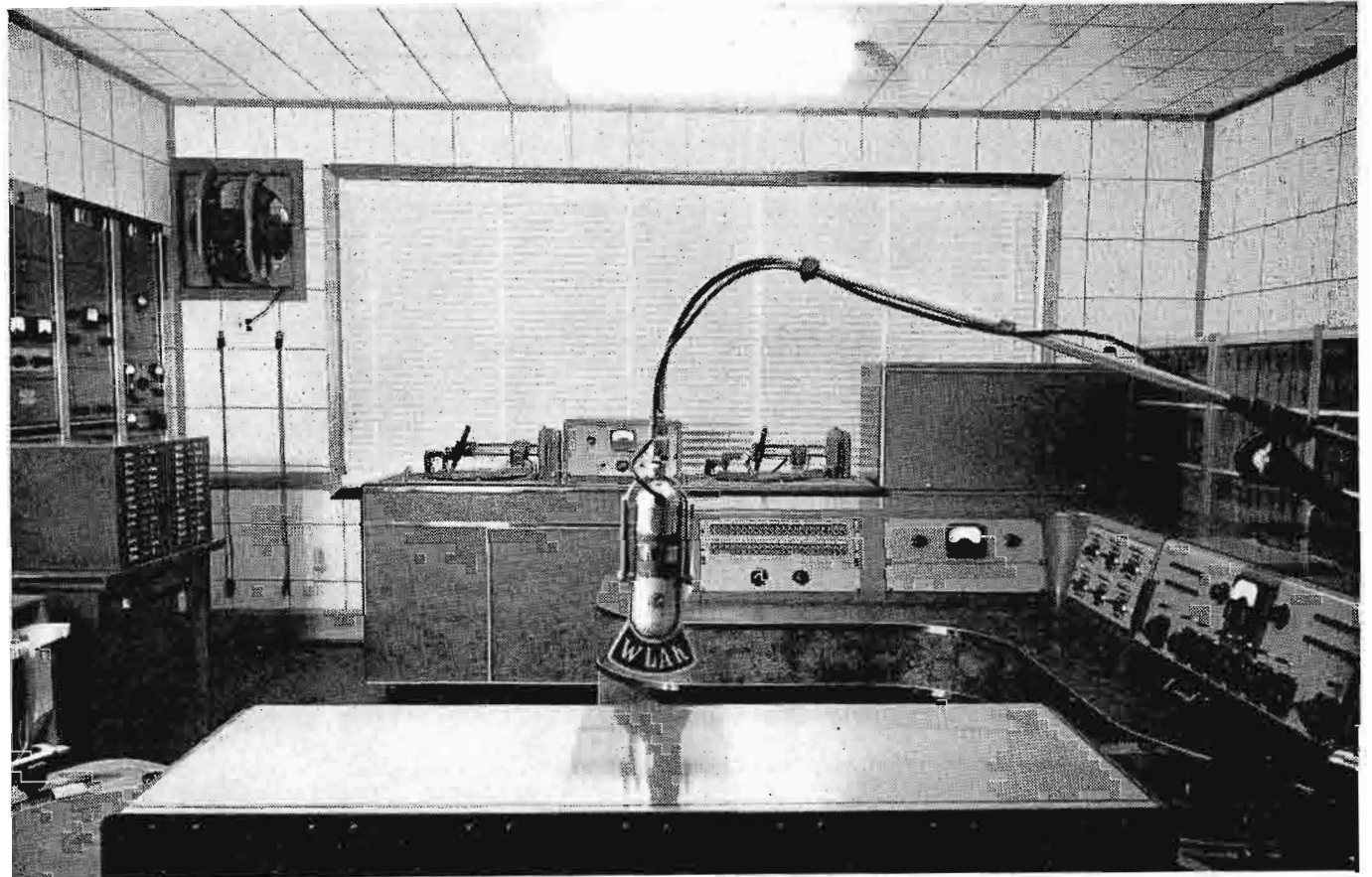

FIG. 3 (above). View from WLAK studio, looking into control room. Visible at rear is the WLAK dual-recorder which employs type 73-B professional unit.



WBCK . . . 1 KW AM

Battle Creek, Mich.

By **A. J. GERANIS**
Chief Engineer

The WBCK 1-KW AM transmitter is located on high ground two miles south of the center of Battle Creek. Since the ground conductivity in this section of the country is rather poor, no attempt was made to select a swamp site, but rather a site was selected that would afford good AM coverage with a view to its future use for FM or TV. (The site overlooks downtown Battle Creek, which makes it ideal for future operations.) Results since opening of the station seven months ago prove that the location is most satisfactory

for AM. Twenty-two acres give ample room for the directional antenna system.

Transmitter Building

The transmitter building was designed by the chief engineer and built by local labor. As can be seen from Fig. 2, the building contains enough room for the addition of a second transmitter to the left of, and at right angles to the present BTA-1L AM transmitter. In this event the speech racks would be moved from their present position to a new position at the left of the entry. A basement was built to provide room for the possible addition of large transformers, blowers, etc., and also to take care of future studio addi-

tions which could make the building a self-contained radio center. In that case the heating plant for the entire building could be placed in the existing basement. The heating plant consists of an oil type floor furnace, which provides ample heat for the present building. The two-car garage provides car space for the engineer on duty and also accommodates maintenance work too heavy or dirty to be handled in the shop. The use of cinder block construction covered with 'Brick-Kote' veneer gives a pleasing appearance at a reasonable cost.

Modification of BTA-1L

To get a more pleasing appearance of the combined transmitter and phasing installation, the phasing equipment was designed to match the BTA-1L cabinet and was placed *between* the exciter and the final amplifier power supply panel. How well it worked out, can be seen from the photographs (see Fig. 1). From left

FIG. 1. (below). WBCK's 1 KW transmitter room view showing how phasing equipment is located between the 250-watt exciter and 1 KW amplifier cabinets. Chief Engineer, A. J. Geranis is at transmitter control desk. At far left are test and audio input racks.



to right the units are: RCA exciter; phasing change-over controls and daytime phasing back of recessed panel; night phasing and line current meters; final power supply transformers back of recessed panels; RCA final amplifier. Placement of the phasing unit in the center and spreading the exciter away from the final has caused no technical or operational trouble whatsoever. The above design was the writer's idea and so far as can be ascertained, is the first time a BTA-1L has ever been given this same treatment. The reason for placing the phasing in the center (rather than in a right-wing cabinet of matching size) was due to the fact that a cabinet the same size as the final would not be large enough for the circuits required. Therefore an oversize cabinet in the center resulted in better physical balance and overall appearance.

An extremely short time (8 days) was required for tune-up and proof-of-performance measurements, indicating that the system of construction followed was evidently a good one.

Antenna System

The directional antenna system consists of three 250-foot Blaw-Knox type LT towers spaced 264.5 feet apart, on a line 342 degrees true. Coupling units are contained in houses made of waterproofed cinder block near the base of each tower. A series type ground system is used with 300-foot radials spaced 2 degrees. There is a 50-foot square Truscon ground screen at the base of each tower. The main innovation is in the use of solid dielectric coaxial cables as explained below.

COAXIAL CABLE INSTALLATION

Sampling Lines

Sampling lines are RG-8/U run in duplicate underground. All sampling lines were cut the same length, slightly longer than the longest run required. An r-f bridge was then used to show when they were trimmed to the same electrical length. All lines were terminated with Amphenol 83-1R receptacles for convenience in connecting the jumpers between the line used and the point of connection. Amphenol 83-1R receptacles were used on the Johnson sampling loops in place of the coaxial end seal supplied. The sampling loops were mounted on the towers at the 25-foot level and insulated from same. The sampling line was run up the towers in 1/2 inch conduit insulated from the tower by use of Premax #3S-20 heavy duty stand-off insulators. The section of conduit from tower to tuning house was made of

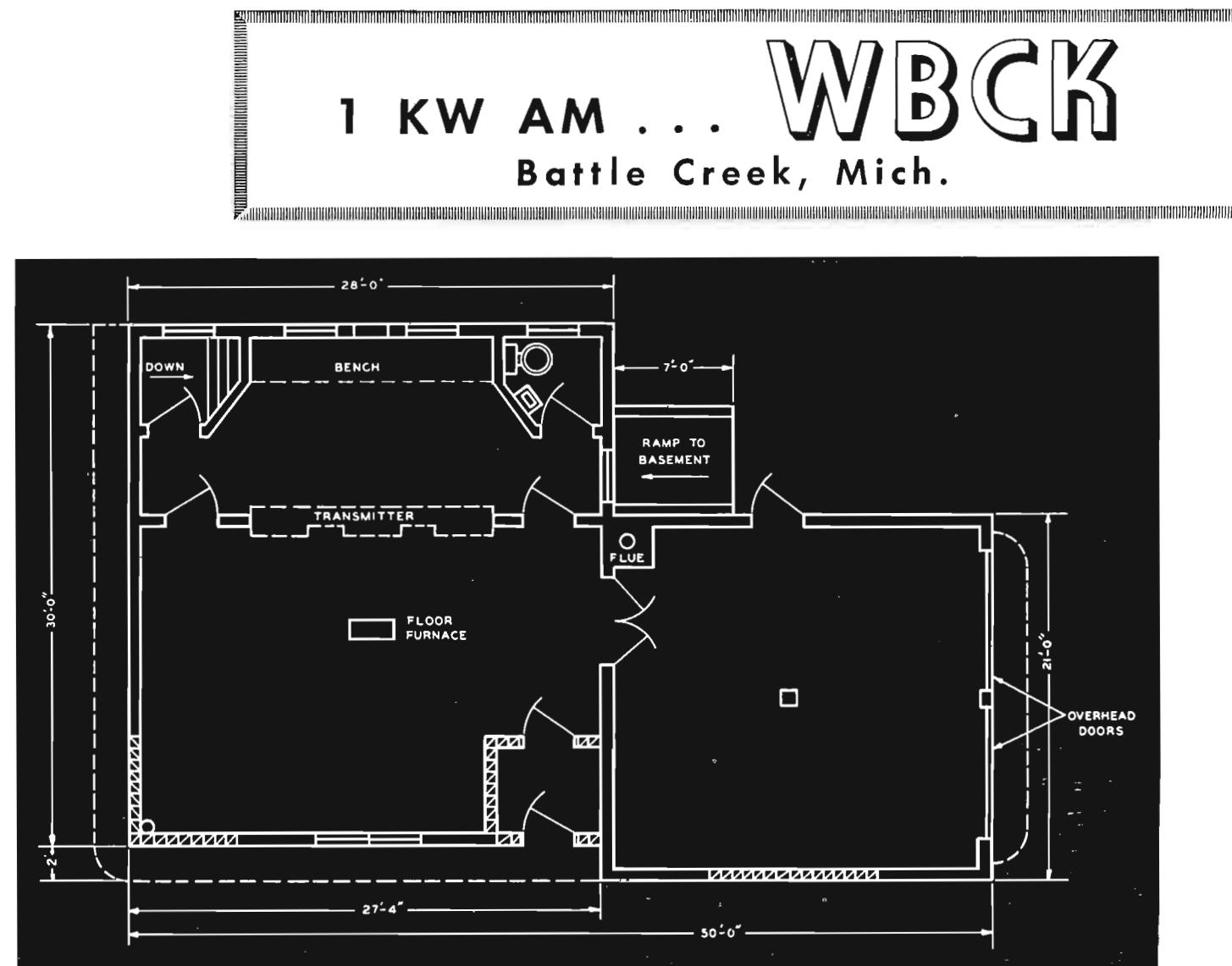

FIG. 2 (above). The floor plan illustrates how the BTA-1L is flush-mounted in one wall, with access doors provided at each side of transmitter.

copper, bent to provide a drip loop and to allow for movement of the tower in bad weather, etc. This method provides a rugged and inexpensive way of bringing the sampling line across the base insulator, and has proved trouble free in operation. All excess sampling line from the two near towers was coiled on a large drum fastened to the transmitter house basement wall near the tower conduits. (4 inch conduits from transmitters to towers.)

R.F. Transmission Lines

R.F. transmission lines were made of Amphenol 21-125 coaxial cable also run in duplicate underground. They were cut to the exact length needed for each run and terminated at the phase unit and also at the tower coupling unit with Amphenol #152-101 end seals. Choice of either line for separate towers is made by changing a short copper strap jumper at each end. Silicone compound was used in making up all connections.

Method of Installation

The entire cable bundle to each tower was run in 4-inch fibre (Orangeburg) conduit buried below the frost line. Each conduit run was broken approximately every 125 feet by a manhole constructed of concrete block with a poured concrete top. A cast concrete tapered block was used to

close the access opening. Since the soil in this area is sandy, no floor was used in the manholes so that drainage was obtained. The conduits are laid so as to be higher

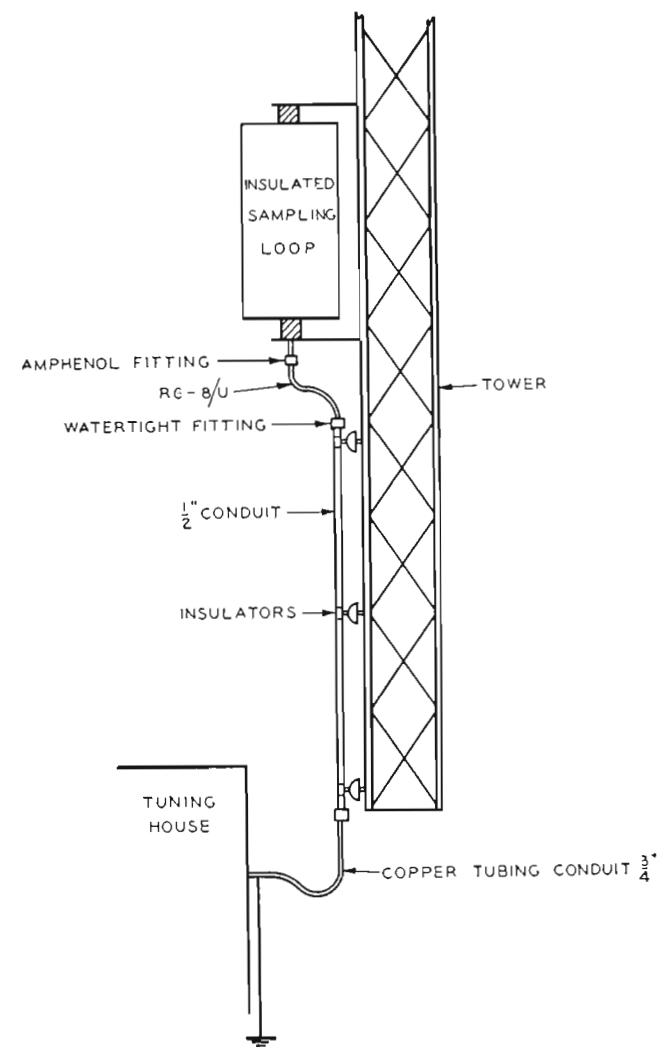

FIG. 3 (above). A line drawing which illustrates sampling loop detail.

WBCK . . . 1 KW AM

Battle Creek, Mich.

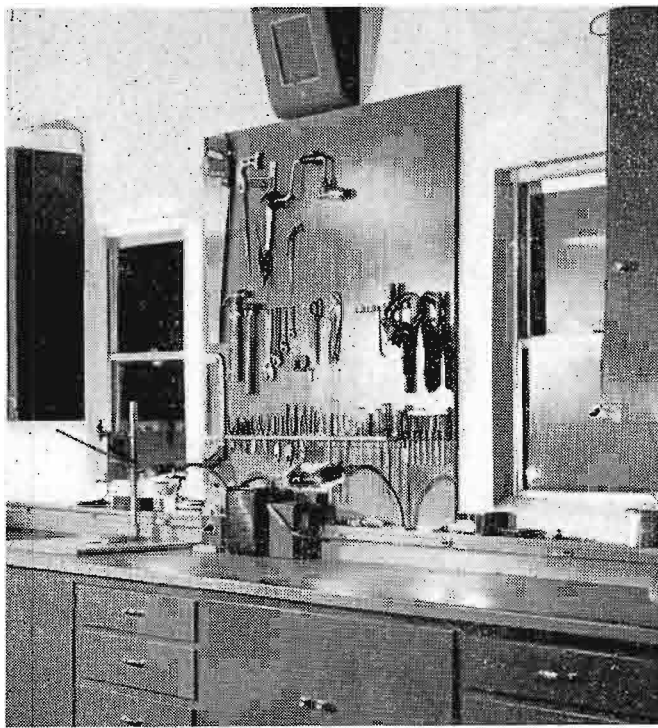

FIG. 4 (above). Partial view showing a portion of the work bench in WBCK's shop.

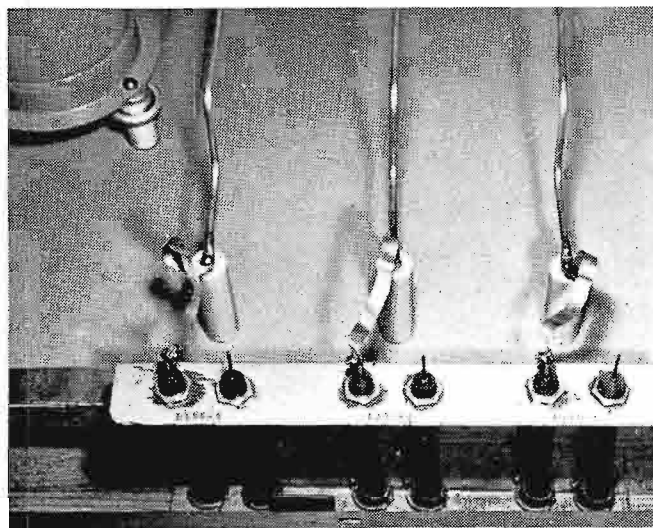

FIG. 5 (above). Closeup showing the output connections at phasing unit. Note lines run in duplicate and method of selection.

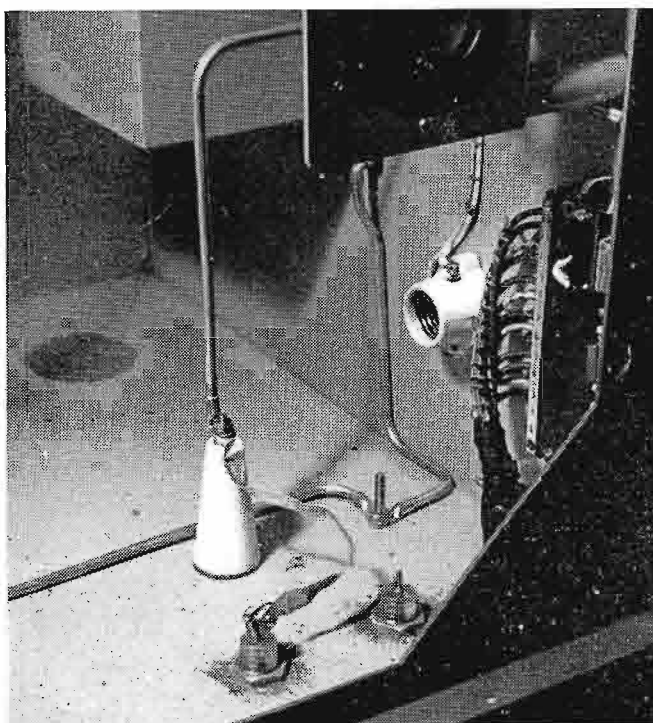

FIG. 6 (above). A coupling unit termination of transmission lines showing method of selecting the line desired.

in the center of the runs than at the ends, thus they drain into the manholes. The trenching in our instance was done with a power grader with a tilt blade, however, a regular trenching machine is to be recommended if obtainable. The grader cost us .30/foot to open and backfill our trenches to a depth of three feet. The four manholes were built with common labor and ran about \$25 each. The cable bundle consisted of the following: two 21-125 transmission lines; two RG-8/U sampling lines; three #6 "TW" lighting cables; one MHFA-14 control cable (Navy surplus 14 conductor armoured).

The cable bundle was pulled as a unit after first fishing a 1/2-inch rope through the conduit as a pull cable. The manholes made it possible to pull the long lengths required (two 250-foot runs and one 520-foot run).

Advantages of System

1. Easy installation. Entire cable laying operation required approximately four days. R-f cables can be handled like large a-c cables, therefore no skilled labor needed.

2. Low maintenance. No dry-air pump required. No splices, leaks, or special fittings to worry about. Water—no problem.

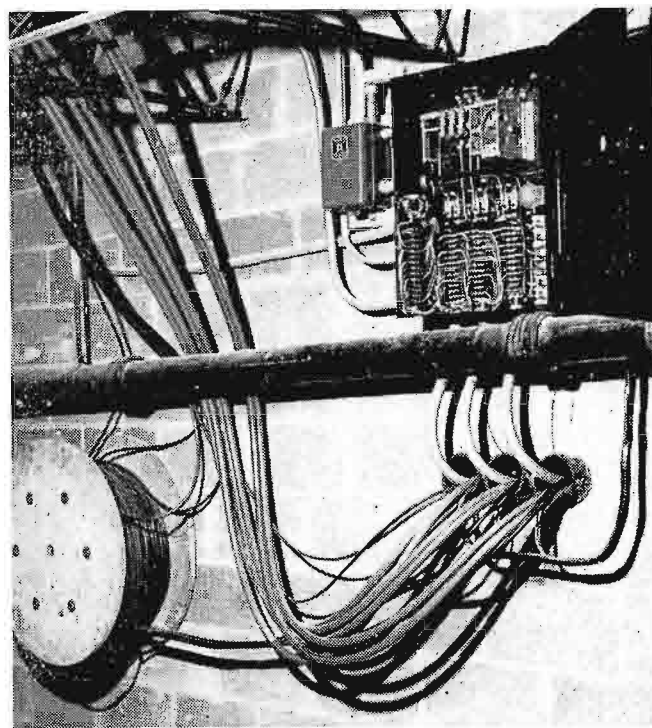

FIG. 7 (above). View of conduit entrance to building, junction box with tower light flasher, photo-electric motor starter, and (at left) reel of surplus sampling line from #2 and #3 towers.

3. Future alterations made easy. Use of large conduit allows cables to be pulled at will. Use of 21-125 cable good for powers up to 10,000 watts with ample safety factor.

4. 100% safety factor due to FCC requirements for duplicate r-f cables in underground installations.

5. Overall efficiency measured slightly higher than normally used air-type cable. (No absolute tests made, however, above was noticed by consulting engineer, A. F. Englis.)

6. Absence of cable runs above ground leaves area clear for producing a money crop such as alfalfa.

Studio Set-up

A floor plan diagram of the studio is shown in Fig. 9. We were limited as to room, having approximately 2000 square feet to work with. However approximately 1500 square feet additional room can be obtained in the future. It was therefore decided to design the studios and control rooms in their final form so that future expansion would consist only of providing additional office space. The theory back of this being that it is less expensive in the long run to outfit the space as studios and use some of it temporarily for offices than to have to convert offices to studios at some future date. Accordingly we are at the present time using studio "C" and Control Room #2 as offices. The music library is also in "C". The overall size of studio "A" is limited by the ceiling height and other structural factors present in the building.

The WBCK studios are located on the 4th floor of the 18-floor Security National Bank Building, the best constructed and most imposing building in Battle Creek. Sound treatment of the studios consists of Johns-Manville studio element covered with perforated Transite on the walls, and Johns-Manville "Fibertone" on ceilings. "Riverbank" doors are used on all studios and studio "B" is provided with sound locks. Studio "B" is also designed so that it may be converted into two announce booths by the addition of one wall. Recessed fluorescent lighting is used and studios are air conditioned by connection to the bank's system.

1 KW AM . . . W B C K

Battle Creek, Mich.

At present one RCA 76-B5 Console is used in the control room along with two RCA 70-D Turntables and a speech rack holding associated equipment such as cueing and recording amplifiers, etc. An eight-bay patch panel is used and is wired for the addition of a second 76-B5 Console in Control Room #2. All microphones, remote lines, auxiliary amplifiers, etc., are brought up to jacks for maximum flexibility.

Recording is done at present with two RCA 72-DX cutter attachments. When the second control room is installed, it will be equipped to handle all recording.

WBCK Mobile Unit

A simple but very effective mobile unit is used for all emergency and special events remotes. This unit consists of a station wagon equipped with a tape recorder, reels for extension microphone, a-c and telephone cable, and with an operating desk mounted in the rear for use of any other remote equipment desired. The heart of the unit is a simple 150 watt power supply providing 115 volts 60 cycle a-c for the recorder or remote amplifiers as desired. A vibrator inverter is run from a 12 volt d-c supply. The d-c is obtained by using a second six-volt battery in series with the car battery. A double-pole, double-throw switch allows this second battery to be paralleled across the car battery for charging. Use of the vibrator type inverter keeps the output frequency constant regardless of input voltage and is the reason the system works so well. We cut tapes in the mobile unit and play back on the studio machine with excellent results. The above system has been in operation for six months with no trouble of any kind. It permits us to cover emergency remotes "on the run". Two-way radio is to be added at a later date.

Staff

The engineers who helped materially in the above installations are: William McLellan, Wendell Crum, Robert Wilbur and James Tinsler. All design, supervision and organization during the construction period was handled by the chief engineer.

The president and general manager of WBCK is Mr. Robert H. Holmes, local Buick dealer.

FIG. 8 (at right). Studio engineer, Leo Jylha, shown at control of RCA 76-B5 console located in control room #1. Note KB-2C bantam microphone mounted on special arm.



FIG. 9 (below). Floor plan of WBCK studios A, B and C which are served by control rooms #1 and #2.

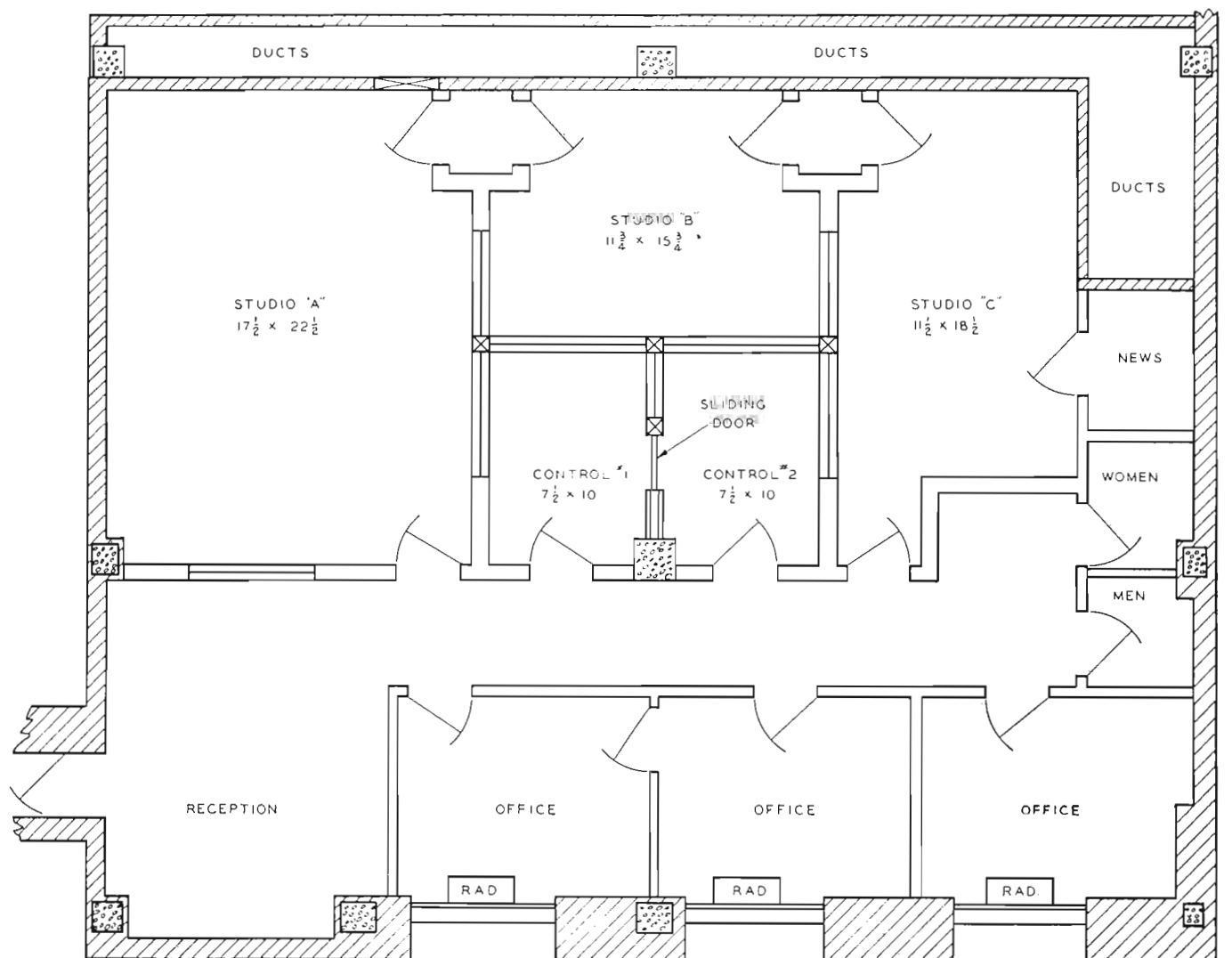

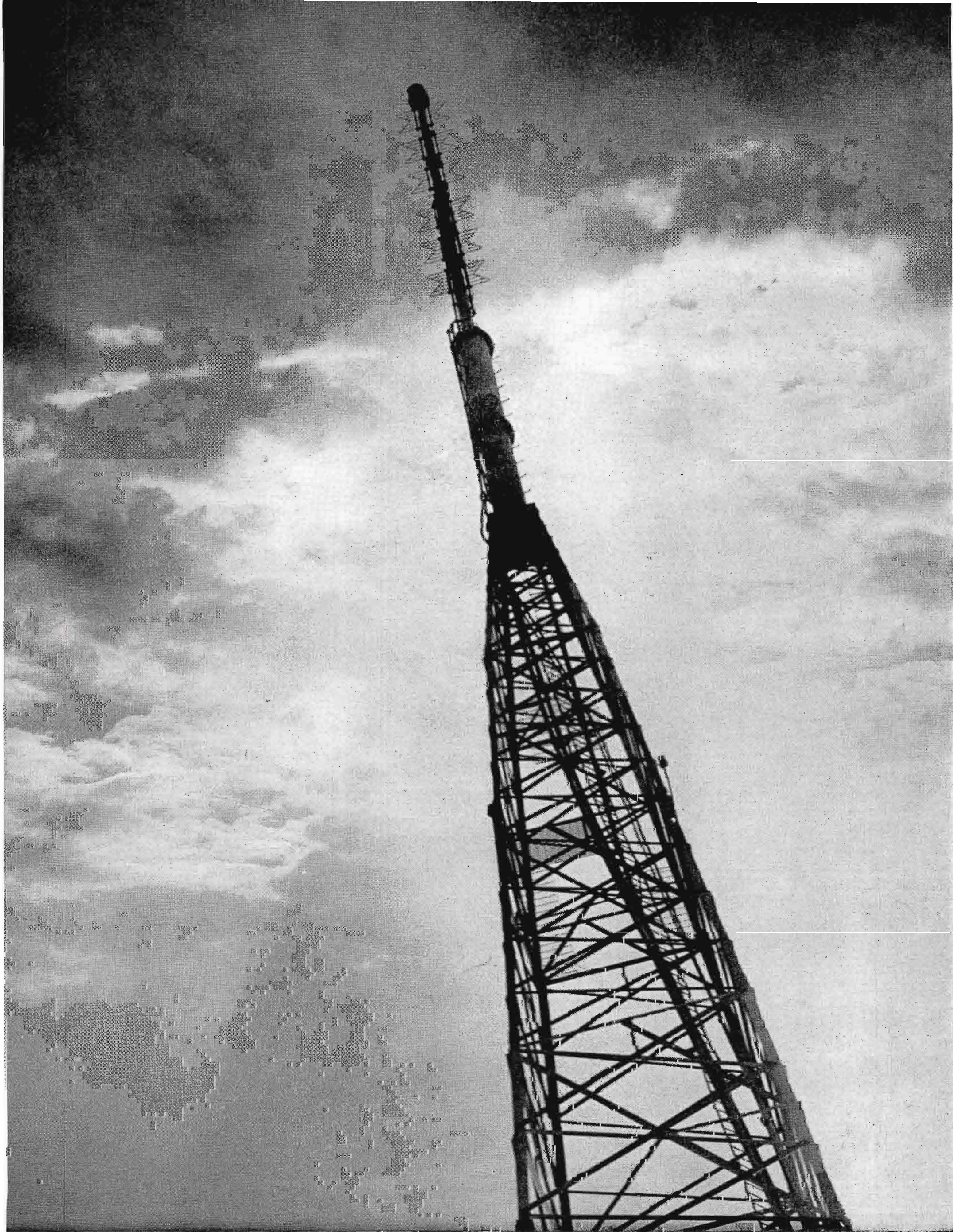

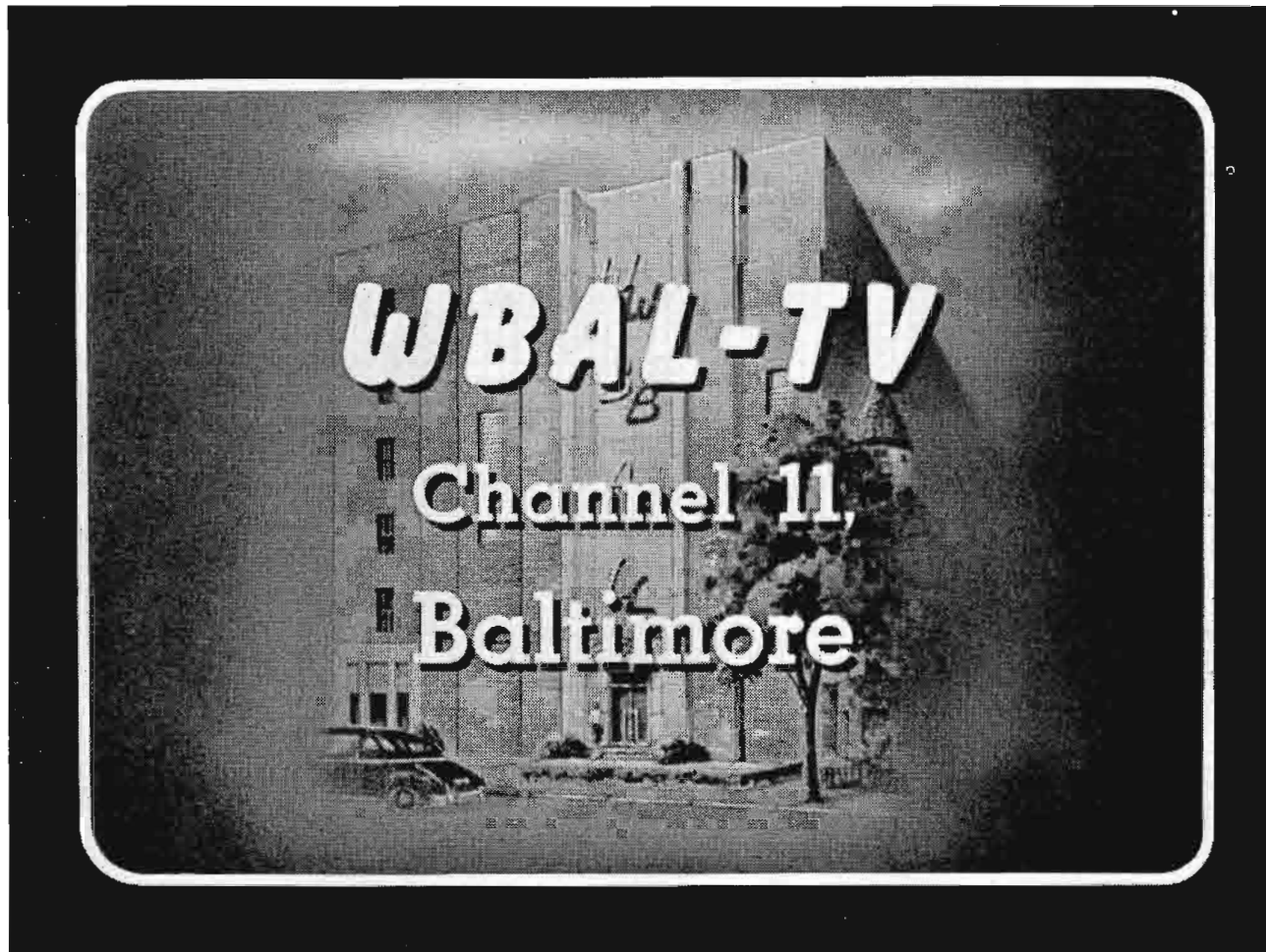

FIG. 1. The WBAL-TV tower, shown at left, has an overall elevation of 447 feet. A two-section Pylon Antenna supports a six-section Superturbo-stile for television.

By W. C. BAREHAM
Chief Engineer

Back in December of 1947, BROADCAST NEWS carried a story on WBAL's "New World of Tomorrow Studios" which described in detail the AM broadcasting facilities of our station. Since then, we have gone on the air with television and now we have another story to tell.

WBAL-TV made its formal debut on March 11, 1949, amid the usual fanfare that attends a station's opening. The station was given a send-off by the National Broadcasting Company in New York, and

by its affiliates in Philadelphia, Washington and Schenectady. The programs were sent to our station via radio relay. The first local program, however, was a live show originating in the WBAL "Air Theater."

WBAL-TV was the nineteenth television station to go on the air. We are quite proud of our equipment and facilities especially since WBAL-TV is one of the few stations in the country that can put

on audience participation shows from its own studio with full stage effects.

Licensed to Hearst Radio, Inc., and affiliated with the Baltimore News Post, the station is now on the air sixty hours a week with an effective radiated power of 27.2 kilowatt visual and 13.1 aural.

The television studios are located at 2610 North Charles Street, about two miles from the center of Baltimore, in the five story modernistic WBAL building.

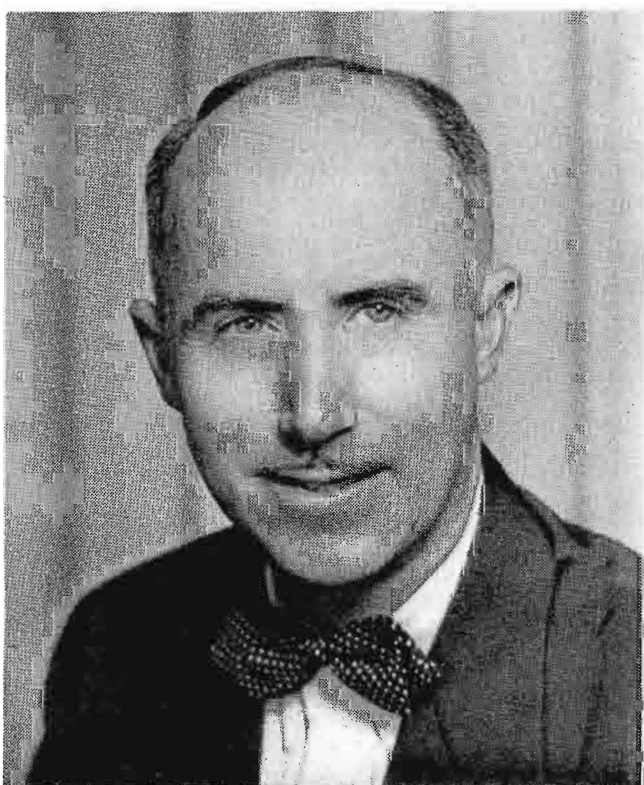

FIG. 2. William C. Bareham, a native of Baltimore County, Maryland, is an old timer at WBAL. He has been with the station for twenty-two years, and is now Chief Engineer. For ten years previous to joining Station WBAL, he was a radio operator in the Merchant Marine.

FIG. 3. Harold C. Burke, Manager of WBAL and WBAL-TV, has been in radio for twenty years. He joined WBAL in 1938, having been manager of Stations WISN and WTSA for ten years. Prior to entering radio, he was affiliated with three of Wisconsin's leading newspapers.





FIG. 4. Scene in the "Air Theatre" taken during one of WBAL's audience participation shows. This large Air Theatre, also known as Studio E, is often used for combination AM and TV programs. Control room window is located at extreme left (under clock).

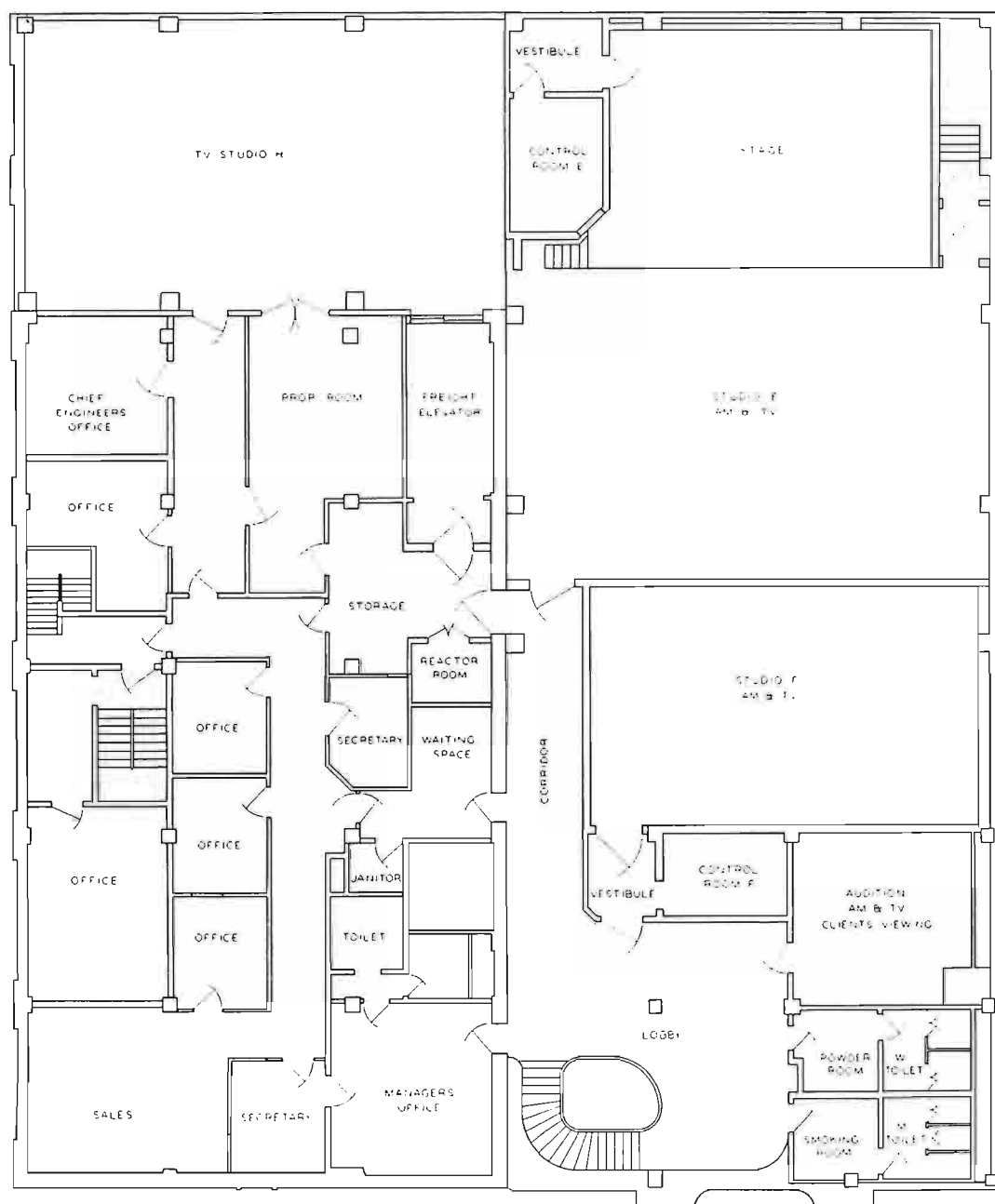

While the station has nine studios incorporating the latest in acoustical design, only two of them are primarily used for television. One of these is designed exclusively for TV. Local originations, both film and studio, comprise about fifty percent of our weekly program. The remainder of the schedule is devoted to network operation.

The "Air Theater", studio "E", located on the second floor of the studio building, is one of the largest and most modern studios of its kind. It is used for combined AM and TV shows and is very similar to the NBC studios in Hollywood and New York with a large stage and with a seating capacity of 160. This is where the "Hi-Jinks", combination AM and TV show, is produced (Fig. 4).

Studio "H", the main TV studio, is also located on the second floor of the building. From all appearances, studio "H" resembles one of the soundproof movie sets in Hollywood. The studio is 50 feet long by 30 feet wide and is two stories high. One end of the large studio is a perfectly furnished Georgian room. The

◀ FIG. 5. The second floor of WBAL's studio building, as shown at left, houses the main TV Studio H, the "Air Theatre" shown above, and an auxiliary TV Studio F.



FIG. 6. Newly installed banks of fluorescent lights, used in conjunction with incandescent flood lamps, provide the illumination for Studio H. Photo shows one corner of the well appointed "Georgian Room."

furnishings in this "set" include pieces of furniture suitable for living room scenes and is complete with fireplace, piano, and comfortable setting for plays and interviews.

Thirty-six feet of ceiling-to-floor draperies cover part of the walls of the other side of the room. This is used as a back drop for variety shows, ballets, musicals, and similar programs. Various decorative props have been constructed so that portions of the curtain may be transformed into different sets.

High around the ceiling, treated with acoustical celotex, are newly installed rows of fluorescent lights. The new system is made up of 16 foot fixtures with two 8 inch warmtone lamps. It provides 180-foot candles of overhead lighting. With this system, enough incandescent light will be used as side lighting to provide depth and roundness to the television picture. This light greatly favors the RCA Type 5820 Image Orthicon Pickup Tubes, which incidentally, we intend to standardize for both studio and field purposes.

FIG. 7. The television control room is located on the third floor of WBAL overlooking Studio H. As shown in plan, the film projection facilities are situated in an adjoining room.

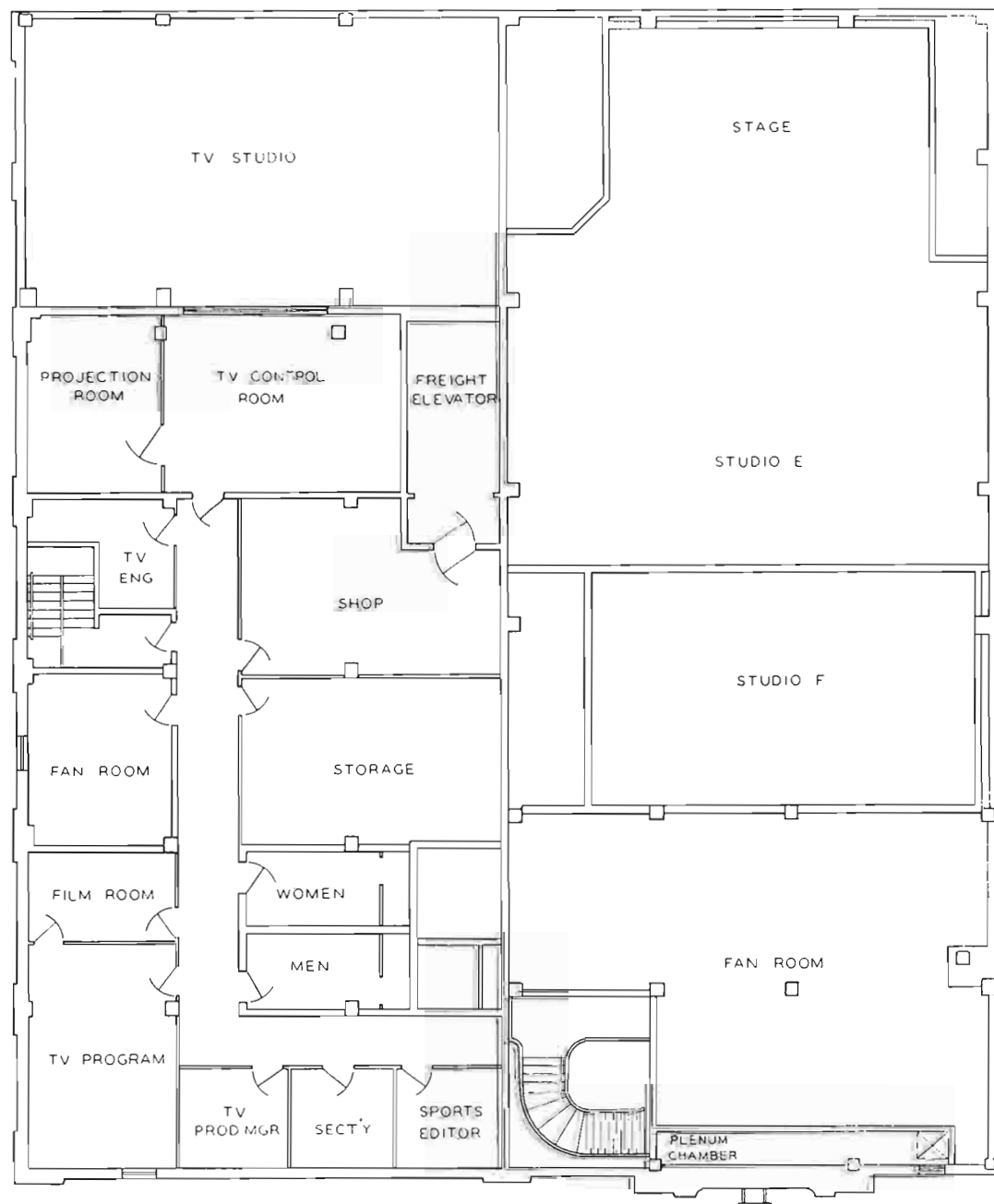

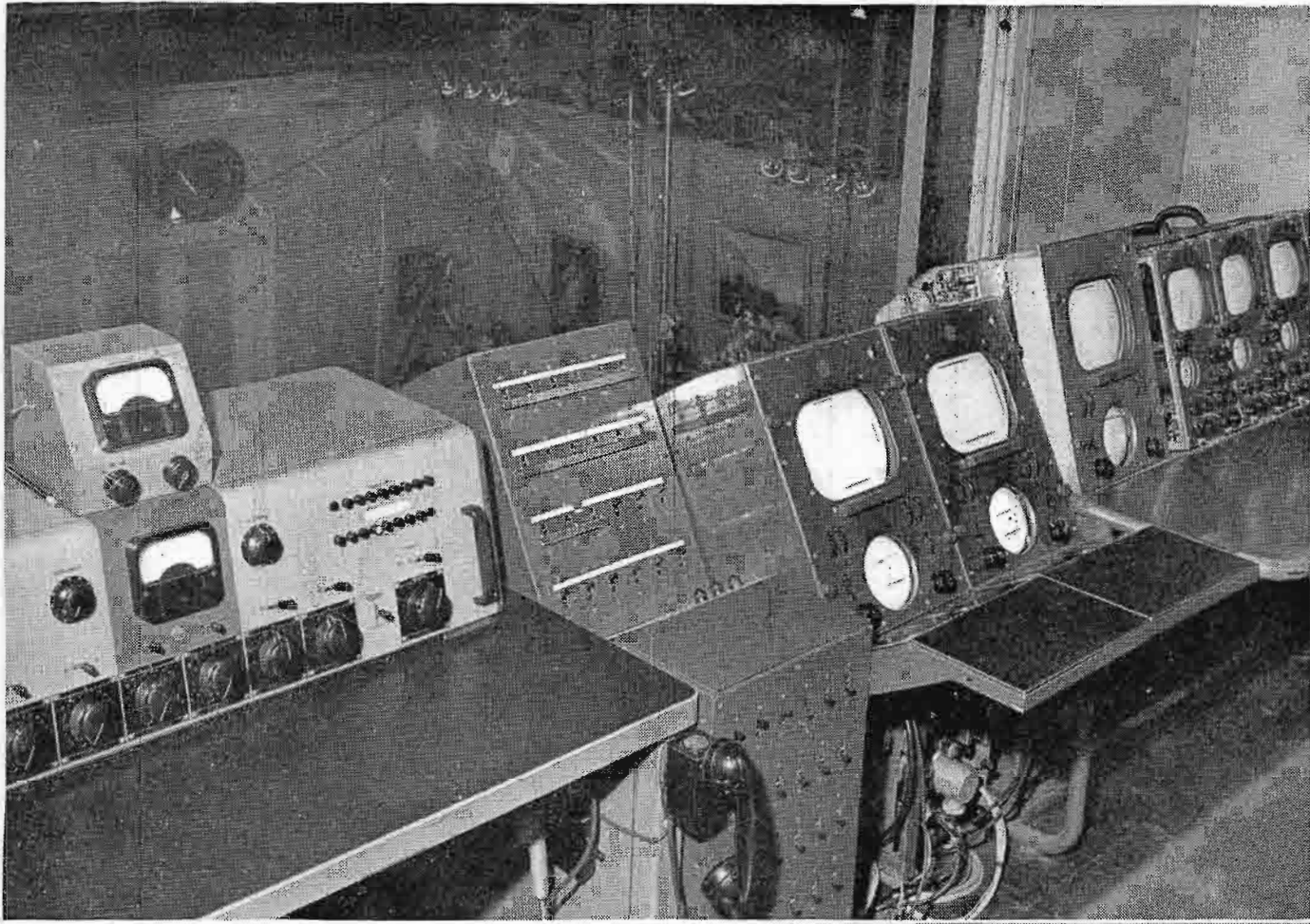

FIG. 8. Audio and video control equipment installed in front of TV control room window overlooking Studio H. All TV and some AM program switching is accomplished at a switching panel on a raised platform shown at lower right in photo below.

FIG. 9. View of WBAL's TV control room showing edge of director's platform and program switching position (right), and AT&T network terminal board (left of equipment racks). Photo shows R. Melvin Quinn, TV production manager (seated at the AT&T board), and Louis P. Wagner, TV supervisor.

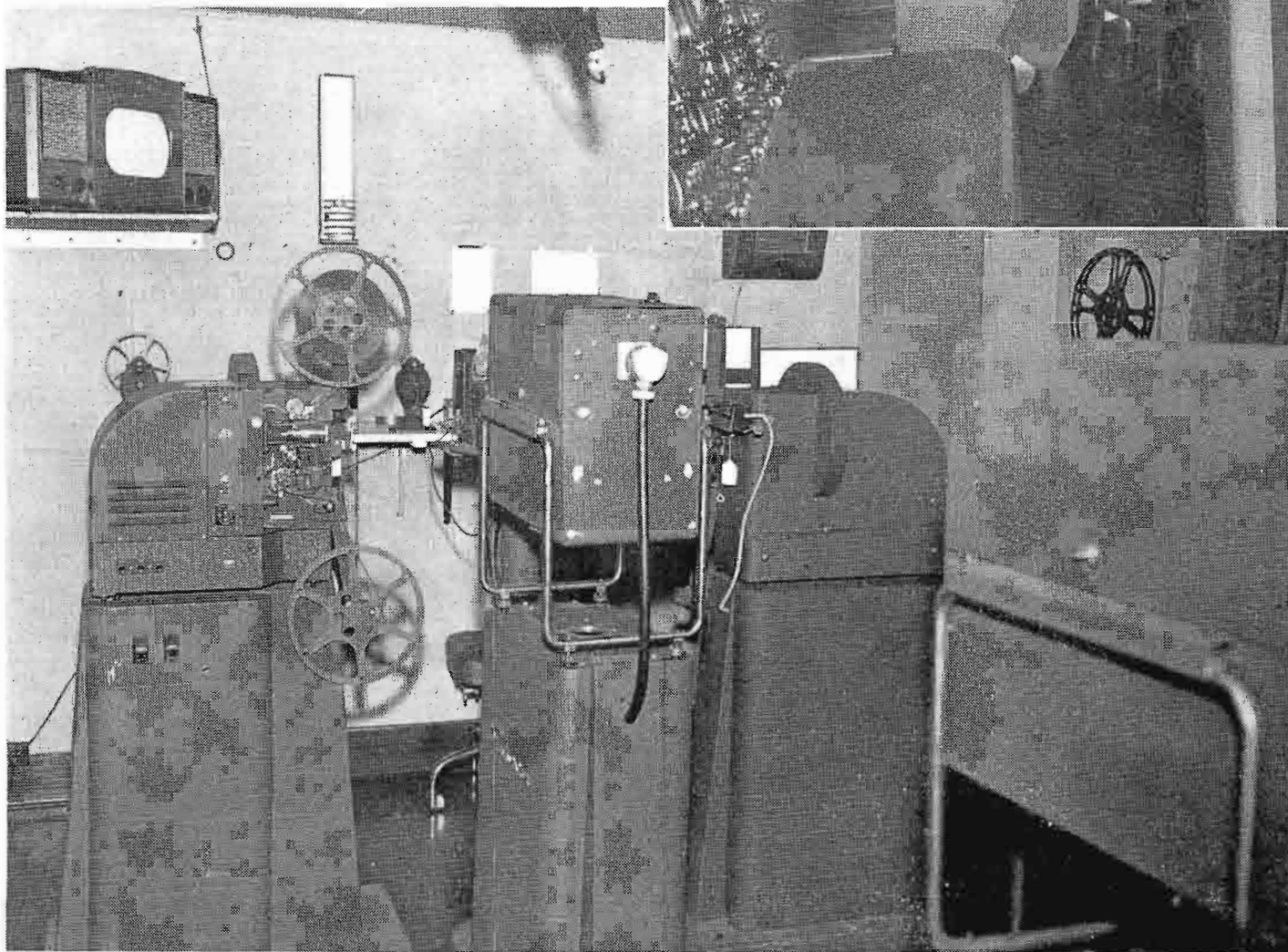
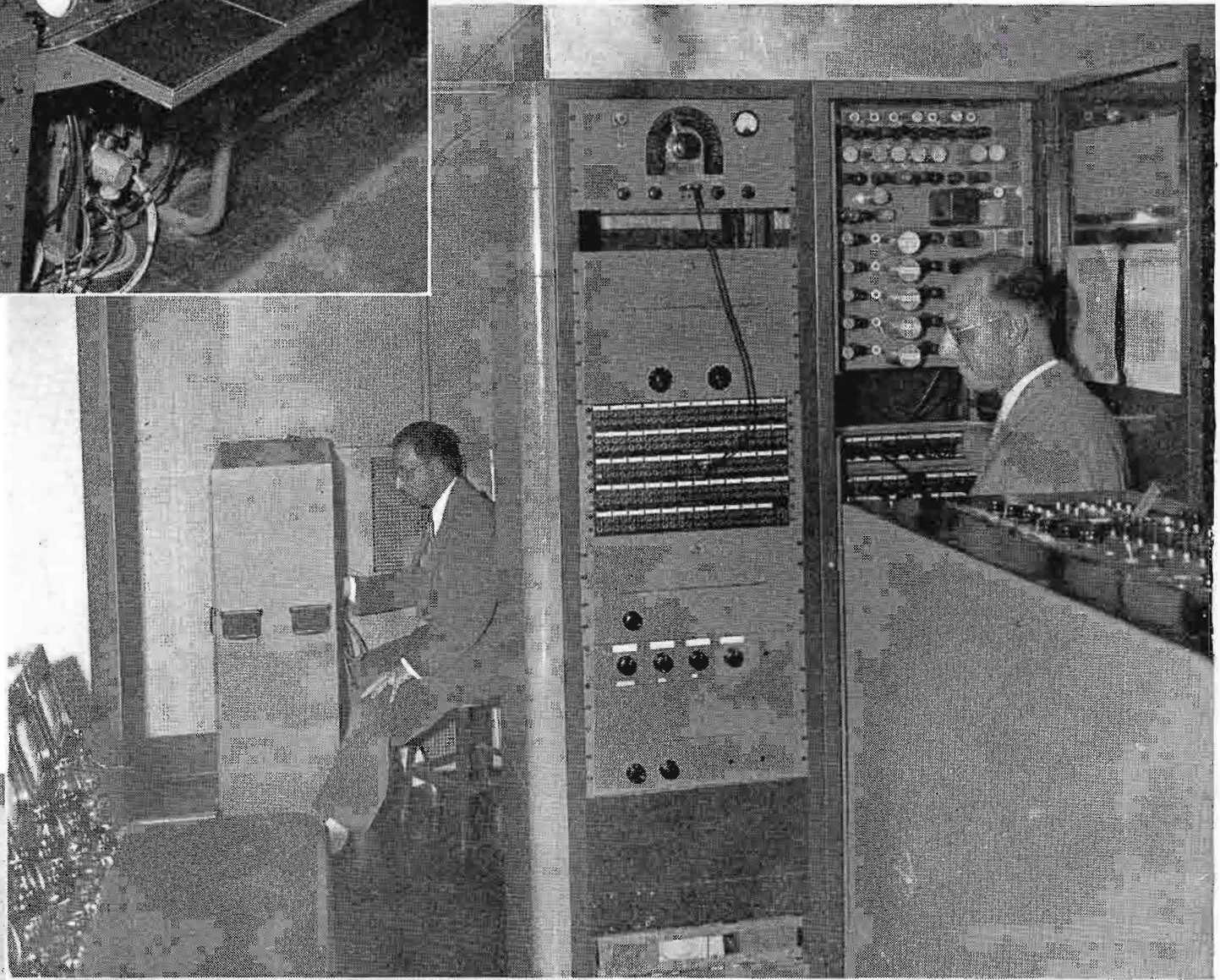

FIG. 10. Projection room facilities include two sets of 16mm projectors and two film cameras. One film camera is just visible in the photo. The projection monitor (upper left) is a converted RCA TV receiver.

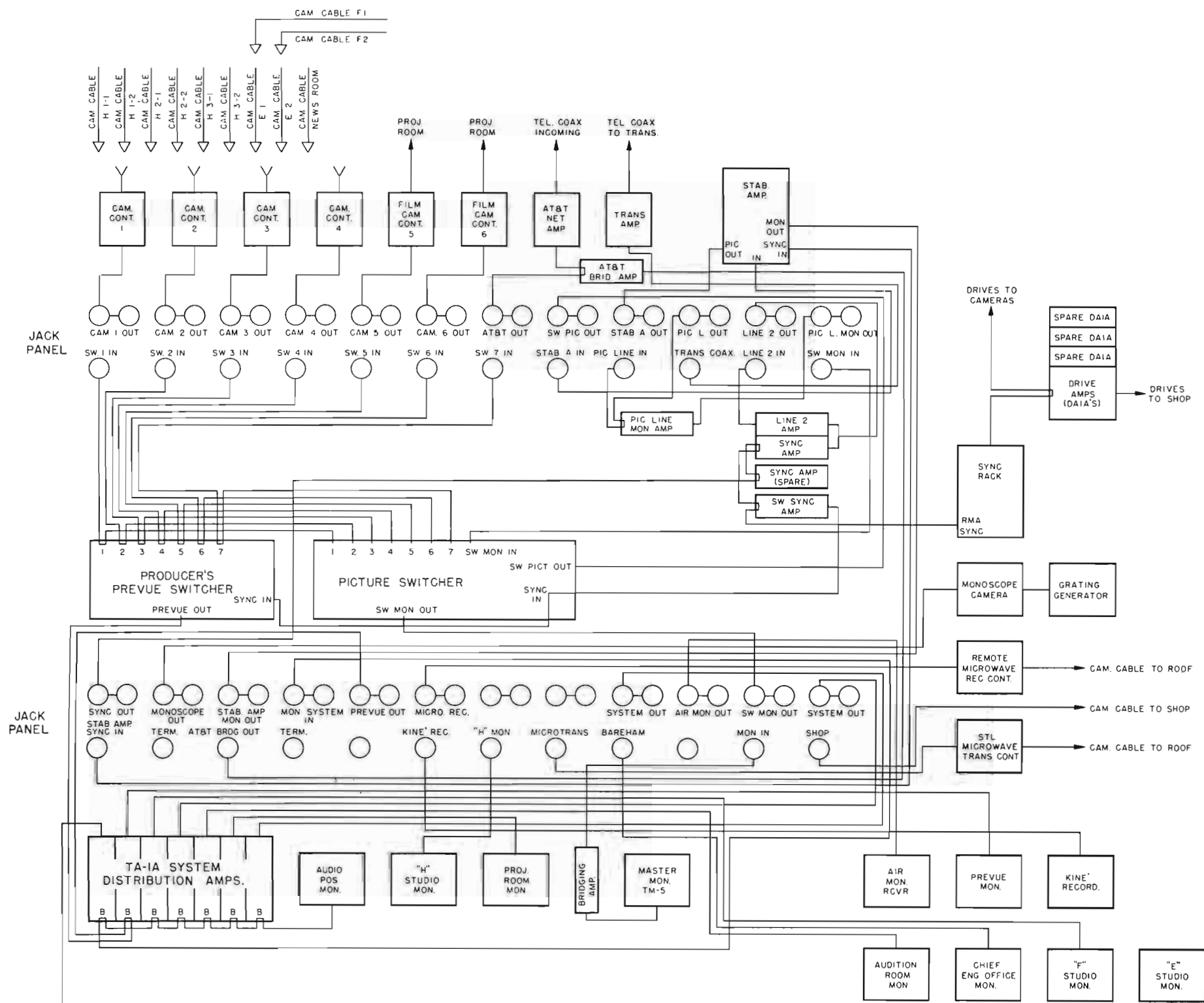

FIG. 11. Block diagram of complete TV audio and video facilities. A system of jack panels in combination with separate systems for preview and program switching affords great flexibility in programming.

With the addition of the new fluorescent lighting system, the electrical power consumption has been cut in half, reducing operation costs. Equally important is the fact that these cooler lights greatly reduce the drain on the cooling system and provide added comforts to the program participants.

RCA Image Orthicon field-type cameras are used throughout WBAL-TV. The main studio is equipped with two cameras: one mounted on a tripod and dolly; the other on a pedestal. The pedestal provides a greater degree of flexibility for studio work in panning and tilting the camera. In all, four camera chains are used by WBAL-TV.

During the construction of the AM studios WBAL made provision for the future installation of television facilities. In addition to interconnecting cables for the normal AM operation, the station installed

television coaxial cables within 4-inch conduits in the wiring trunks. These cables which terminate in coax-connectors are installed in the studio walls. This system permits operators to pick up television programs in any one of the studios "E", "F", and "H", and "pipe" them to the control room. The coax outlets enable the cameras and monitors to be plugged in directly into the system as easily as one plugs a patch cord into a jack panel.

All told there are six camera cables for "H"; two camera cables from "E"; and two from "F" through "E". At present studio "F" and the newsroom are occasionally used for TV production such as in interviews.

The TV control room and projection room are located on the third floor of the building (15 feet above the floor of studio "H"). TV production and engineer-

ing facilities are also located on this floor. The control room which measures 25 feet by 18 feet is centrally located on one side of and overlooking studio "H", the main TV studio. This control room houses monitoring and control equipment for cameras, film projectors and other sources of TV.

Equipment consists of an RCA Audio Console Type 76, an auxiliary VU meter position for monitoring an additional audio channel, an order wire and program switching system, four portable field type camera controls, two of which may be removed for making field pickups, two film camera controls and a master line monitor. Audio and Video control units are located in front of the control room window overlooking the TV studio. The program switching system is built into the program and technical director's desk which is elevated about two feet above the control



FIG. 12. The modern transmitter building contains a garage for Mobile Unit, workshop, office, kitchen, and the transmitter room. Feed lines, supported by several sturdy poles, are routed up the tower (left) to the 6-section Superturnstile.

room floor. From this position the technical director who does the camera switching and the program director have a good view of the studio performance.

TV programs as well as AM sound from the various studios are all terminated in jack panels in the control room. This ar-

angement enables any TV or AM program to be routed to the television transmitter and to the network lines, audition rooms, offices, or other studios.

The TV switching system (Fig. 8) consists of separate banks for previewing and program switching. Each television

program source can be previewed prior to switching to the program line. Provisions are also made for routing sound to and from any of the AM studios to the TV transmitter and to network lines which are terminated in the control room. The control room is rock-wool insulated. The walls are finished with acoustical celotex.

Adjoining the TV control room is the projection room which houses two complete film camera chains and includes two 16mm motion picture projectors, four slide projectors, and a balopticon system for televising cartoons and commercials. All power supplies, as well as the camera controls for the film cameras, are located in the control room. A converted RCA 630TS television receiver mounted on a shelf in the projection room is used as a line monitor. It might be added here that several modified RCA receivers are used in the studio building at various points such as offices and audition rooms for program viewing.

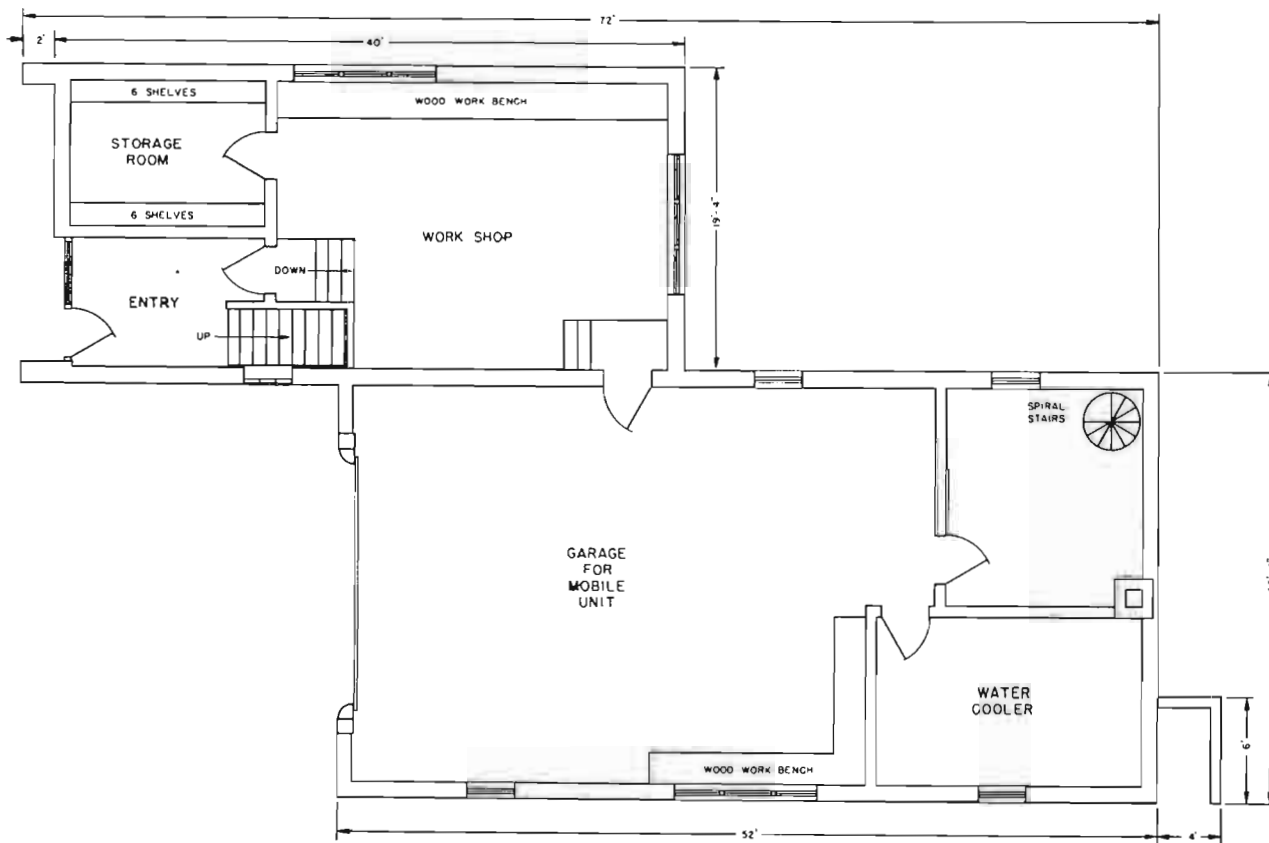

FIG. 13. The first floor of the transmitter building, shown in Fig. 12, houses the mobile TV unit, a well-equipped workshop and air conditioning equipment.



FIG. 14. TT-5A 5KW transmitter and equipment racks of WBAL-TV. Transmitter room also houses the transmitter console, an LC-1A monitoring speaker and modified RCA TV receiver for network viewing. Photo shows TV technicians Arthur Denische (seated at console) and Harrison Brooks.

In addition to the live studio programs, WBAL-TV makes use of the following source of programming material: network programs, remote pickups via microwave relay transmitter from mobile truck at scene of events, motion picture films, and kinescope recorded programs. WBAL-TV has access to independent relay facilities between New York and Washington through an NBC Microwave relay link. Transmitter of this link is installed at Cub Hill, Md., feeding WBAL-TV and next hop on link to Washington simultaneously.

We have tried experiments with the use of unattended cameras for the interview type of program and have been very successful. This is usually done on weekends when the operating staff is limited. The two cameras, set up prior to show time, are focused on the center of pick up and locked into position for the duration of the show. Two men are required in the TV control room; one man at the switcher to

switch between these cameras; and another operator on audio control to handle audio levels. (Editor's Note: Unattended operation of cameras not recommended because of danger of burning image into target of tube.)

WBAL's operating crew consists of twenty-two men for both AM and TV. Twelve of these are required for television operation. Of this number, seven are used in the control room; one operator for the camera controls used in studio and film

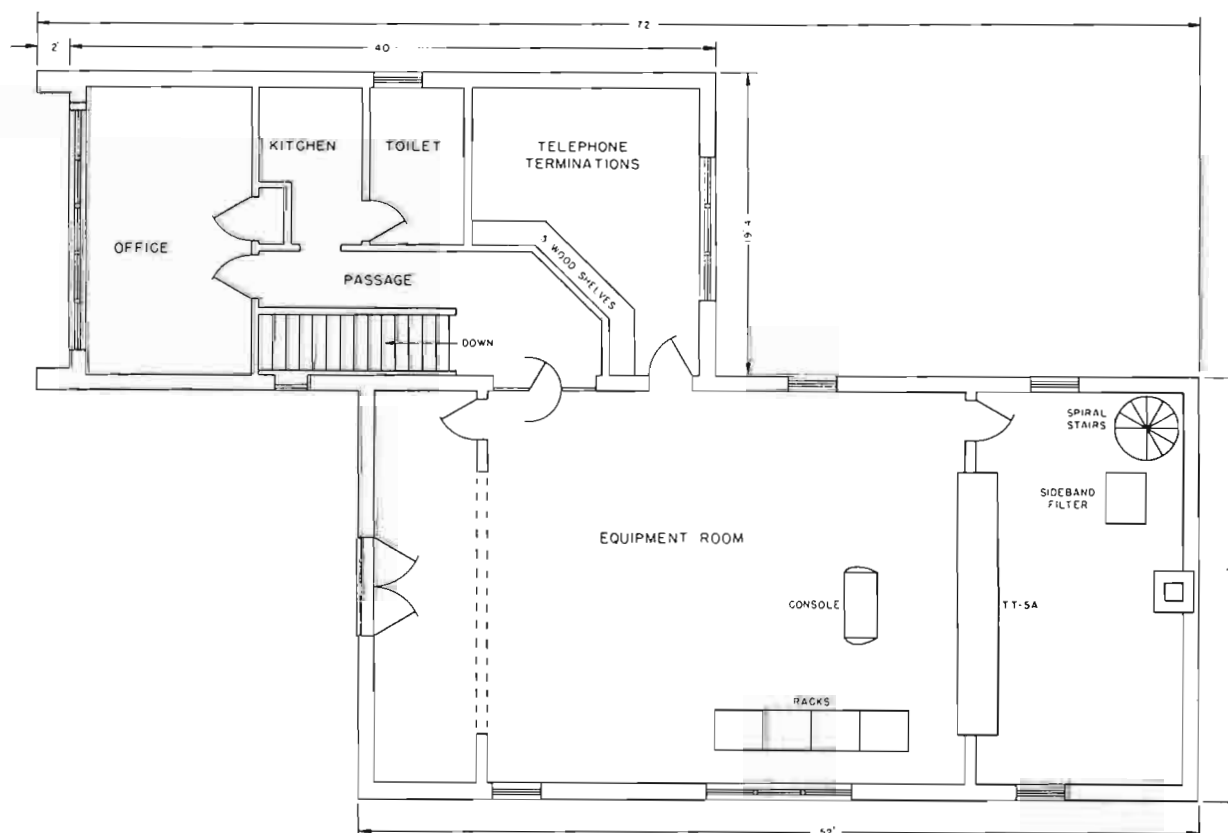

FIG. 15. This floor plan shows the arrangement of the flush-mounted TT-5A transmitter, the sideband filter, the racks, and other facilities of the transmitter building.

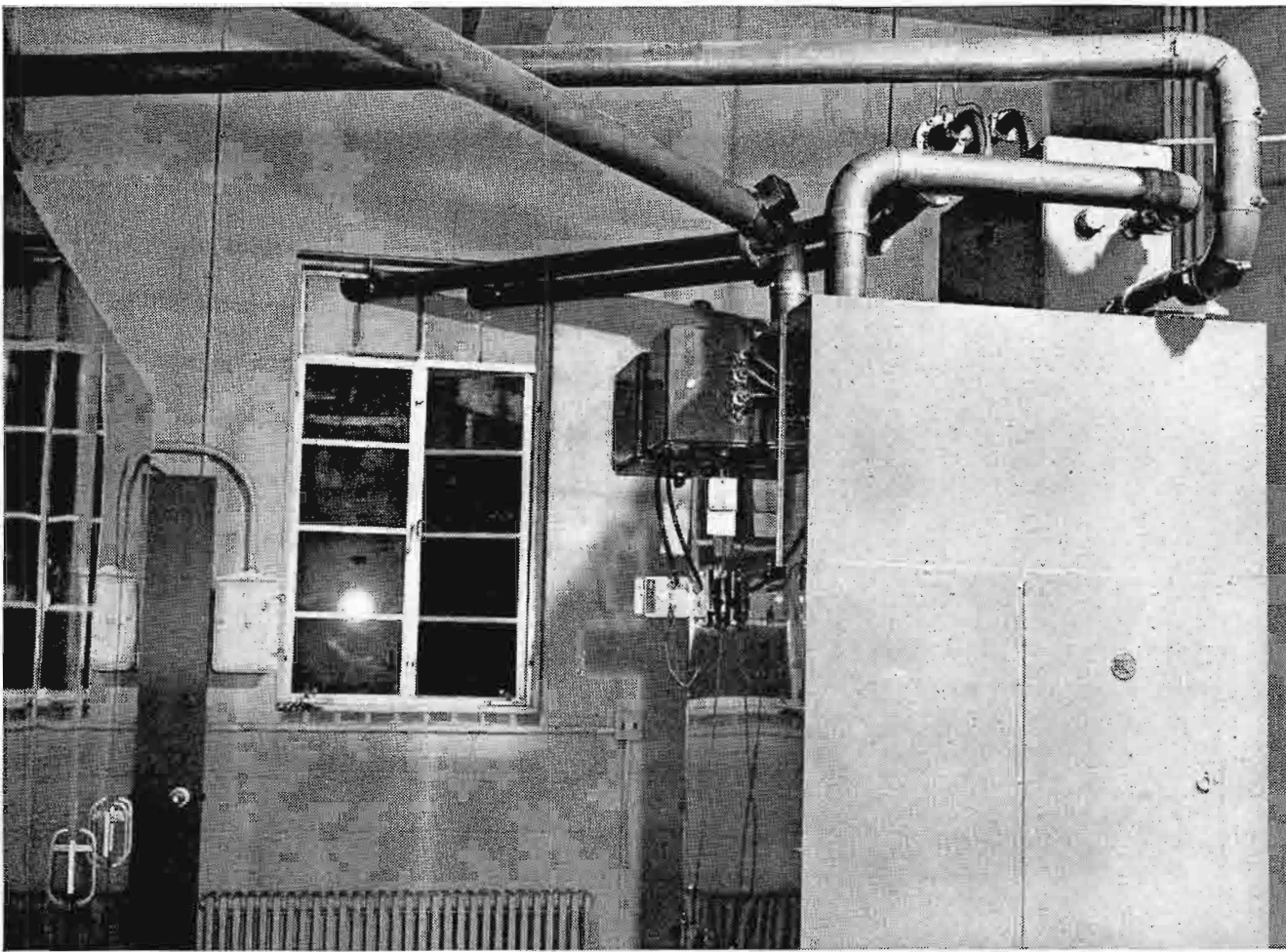

FIG. 16. Vestigial Sideband Filter (at right), diplexer (on top of the filter), and WM-12A and WM-13A demodulators for monitoring, are installed behind the 5 KW transmitter shown at left.

cameras; a switching operator; a film operator or projectionist; and an audio control operator. For studio pickup, we usually use two camera men and one microphone boom operator.

The video signals from the studios are sent to the transmitter site via the use of microwave relay equipment. The programs are fed, via coaxial lines, to microwave relay transmitters on top of the five-story building. The programs are then "beamed" to the transmitter on 6900-6925 megacycles. The microwave relay receiver is situated on the top of the transmitter building. We find that microwave relay equipment is very reliable and has excellent frequency response.

The television transmitter and tower are located in the northwest section of Baltimore at Violet and Cottage Avenues, approximately three miles from the studio. Overall elevation of the transmitter tower is 851.2 feet mean sea level and 446.7 feet above the ground level. It is one of the tallest structures in Baltimore. The antenna proper is a six-section television Superturnstile Antenna supported by a two-section RCA Pylon for FM (Page 72). The tower is located about fifty feet from the transmitter building, which is a modernistic two-story structure, constructed of cinder blocks and steel reinforced concrete (Fig. 12).

The first floor of the building houses the garage for the mobile television unit, a fully-equipped workshop, and air-conditioning equipment. The second floor is outfitted with an office and kitchen for the operating personnel. The TT-5A, RCA five kilowatt television transmitter, and five equipment racks, containing power supplies, amplifiers and input and monitoring facilities, are located in the transmitter room. The transmitter is flush-mounted in a wall (see Fig. 14). Behind the transmitter are the sideband filter and an exhaust duct and fan for ventilation of the transmitter. Warm air is expelled through the top of the building.

The control position in the transmitter room consists of an RCA standard control console for the TT-5A plus a program switching system which enables the transmitter engineer to switch between network and microwave relay.

Supervisory personnel at WBAL-TV include the following: Harold C. Burke, Manager; D. L. Provost, Business Manager; W. C. Bareham, Chief Engineer; Willis Friert, Program Director; Louis P. Wagner, Jr., Supervisor; and R. Melvin Quinn, TV Production Manager.



FIG. 17. 5,000 and 500 microvolt/meter contour lines of WBAL-TV. Small semicircles indicate towns outside the 500 microvolt/meter area reporting good reception.

WTND	WISL	WHTN	WBCK	WJMJ	WBUT	WWHG	CKMO	CKNW	CHAT	CKNX	CKTB
WACO	KLMS	WHFB	KOWH	WNAM	WHVR	WBCU	CJIB	CJCJ	CKPR	CHNO	CFRA
WKRK	KFXM	WJPG	KLER	WACB	WELI	WROK	CJAT	CKUA	CHEX	CFCH	CHOV
KWYO	WEEU	KVCV	KTXN	WLXW	KPRS	CKVI					CKOY
WKNA	WBMD										CBJ
WACE	WSAC										CJFX
WALT	WLVA										CKBW
WAPX	WLCR										XEZM
WLBR	WKTY										XEBS
WKMJ	WSLS										PRI-2
WTAC	KSPR										PRI-8
WGL	KOVO										PRE-5
KGIL	WLAK										CMHD
KSBW	KVEC										CMBF
KSCO	WIMA										KMVI
KGCU	KX-RX										KIPA
WBOC	WVOT										TIFC
KVVC	WNOW										XEBP
WTHI	WMFD										XECQ
KVOA	WEOL										KHBC

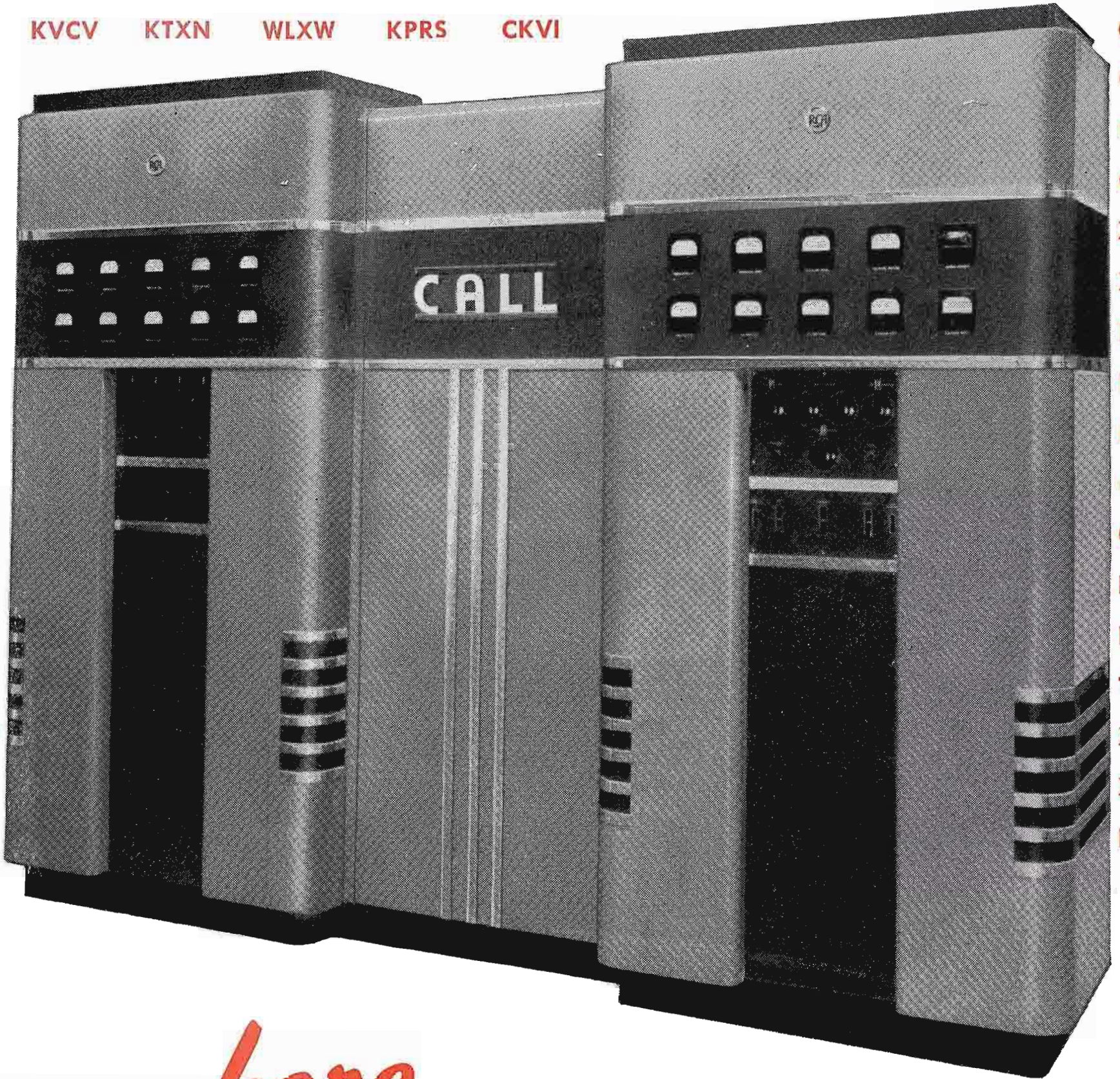

RCA 1-kw AM
transmitter,
type BTA-1L

Everywhere you look... **RCA 1-kw AM's**

SO QUIET in operation you can make announcements right in the transmitter room itself*, type BTA-1L maintains its excellent reputation for economical and reliable service by continuing to prove it.

Ask any station man who runs one. For complete data and suggested floor plans, see your RCA Broadcast Sales Engineer. Or write Dept., RCA Engineering Products, Camden, N. J.

**The BTA-1L uses no blowers or a-c contactors.*



**BROADCAST EQUIPMENT
RADIO CORPORATION of AMERICA
ENGINEERING PRODUCTS DEPARTMENT, CAMDEN, N. J.**

In Canada: RCA VICTOR Company Limited, Montreal

EVERYTHING IN LIGHTING.

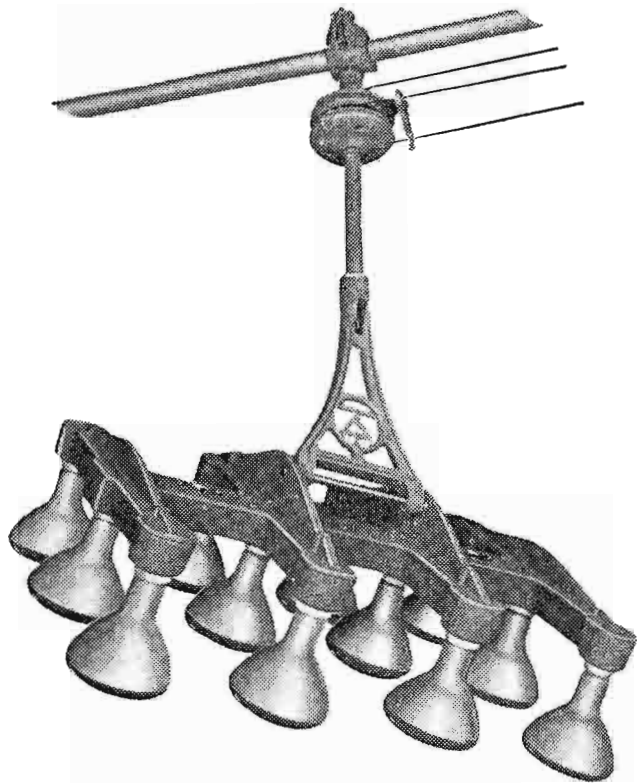

Incandescent Lamp Bank, Type TL-5A

The standard 12-lamp light source for normal studio operation. Ideal for slow fades. Provides equal light distribution on "douses." Maximum load per circuit, 3 kw; Per unit, 6 kw. Single cast aluminum-grille construction. Rotates 360 degrees. Tilts 170 degrees. Noiseless controls.

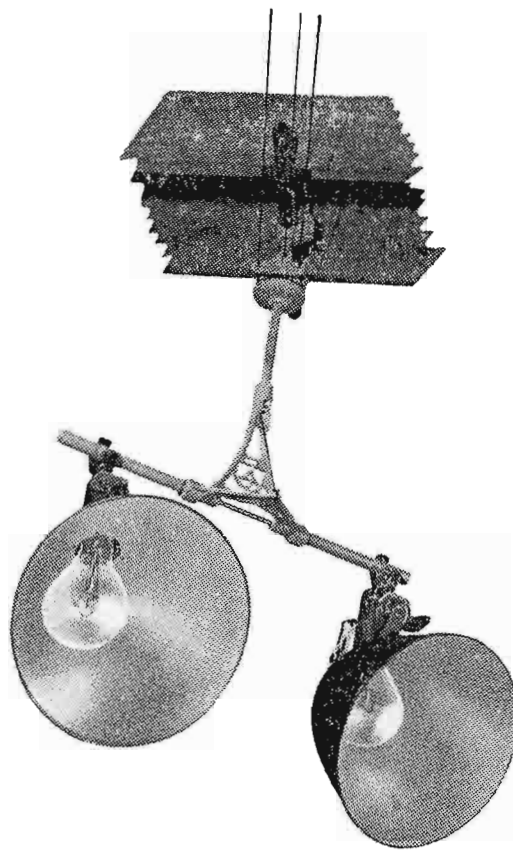

Rotatable Lamp Mount, Type TL-15A

With extension bars for mounting individual or multiple flood lamps. Control spindle can rotate 360 degrees—tilt 170 degrees about the point of support.



Fairleads, Type TL-32A

A practical way to guide mechanical control lines to control board without noise. 170-degree tilt and 360-degree angle of rotation around its point of support provides maximum flexibility for mounting anywhere. Equipped with quick-release gridiron clamp. Nine chromed bushings reduce control-line friction.

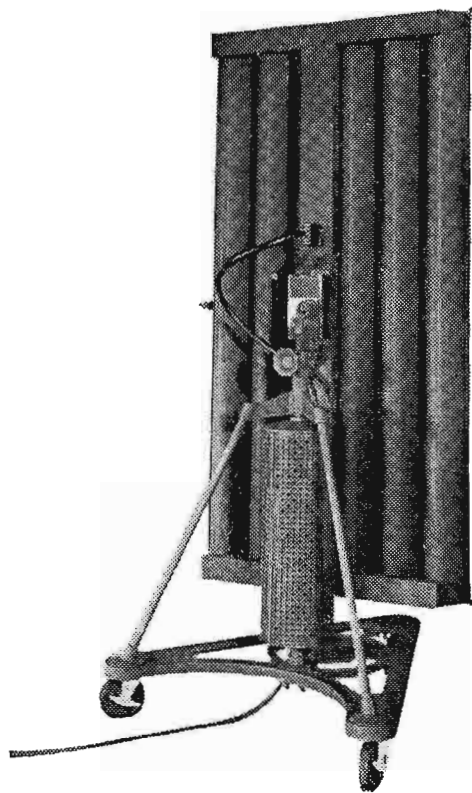

High-Intensity Light Dolly, Type TL-26A

The ideal mobile floor unit that puts high-intensity side illumination where you want it. Uses the TL-1A High-Intensity Fluorescent Bank. Rotates the bank from horizontal to vertical position; tilts it through 90 degrees. No high-voltage floor cables, because lamp ballast is right on the dolly.

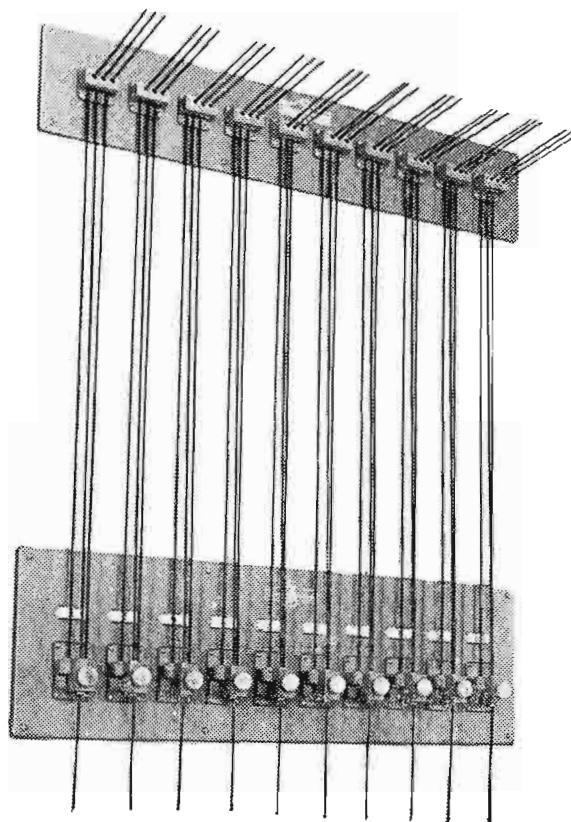

Light-Control Panel, Type TL-31A

Includes ten headlocks and ten rope locks for controlling ten light banks. Available in single units or on ready-to-operate panels, as illustrated.



Spot-Light Fixtures, Type TL-10A—TL-11A

Standard control spindle for use with a Mole-Richardson or Oleson 2-kw Solar Spot, or a 750-watt Baby Spot. Rotates 360 degrees. Tilts 170 degrees about its point of support.

FOR TV STUDIOS...

New silent-control lighting equipment enables you to "tailor" the lighting system to fit your studio—correctly, without expensive experimenting.

AVAILABLE for the first time—a complete line of studio-tested lighting equipment from a single manufacturer. Available for the first time—packaged studio lighting systems to match the response curves of modern studio cameras.

Combining high-intensity fluorescent banks, high-intensity spots, and incandescent banks for handling any studio set-up, RCA lighting systems are capable of delivering more than 200 foot candles of light energy. All lights can be rotated 360 degrees horizontally and 170 degrees vertically. All lights are designed for pyramid-mounting on studio ceilings. All lights are mechanically controlled through silent-operating fairleads that terminate in a central control board.

With this lighting equipment you can swing each light for basic work, modeling, or back lighting. You can direct each light to more than one acting area. You can "dim" by tilting, rotating, or cutting off half banks—and without upsetting light distribution. All equipment and wiring is off the floor. No ladder hazards or expensive catwalk installations. No danger of burning artists or technicians.

Here is the system that delivers correct illumination with as little as two-thirds to one-half the usual amount of equipment—and with proportionate savings in power. No more experimenting for the individual studio. No more junking of extensive lighting installations.

For help in planning your studio lighting—correctly—simply call your RCA Broadcast Sales Engineer. Or write Dept. 19IA, RCA Engineering Products, Camden, N. J.





High-Intensity Fluorescent Bank, Type TL-1A

Assures optimum light response from TV studio Image Orthicon cameras. Uses six 3500-4500 Kelvin slim-line tubes. Only 600 watts connected load. Includes noise-free, double-rubber cushioned, built-in ballast units; heavy-duty jumper cord connections; instant start high-voltage striking circuit. Uses pre-focused individual alzac parabolas. Rotates 360 degrees. Tilts 170 degrees. Noiseless controls.

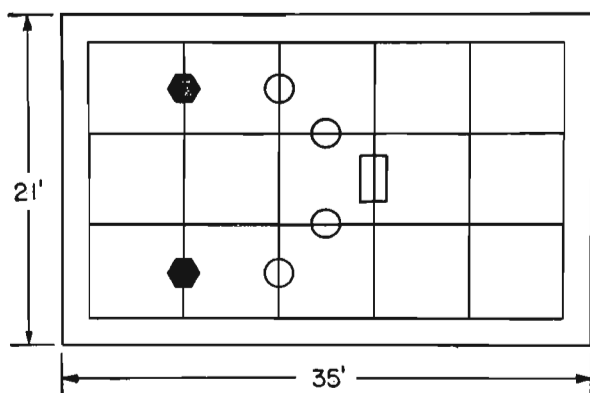
TYPICAL TV STUDIO-PROVED FLOOR PLANS AND CEILING ARRANGEMENT FOR RCA LIGHTING SYSTEMS



For a small interim-type studio, 21 feet x 35 feet. This plan more than meets the minimum lighting requirements of 200 foot candles and a contrast range of 2-to-1.

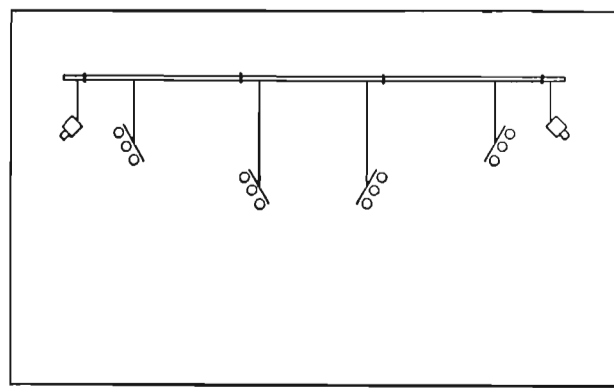

NO. REQD.	SYMBOL
1	HI-INTENSITY FLUORESCENT BANK 
4	INCANDESCENT FLOOD-LITES 
2	CONTROLLABLE SPOT-LITES 

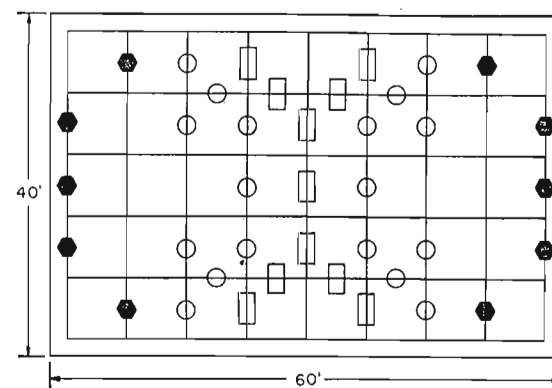

Cross-sectional view of a TV studio, showing RCA's inverted pyramid-type of lighting. This system delivers unobstructed light to every point in the studio.



For the average-size studio, 40 feet x 60 feet. This plan more than meets the minimum lighting requirements of 200 foot candles and a contrast range of 2-to-1.

NO. REQD.	SYMBOL
11	HI-INTENSITY FLUORESCENT BANKS 
18	INCANDESCENT FLOOD-LITES 
10	CONTROLLABLE SPOT-LITES 



TELEVISION BROADCAST EQUIPMENT
RADIO CORPORATION of AMERICA
ENGINEERING PRODUCTS DEPARTMENT, CAMDEN, N.J.

In Canada: RCA VICTOR Company Limited, Montreal

This new 5-kw FM Transmitter

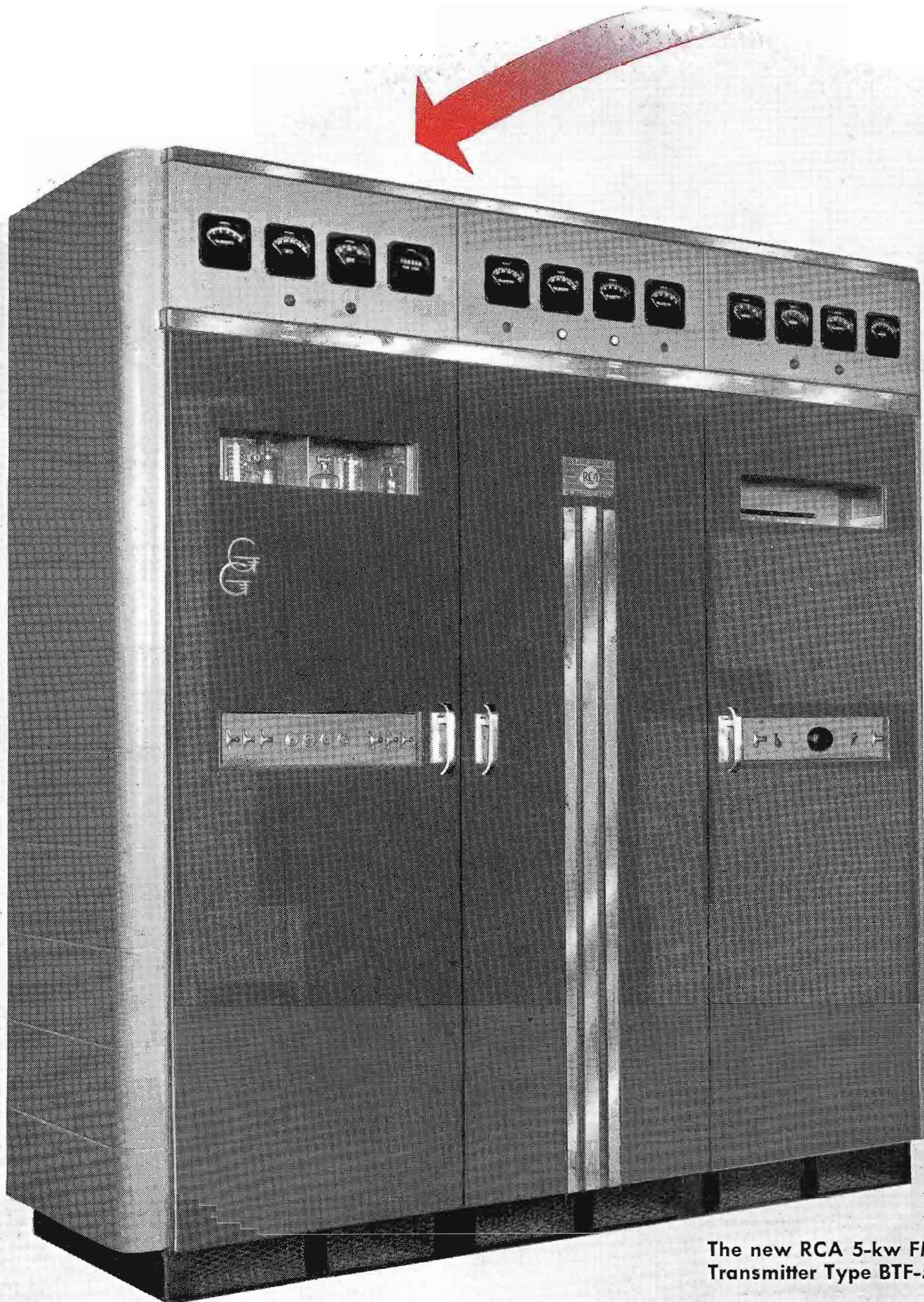

The new RCA 5-kw FM Broadcast Transmitter Type BTF-5A



BROADCAST EQUIPMENT
RADIO CORPORATION of AMERICA
ENGINEERING PRODUCTS DEPARTMENT, CAMDEN, N.J.

In Canada: RCA VICTOR Company Limited, Montreal

-and a 4-section Pylon

plus
gives you 20 kw ERP
... Economically

● For the broadcaster with an FM grant for 20 kilowatts, effective radiated power, this new transmitter . . . in combination with an RCA 4-section Pylon . . . *solves the problem economically.*

Here is the reason: a 4-section Pylon with a power gain of 6, steps-up the 5 kw to 30 kw (ERP) . . . allowing plenty of reserve power. This eliminates the costly choice of using either an expensive high-gain antenna structure with a low-power transmitter—or a higher power and more expensive transmitter with a conventional low-gain antenna.

Like all RCA's well-known FM transmitters, the BTF-5A uses RCA "Direct FM"—inherently capable of holding distortion and noise to extremely low levels. RCA power-saving Grounded-Grid circuits in the driver and final are designed to use the new RCA-5762 heavy-duty triodes. Both amplifiers require no neutralizing, are simple to tune, and are more stable than older and more conventional types. Type BTF-5A uses only 37 tubes and only 14 tube types. *Of these 37 tubes, only 21 tubes are required for emergency operation.*

All air-cooled, this transmitter includes every proved feature needed for efficient operation. It uses no trick circuits or gadgets—and it is simple to handle (inexperienced personnel can learn to run it in minutes). Unit construction makes the 5-kw FM transmitter easy to install. And if you now have an RCA 3-kw FM transmitter you can easily increase power to 5 kw by adding a simple conversion kit—now available.

For complete data on how this transmitter can radiate *from 20 to 60 kilowatts* of effective radiated power—and for information on the 5-kw conversion kit—see your RCA Broadcast Sales Engineer. Or write Dept. 19-DB, RCA Engineering Products, Camden, N. J.

Quick-Selection Chart for RCA Pylon Antennas
(Choose the type for power gain needed)

RCA 5-kw FM Transmitter	STANDARD PYLONS			Maximum Effective Radiated Power
	RCA Pylon Antenna			
	Type	Gain	No. Sections	
BTF-5A	BF-11 A/B	1.5	1	7.5 kw
BTF-5A	BF-12 A/B	3	2	15 kw
BTF-5A	BF-14 A/B	6	4	30 kw
BTF-5A	BF-18 A/B	12	8	60 kw
HEAVY-DUTY PYLONS				
BTF-5A	BF-12 E/F	3	2	15 kw
BTF-5A	BF-14 C/D	6	4	30 kw

RCA 4-section Pylon delivers up to 30 kw (E. R. P.) with the BTF-5A transmitter!

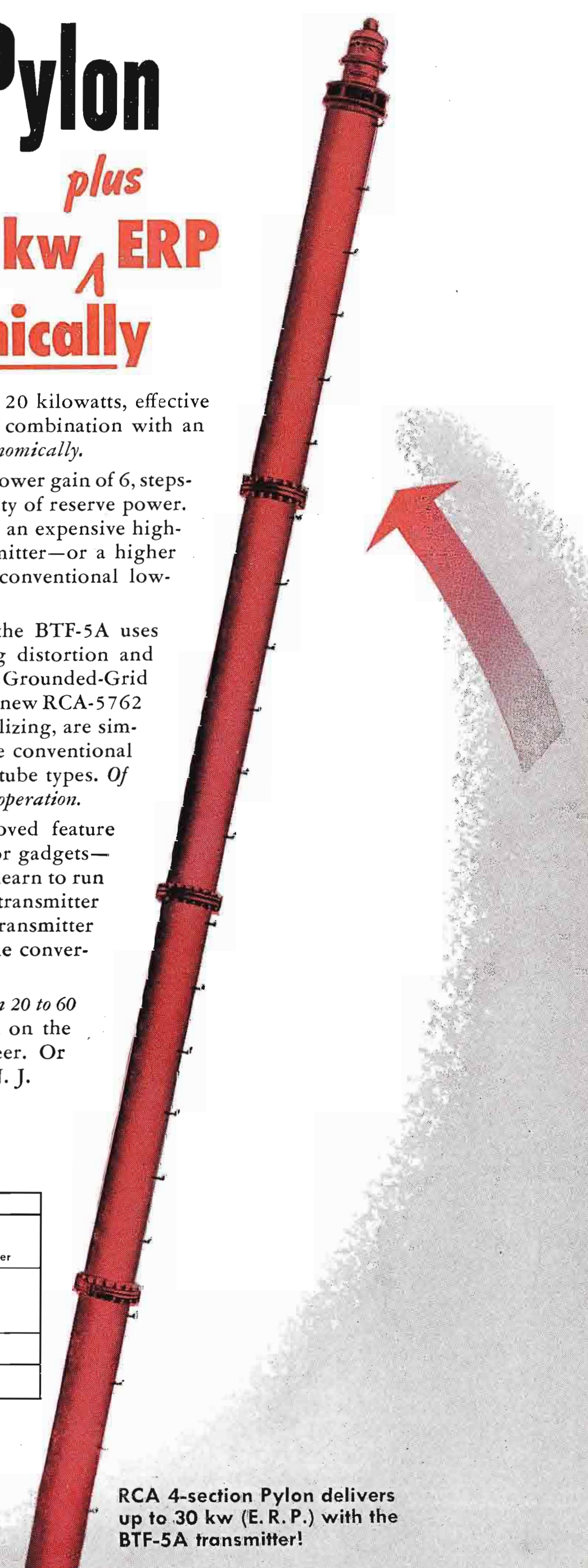



THE RCA ELECTRON MICROSCOPE, of which the console model is shown above, has made it possible to observe particles as small as one one-millionth of an inch in diameter. Its tremendous magnification—as much as 200,000 times—is achieved by the use of electron optics. The principles of electron optics are also of utmost importance in the development of television tubes. Thus, research in television and research in electron microscopy go hand in hand. In addition to the console model shown above, RCA makes and sells a large-size deluxe model of the electron microscope, an electron diffraction camera, a time interval counter, a vacuum gauge, and other electronic and nucleonic equipments which have many applications in science and industry.